

Light Commercial & Commercial, Residential CONTROL SYSTEM & OPTIONAL PARTS

- C-002 Control System Overview
- C-006 Best Control Solution for Each Building Structure
- C-008 Comparison Table of Controllers
- C-048 Control System List
- C-056 Optional Parts Overview
- C-062 Optional Parts List
- C-066 Function List

A wide product lineup to meet a variety of needs

We can flexibly meet customer needs through a variety of offerings including wired and wireless individual remote controllers, central remote controllers that simultaneously control multiple indoor units, and a variety of converters that link with other systems.

CONTROL SYSTEM

INDIVIDUAL CONTROL

- C-010 Wired Remote Controller (with touch panel)
- C-012 Wired Remote Controller / Compact Wired Remote Controller
- C-013 Wired Remote Controller
- C-014 Simple Remote Controller
- C-015 Wireless Remote Controller
- C-016 IR Receiver Unit

CONVERTERS/ADAPTERS

- C-018 WLAN Adapter
- C-022 Multi-split Protocol WLAN Adapter

CENTRALIZED CONTROL



- C-023 Home Central Remote Controller
- C-024 Central Remote Controller
- C-026 Touch Panel Controller
- C-030 System Controller Software / System controller Lite Software

CONVERTERS/ADAPTERS

- C-034 MODBUS® Converter for Indoor unit
- C-035 MODBUS® Interface
- C-036 MODBUS® Converter for VRF
- C-037 BACnet® interface
- C-038 BACnet® Gateway Software
- C-039 BACnet® Gateway Hardware
- C-040 BACnet®/MODBUS® Router
- C-041 BACnet®/MODBUS® Cloud Device
- C-042 KNX® converter for Indoor unit / KNX® converter for VRF
- C-043 KNX® Interface
- C-044 Network Converter for Single-Split Type
- C-045 Network Converter for LONWORKS™
- C-046 External switch controller / Signal Amplifier

Optional parts

- C-058 Silver Ion Filter
- C-059 Auto Louver Grille Kit
- C-060 Pressure Sensor Kit
- C-061 External Power Supply Unit
AIR BEAM Radiation air outlet unit
- C-070 Separation Tube and other piping products

-  SPLIT
-  MULTI-SPLIT
-  VRF J Series
-  VRF V Series

Control System Overview

for Split & Multi-split

All indoor units* are equipped with a wireless or wired remote controller as standard. Additional options are available, such as individual remote controllers and central remote controllers. The easy-to-operate central remote controller makes it simple to control the operation mode, temperature, airflow volume, timer, and other functions of each indoor unit from a single location.

* Except for some products



Air Conditioning Individual control



Wired remote controller
A built-in thermo sensor monitors and controls room temperature accurately.



Wireless remote controller
Simple and versatile operations with a choice of 4 different types of timers



Simple remote controller
Compact remote controller with basic functionality

For Ceiling type

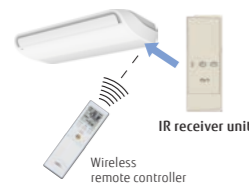

For Duct type

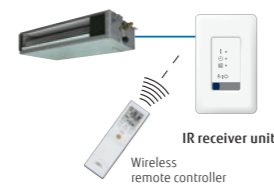

For Cassette type



IR receiver unit
This IR receiver unit enables a wireless remote controller to control a duct-type indoor unit.

Air Conditioning Centralized control



Home central remote controller for 5 & 6-unit Multi-split type
Enables individual and central control.

Converters/Adapters

For external control via BMS/Home Automation Systems

MODBUS® converter for indoor units
UTY-VMSX



MODBUS® interface for indoor units



KNX® converter for indoor units
UTY-VK SX



KNX® interface for indoor units



WLAN adapter



Network converter

DC power supply type
UTY-VTGX



AC power supply type
UTY-VTGXV



Online Control (Wireless Control via Smartphone/Tablet)

With the WLAN adapter and the AIRSTAGE Mobile app, you can control the heating and cooling of your home anytime, anywhere.

WLAN adapter

The dedicated WLAN adapter enables the air conditioner to be operated by smartphone or tablet computer.



Simple, user-friendly interface design

The designed screen display makes it easier than ever to operate.

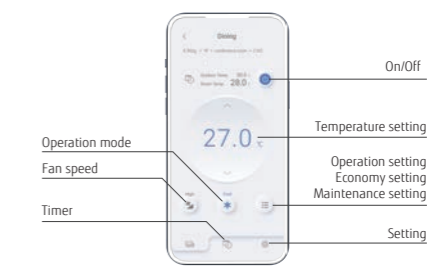

Control System Overview

for VRF

To meet the diverse needs of customers, we offer a variety of control options for our VRF systems, such as individual control, centralized control, and building management system (BMS) options.

Air Conditioning Individual control



Wired remote controller (with touch pane)
UTY-RNRYZ5



Wired remote controller
UTY-RLRY



Compact wired remote controller
UTY-RCRYZ1



Simple remote controller
UTY-RSRY
UTY-RHRY
Without operation mode



Wireless Remote Controller
UTY-LNHY



For Duct type
For One-way flow cassette Series/3D-flow cassette Series/duct type

IR receiver unit

UTB-YWC for duct type
UTY-TRHX for One-way flow cassette Series/3D flow cassette Series/duct type



for Circular flow cassette Series

UTY-LBHXD for Circular flow cassette Series

Air Conditioning Centralized control

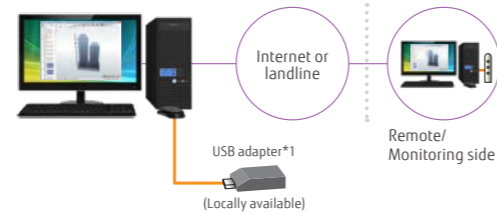

System controller (Software)
UTY-APGXZ1/UTY-ALGXZ1 (Lite version)
Up to 1600^{*2} Indoor units

*1: Echelon® U10 USB Network Interface
*2: The Lite version controls up to 400 indoor units.

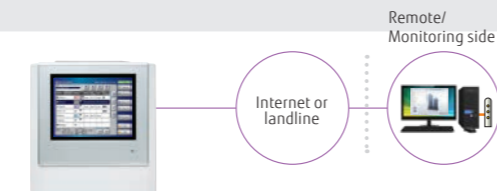

Touch panel controller
UTY-DTGYZ1
Up to 400 Indoor units



Central remote controller
UTY-DCGYZ2
Up to 100 Indoor units

Converters/Adapters

For external control via BMS/Home Automation Systems

BACnet® gateway
UTY-ABGXZ1 **(Software)**



VTY-VBGX (Hardware)



BACnet® interface for Indoor units
FG-IR-BMG1Z1



Network converter (For LonWORKS™)
UTY-VLGX



MODBUS® converter for Indoor units
UTY-VMSX



for VRF
UTY-VMGX



KNX® converter for Indoor units
UTY-VKSX



for VRF
UTY-VKGX



WLAN adapter
UTY-TFSXJ3 / UTY-TFSXZ1



External switch controller
UTY-TERX



BMS/BAS^{*3}



BMS^{*3}, Home automation system



*3: BMS/BAS: Building Management System/Building Automation System

Converters/Adapters for system expansion

Network converter DC power supply type
UTY-VTGX



Network converter AC power supply type
UTY-VTGXV



Signal amplifier
UTY-VSGXZ1



Card-key (Locally available)

Internet device

Best control solution for each building structure

Fujitsu General provides the best control solutions suitable for various building structures.

SHOP

Type	Individual control			Centralized control			Integrating control (Interface)				
	Wired remote controller	Simple remote controller	Wireless remote controller	Central remote controller	Touch panel controller	System controller	Network converter for LONWORKS™	MODBUS® Converter	KNX® converter	External switch controller	
	UTY-RNRYZ5 UTY-RLRY UTY-RVNYM UTY-RCRYZ1	UTY-RSRY UTY-RHRY UTY-RSNYM	UTY-LNHY UTY-LNTY	UTY-DCGYZ2	UTY-DTGYZ1	UTY-APGXZ1 UTY-ALGXZ1	UTY-ABGXZ1 UTY-VBGX	UTY-VLGX	UTY-VMGX	UTY-VKGX	UTY-TERX
Automatic control of air conditioning (Schedule timer, Weekly timer, etc.)	•			•	•	•					
Controls limited to staff: Remote controller prohibition, Setting temperature range limitation, etc.				•	•	•		•	•		•
Group control				•	•	•					
Advanced energy saving: Peak cut, Operation of indoor unit rotation, etc.						•					
Remote monitoring management				•	•	•					
Manage multiple sites				•	•	•					
Monitor energy consumption						•					
Control third-party products						•					
Integrate Fujitsu General air conditioning into BMS							•	•	•		















HOTEL

Type	Individual control			Centralized control			Integrating control (Interface)				
	Wired remote controller	Simple remote controller	Wireless remote controller	Central remote controller	Touch panel controller	System controller	BACnet® gateway	Network converter for LONWORKS™	MODBUS® converter	KNX® converter	External switch controller
	UTY-RNRYZ5 UTY-RLRY UTY-RCRYZ1	UTY-RSRY UTY-RHRY UTY-RSNYM	UTY-LNHY UTY-LNTY	UTY-DCGYZ2	UTY-DTGYZ1	UTY-APGXZ1 UTY-ALGXZ1	UTY-ABGXZ1 UTY-VBGX	UTY-VLGX	UTY-VMGX	UTY-VKGX	UTY-TERX
Local control for hotel guests	•	•	•								
Centralized air conditioning control for common areas				•	•	•	•	•	•	•	
Limited control for hotel guests				•	•	•	•	•	•	•	
Remote monitoring management				•	•	•					
Advanced energy saving: Peak cut, Operation of indoor unit rotation, etc.						•	•				
Monitor energy consumption						•					
Control third-party products						•					
Integrate Fujitsu General air conditioning into BMS							•	•	•	•	
Interlock with window contact											•
Interlock with key card											•

OFFICE

Type	Individual control			Centralized control			Integrating control (Interface)				
	Wired remote controller	Simple remote controller	Wireless remote controller	Central remote controller	Touch panel controller	System controller	BACnet® gateway	Network converter for LONWORKS™	MODBUS® converter	KNX® converter	External switch controller
	UTY-RNRYZ5 UTY-RLRY UTY-RCRYZ1	UTY-RSRY UTY-RHRY UTY-RSNYM	UTY-LNHY UTY-LNTY	UTY-DCGYZ2	UTY-DTGYZ1	UTY-APGXZ1 UTY-ALGXZ1	UTY-ABGXZ1 UTY-VBGX	UTY-VLGX	UTY-VMGX	UTY-VKGX	UTY-TERX
Local control for office staff	•	•	•	•							
Automatic control of air conditioning (Schedule timer, Weekly timer, etc.)	•		•	•	•	•	•				
Centralized air conditioning control for management				•	•	•	•	•	•	•	
Controls limited to staff: Remote controller prohibition, Setting temperature range limitation, etc.				•	•	•	•	•	•	•	
Advanced energy saving: Peak cut, Operation of indoor unit rotation, etc.						•	•				
Remote monitoring management				•	•	•					
Electricity charge apportionment					•	•	•				
Monitor energy consumption						•					
Control third-party products						•					
Integrate Fujitsu General air conditioning into BMS							•	•	•	•	
Interlock with door contact											•
Interlock with Occupancy sensor for meeting room				•							•

Comparison table of controllers

Item																
	Wired remote controller (with touch panel)	Wired remote controller	Wired remote controller	Compact wired remote controller	Simple remote controller	Simple Remote Controller		Simple remote controller*1	Wireless remote controller	Wireless remote controller	Home central remote controller (for 5/6-unit multi-split type)	Central remote controller	Touch panel controller	System controller Lite (Software)	System controller (Software)	
Model name	UTY-RNRYZ5	UTY-RLRY	UTY-RVNYM	UTY-RCRYZ1	UTY-RSNYM	UTY-RSRY		UTY-RHRY	UTY-LNHY	UTY-LNTY	UTY-DMMYM	UTY-DCGYZ2	UTY-DTGVZ1	UTY-ALGXZ1	UTY-APGXZ1	
Maximum number of controllable remote controller groups	1	1	1	1	1	1		1	1	1	1	100	400	400	1600	
Maximum number of controllable indoor units	16	16	16	1	16	16		16	16	16	8	100	400	400	1600	
Maximum number of controllable groups	-	-	-	-	-	-		-	-	-	-	50	400	400	1600	
Air conditioning control functions	ON/OFF	●	●	●	●	●		●	●	●	●	●	●	●	●	
	Operation mode setting	●	●	●	●	●		-	●	●	●	●	●	●	●	
	Fan speed control	●	●	●	●	●		●	●	●	●	●	●	●	●	
	Room temperature setting	●	●	●	●	●		●	●	●	●	●	●	●	●	
	Setting temperature range limitation	●	●	●	-	-		●	-	-	-	●	●	●	●	
	Test operation	●	●	●	●	●		●	●	●	-	-	●	-	-	
	Vertical louver setting	●	●	●	●	-		●	●	●	-	●	●	●	●	
	Horizontal louver setting	●	●	●	●	-		-	●	-	-	●	●	●	●	
	Individual louver control	●	-	-	●	-		-	-	-	-	-	● ^{*3}	-	-	
	Group setting	-	-	-	-	-		-	-	-	-	●	●	●	●	
	Remote controller prohibition	-	-	-	-	-		-	-	-	-	●	●	●	●	
	Anti-freeze setting	●	-	-	●	-		-	-	-	-	●	●	●	●	
	Set temperature auto return	●	●	●	-	-		-	-	-	-	-	●	-	-	
	Economy mode setting	●	●	●	●	-		-	●	●	●	●	●	●	●	
	Occupancy sensor control	●	-	-	-	-		-	-	-	-	●	●	●	●	
Displayed items	Error	●	●	●	●	●		●	-	-	●	●	●	●	●	
	Defrosting	●	●	●	●	●		●	-	-	-	●	●	●	●	
	Current time	●	●	●	-	-		-	●	●	●	●	●	●	●	
	Day of week	●	●	●	-	-		-	-	-	-	●	●	●	●	
	Remote controller prohibition	●	●	●	●	●		●	-	-	●	●	●	●	●	
	Address display	●	●	●	●	●		●	-	-	-	-	●	●	●	
	Room temperature	●	-	●	●	-		●	-	-	-	● ^{*4}	● ^{*4}	● ^{*4}	● ^{*4}	
	Multiple language support	●	-	●	-	-		-	-	-	●	●	●	●	●	
	Setting for daylight saving time	●	-	●	-	-		-	-	-	●	●	●	●	●	
	Name registration	●	-	-	-	-		-	-	-	-	●	●	●	●	
	Backlighting	●	-	●	●	●		●	-	-	●	●	●	-	-	
	2D floor layout/3D building display	-	-	-	-	-		-	-	-	-	-	-	-	●	
	Refrigerant leak detector	-	-	-	-	-		-	-	-	-	●	●	●	●	
	Timer	Schedule timer	Period	Week	Week	Week	-		-	-	-	Week	Week	Year	Year	Year
			ON/OFF, Temp, Mode, Times per day	8	4	8	-		-	-	-	4	20	20	144	144
ON/OFF timer		●	●	●	●(OFF only)	-		-	●	●	-	-	-	-	-	
Sleep timer		-	-	-	-	-		-	●	●	-	-	-	-	-	
Program timer		-	-	-	-	-		-	●	●	-	-	-	-	-	
Auto-off timer		●	●	●	-	-		-	-	-	-	●	●	-	-	
Control	Day off	●	●	●	-	-		-	-	-	●	●	●	●	●	
	Minimum unit of timer setting (minutes)	10 • 30	30	30	-	-		-	5	5	5	10	10	10	10	
	Remote monitoring management system	-	-	-	-	-		-	-	-	-	●	●	●	●	
	Electricity charge apportionment	-	-	-	-	-		-	-	-	-	-	○	○	●	
	Error history	●	●	●	-	-		-	-	-	-	●	●	●	●	
	Emergency stop	-	-	-	-	-		-	-	-	-	● ^{*2}	● ^{*2}	-	-	
	Remote monitoring management	-	-	-	-	-		-	-	-	-	●	●	○	●	
	Energy-saving management	-	-	-	-	-		-	-	-	-	-	-	○	○	
	E-mail notification in case of failure	-	-	-	-	-		-	-	-	-	●	●	●	●	
	Key lock	● Child lock	● Child lock	● Child lock	-	-		-	-	-	-	● Child lock	● Password setting	● Password setting	● Password setting	● Password setting
Low noise mode	-	-	-	-	-		-	-	-	-	●	●	●	●		

*1 "Operation mode" setting not available.
 *2 Available only for external input control.
 *3 Monitoring sites can be set up.
 The main unit side can only be operated to cancel the settings.
 *4 Available only when using Wired remote controller.
 ●: Supported ○: Optional function -: Unsupported

Wired remote controller (with touch panel)

UTY-RNRYZ5



Up to **16** indoor units
Up to **1** group

Easy operation due to large high-resolution STN-LCD touch panel screen

- Touch screen LCD
- Built-in daily/weekly timer (ON/OFF, temperature, modes)
- Backlit screen for easy operation in the dark.
- Room temperature display
- Controls up to 16 indoor units
- Supports 12 languages: Chinese, Dutch, English, French, German, Greek, Italian, Polish, Portuguese, Russian, Spanish, and Turkish
- Nonpolar 2-core type

High performance and compact size

A single remote controller controls each connected indoor unit and provides a weekly timer function and a variety of energy-saving options.



Accurate control for comfort

A thermo sensor built into the remote controller monitors room temperature accurately.

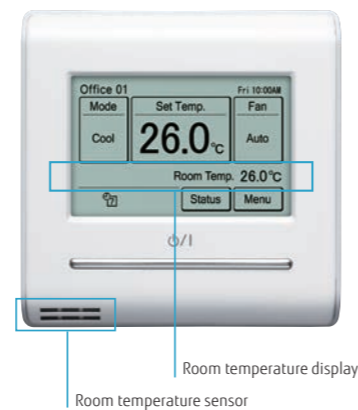

Energy saving controls

Custom Auto

- Maintains 2 separate setpoints for heating and cooling operations.
- Automatically switches between heating and cooling modes.

* Not available for some models

Auto-off timer

- While the Auto-off timer is activated, if the set off time is specified as, for example, one hour, the power will automatically turn off one hour after the start of operation.
- A desired time frame can be specified for the Auto-off timer.
- The off-time can be set from 30 to 240 minutes.

2-setting weekly timer

Set temperature auto return

Setting temperature range limitation

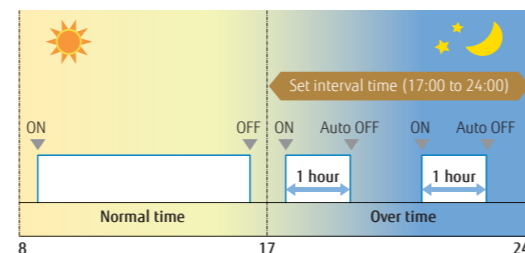
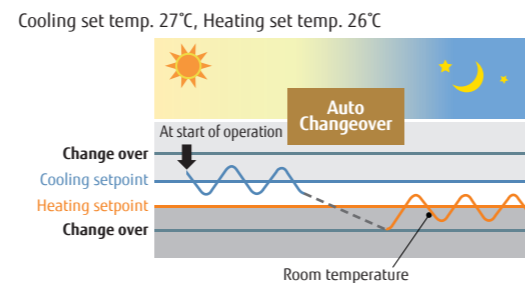

e.g.) Between 17:00 and 24:00 (over time hours), when the 1 hour set off time has elapsed, the system will automatically turn off the indoor unit as it

Features: Wired Remote Controller (Touch Panel)

Refrigerant cycle monitor (Option)

Wired Remote Controller (Touch Panel) will support to display some sensor values for maintenance and service support.

* This function is only supported by split units, using the H-Serial communication protocol! Example: ASYH30KMTB

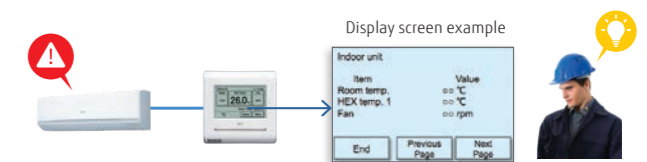

Multi System Control*1

1) Lead Lag Operation

Standby Indoor Unit can be selected in lead lag operation. By this, the Indoor units will last longer than operating by nonstop.

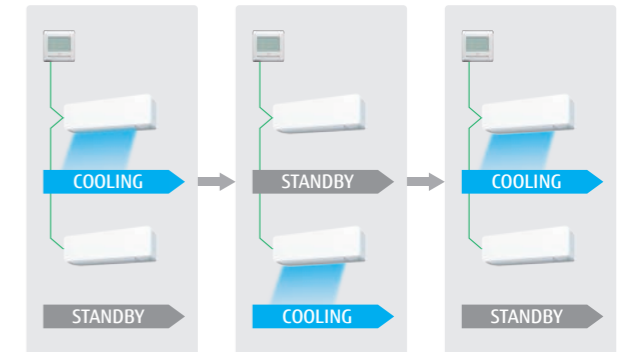

2) Back up operation

In case of unexpected Indoor unit error, other Indoor units will start providing back up operation.

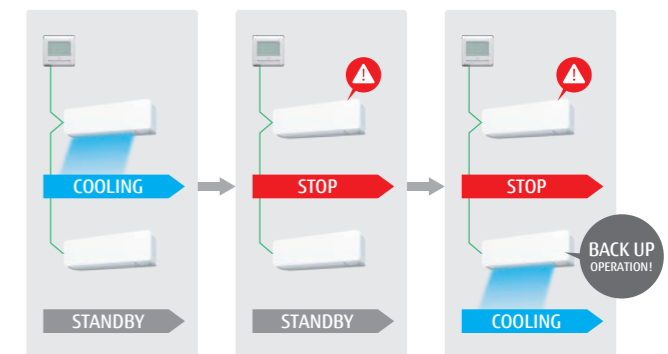

3) Lag Operation

In case of unexpected room temperature rise, other Indoor Units will start providing lag operation.

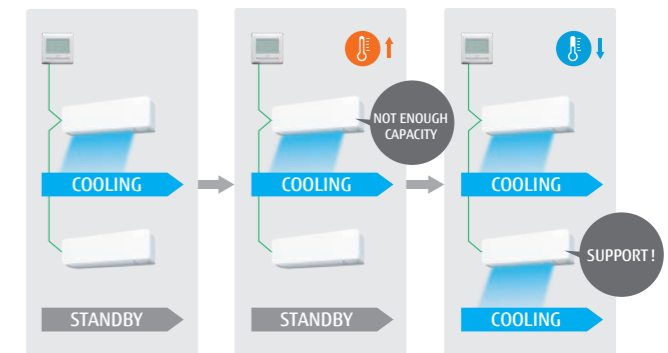

*1: "Lead Lag Setting" is an easy-to-use function for room temperature control when using multiple indoor units, while reducing the burden placed on each indoor unit.

If you wish to make use of this function, ensure you use indoor units equipped with a "Special Cooling" function.

For Split products with "Special Cooling" function, refer to S-054 to S-057.

If you use indoor units that do not have a "Special Cooling" function, under certain conditions, there is a chance that "Backup operation" may not operate correctly, and the "Lead Lag Setting" function will not give the expected results.

Additionally, for rooms that require strict conditions, such as server rooms, please consider other appropriate measures.

Please note that we will not provide compensation for any damages suffered to your appliances or data as a result of using this function. For more details, please confirm with your nearest retail store.

Specifications

Model name	UTY-RNRYZ5
Power Source	DC 12 V
Dimensions (H × W × D) (mm)	120 × 120 × 20.4
Weight (g)	220

DC 12 V is supplied by the indoor unit.

Wired remote controller

UTY-RLRY



- ON/OFF/Weekly timer settings
- A built-in thermo sensor monitors and controls room temperature accurately.
- When something goes wrong, an error code is displayed.
- 16 error codes from the most recent one will be kept in the history. (Last 16 error codes can be accessed)
- Nonpolar 2-core type

Up to
16 indoor units
Up to
1 group

High performance and compact size

A single remote controller controls each connected indoor unit and provides a weekly timer function and a variety of energy-saving options.



Visually intuitive operation

- The operation mode, set temperature, and fan speed are shown prominently on the top screen.
- Each function to be set is indicated by an icon.
- The control guide makes it simple and straightforward to operate a remote controller.

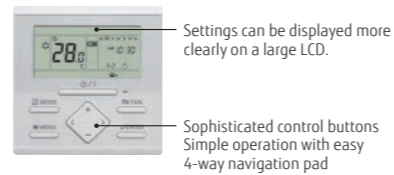

Compact wired remote controller

UTY-RCRYZ1

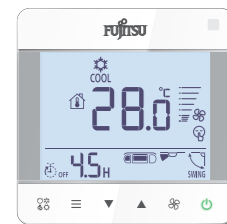

- Simple design that matches stylish interiors
- The body of the controller, which is easy to install, is designed to conform to the European standard junction box.
- Can be operated both by wireless and wired remote controller.
- Nonpolar 2-core type

Up to
1 indoor units
Up to
1 group

Large screen and simple display

- Large screen but compact size
- Large, easy-to-read letters are used.
- The controls are simple and easy to understand.

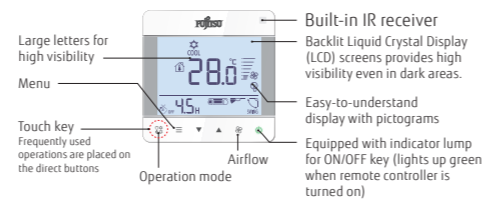

System overview

VRF connection

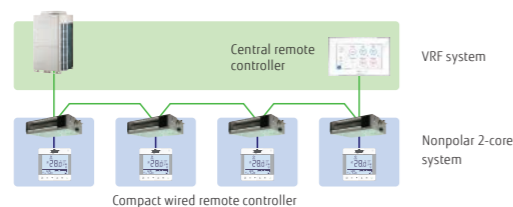

RAC connection

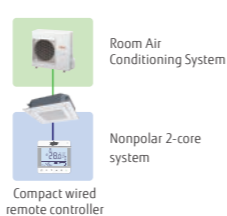

Specifications

Model name	UTY-RLRY	UTY-RCRYZ1
Power source	12 V DC	12 V DC
Dimensions (H × W × D) (mm)	120 × 120 × 17	86 × 86 × 44
Weight (g)	170	135

12 V DC supplied by an indoor unit

Wired remote controller

UTY-RVNYM



Up to
16 indoor units
Up to
1 group

Hi-grade individual control with a wide range of functions.

- 3.7-inch backlit LCD screen.
- Supports energy-saving functions with simple operation.
- Supports 9 languages: English, French, German, Greek, Italian, Portuguese, Russian, Spanish, and Turkish

Visually intuitive operation

- Each function is displayed as an icon.
- Main functions are indicated by large icons: "Mode," "Set Temp," and "Fan"
- Easy operation with control guide display
- Simple operation with easy 4-way navigation pad

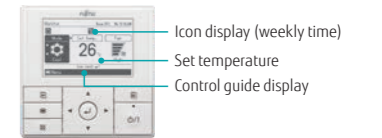

High performance and compact size

- A single remote controller controls each connected indoor unit and provides a variety of energy-saving options.



Wired remote controller

UTY-RNNYM



Up to
16 indoor units
Up to
1 group

- Simple operation with Built-in Weekly/Daily Timer.
- Control up to 16 indoor units.
- Up to 2 Wired remote controllers can be connected to a single indoor unit.

Accurate control for comfort

A thermo sensor built into the remote controller monitors room temperature accurately. The wired remote controller and an optional Remote sensor can be installed in any location to meet any requirement.

Examples of sensor changes

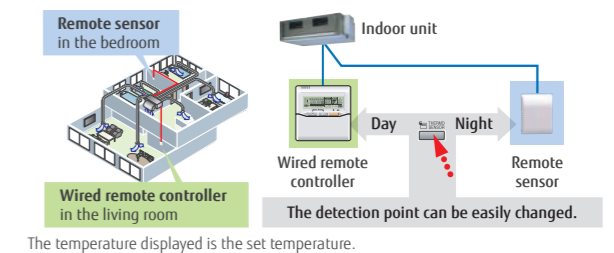

The temperature displayed is the set temperature.

Built-in timer

- **Weekly timer:** ON/OFF time can be set to operate twice for each day of the week.
- **Temperature setback timer:** Sets the time to change the temperature setting and the time to hold the setting for each day of the week.
- At "Weekly timer" + "Temperature setback timer" setup

Specifications

Model name	UTY-RVNYM	UTY-RNNYM
Power source	12 V DC	12 V DC
Dimensions (H × W × D) (mm)	120 × 120 × 21.3	120 × 120 × 18
Weight (g)	220	160

12 V DC supplied by an indoor unit

Simple remote controller

UTY-RSRY / UTY-RHRY (without operation mode)

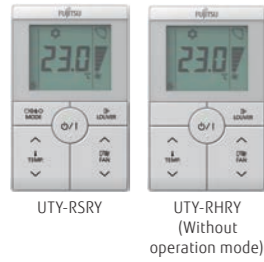

Compact remote controller with basic functionality

- Up to 16 indoor units can be controlled with one remote controller.
- Suitable for hotels or offices as it is easily operated with no complex functions.
- Simple design that matches stylish interiors
- Large LCD screen and easy-to-use control buttons
- Backlight: White backlight makes it easy to operate in the dark.
- Nonpolar 2-core type

Up to
16 indoor units
Up to
1 group

Supports a variety of applications

- **Vertical louver control:** Adjusts the vertical airflow direction of a duct-type indoor unit with an auto louver or a cassette type installed in a hotel room or a conference room.
- **Setting temperature range limitation:** Enables an indoor unit to operate in an energy-saving manner in a small building not equipped with a central remote controller.
- **Built-in room temperature sensor:** Monitors and controls room temperature accuracy.

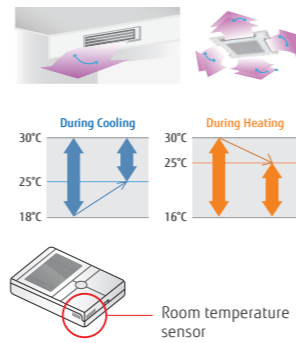

Simple remote controller

UTY-RSNYM



Compact remote controller with basic functionality

- Up to 16 indoor units can be controlled with one remote controller.
- Suitable for hotels or offices as it is easily operated with no complex functions.
- Backlit screen for easy operation in the dark.
- Polar 3-core type

Up to
16 indoor units
Up to
1 group

Easy-to-use operation

- Enables basic control of an indoor unit, such as ON/OFF, fan speed, operation mode select, and room temperature setting.
- A large ON/OFF button is located in the middle for quick access.
- Works with other individual control units.
- When something goes wrong, an error indicator will appear, and diagnostics can be performed with the remote controller.

Specifications

Model name	UTY-RSRY	UTY-RHRY	UTY-RSNYM
Power source	12 V DC	12 V DC	12 V DC
Dimensions (H × W × D) (mm)	120 × 75 × 19.4	120 × 75 × 19.4	120 × 75 × 19.4
Weight (g)	120	120	120

12 V DC supplied by an indoor unit

Wireless remote controller

UTY-LNTY



Simple and versatile operations with a choice of 4 different types of timers

- Controls up to 16 indoor units.

Built-in timer

4 timer programs: ON/OFF/Program/Sleep
 Program timer: Sets ON/OFF time once for every 24 hours.
 Sleep timer: Adjusts the set temperature automatically while the sleep timer is on.

Up to
16 indoor units
Up to
1 group
Up to
4 different daily timers

Easy installation and operation

Different codes can be assigned to up to 4 indoor units to prevent a mix-up.
 Wide and precise transmitting range

Wireless remote controller

UTY-LNHY



Simple and versatile operations with a choice of 4 different types of timers

- Controls up to 16 indoor units.

Built-in timer

4 timer programs: ON/OFF/Program/Sleep
 Program timer: Sets ON/OFF time once for every 24 hours.
 Sleep timer: Adjusts the set temperature automatically while the sleep timer is on.

Up to
16 indoor units
Up to
1 group
Up to
4 different daily timers

Easy installation and operation

Different codes can be assigned to up to 4 indoor units to prevent a mix-up.
 Wide and precise transmitting range

Specifications

Model name	UTY-LNTY	UTY-LNHY
Battery	1.5 V (R03/LR03/AAA)	1.5 V (R03/LR03/AAA)
Dimensions (H × W × D) (mm)	205 × 61 × 17	170 × 56 × 19
Weight (g)	125	85

12 V DC supplied by an indoor unit

IR receiver unit for duct type

UTY-LRHYM / UTY-LBTYM

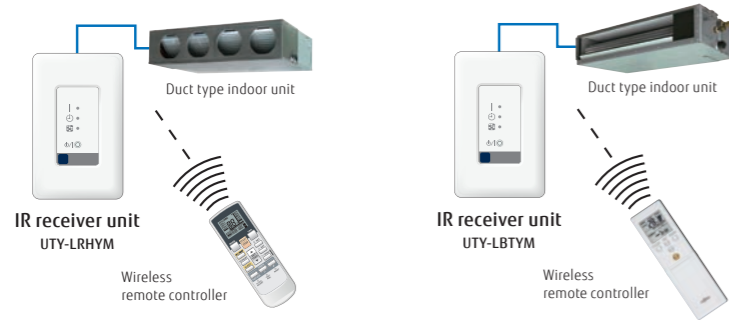

The wireless remote controller controls duct type indoor units.

IR receiver unit for Cassette

UTY-LBTYC



Cassette type indoor unit can be controlled with a Wireless remote controller.

IR receiver unit for ceiling type

UTY-LBTYH



The wireless remote controller controls ceiling type indoor units.

Specifications

< Wireless Remote Controller >

Model name	UTY-LRHYM	UTY-LBTYM	UTY-LBTYC	UTY-LBTYH
Battery	1.5 V (R03/LR03/AAA)	1.5 V (R03/LR03/AAA)	1.5 V (R03/LR03/AAA)	1.5 V (R03/LR03/AAA)
Dimensions (H × W × D) (mm)	170 × 56 × 19	205 × 61 × 17	205 × 61 × 17	205 × 61 × 17
Weight (g)	85	125	125	125

< IR Receiver Unit >

Battery	DC5V	DC5V	DC5V	DC5V
Dimensions (H × W × D) (mm)	145 × 90 × 30	145 × 90 × 30	-*	-*
Weight (g)	150	150	140	100

DC 5 V is supplied the indoor unit.

*It will replace the parts of the indoor unit to be connected.

IR receiver unit for duct type

UTB-YWC / UTY-TRHX



The wireless remote controller controls duct type* indoor units.

*Large airflow duct types do not work with this IR receiver unit.



*A separate wireless remote control (model: UTY-LNHY) is required.

IR receiver unit for Cassette

UTY-LBHXD / UTY-TRHX



Cassette type indoor unit can be controlled with a Wireless remote controller.

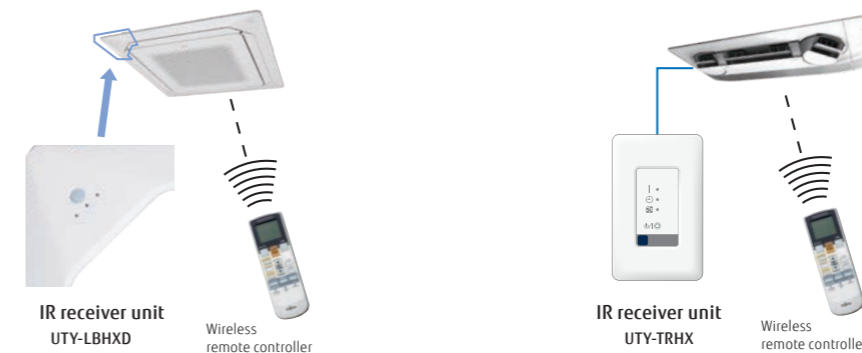

*A separate wireless remote control (model: UTY-LNHY) is required.

Specifications

< Wireless Remote Controller >

Model name	UTB-YWC	UTY-LBHXD	UTY-TRHX
Battery	1.5 V (R03/LR03/AAA)	1.5 V (R03/LR03/AAA)	1.5 V (R03/LR03/AAA)
Dimensions (H × W × D) (mm)	170 × 56 × 19	170 × 56 × 19	170 × 56 × 19
Weight (g)	85	85	85

< IR Receiver Unit >

Battery	DC5V	DC5V	DC5V
Dimensions (H × W × D) (mm)	145 × 90 × 30	-*	145 × 90 × 30
Weight (g)	150	140	150

DC 5 V is supplied the indoor unit.

*It will replace the parts of the indoor unit to be connected.

WLAN adapter

UTY-TFSXH3 / UTY-TFSXJ3



NEW



USB type for single split models
UTY-TFSXH3

“AIRSTAGE Mobile” is an application software that enables you to manage the Fujitsu General’s air conditioner(s) with a mobile device from anywhere.

- Maximum 5 accounts per 1 indoor unit
- Room / Outdoor temperature display
- Can be used for a Single / Multi and VRF indoor units.
- No separate external power supply required



UTY-TFSXJ3
(CN connector type)

Up to
1 indoor units

User Friendly for Everyone

Enjoy easy-to-use centralized operation of air conditioners via a smartphone anytime, anywhere



Image*



House Owner



Shop Owner



Commercial Building Owner

Main Functions

- ON / OFF
- Operation mode
- Fan speed
- Louver position
- Set temperature control
- Weekly timer
- Room temperature display
- Outdoor temperature display
- Error display



*Contents of display differ depending on the type of indoor unit.

New Design!

Ease of use is pursued to achieve a stylish design.

The more legible and accessible timer UI enables effortless schedule management.

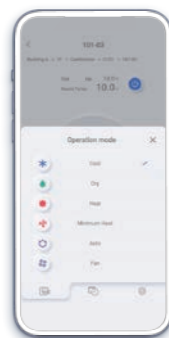

Mode change



Fan speed change

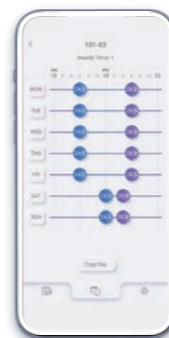

Weekly timer



Features: AIRSTAGE Mobile

Centralized operation for flexible remote management of all air conditioners

AIRSTAGE Mobile is ideal for a wide range of applications, from large residential buildings to smaller commercial spaces such as offices and stores. Anyone who has a smartphone and an adapter can easily manage the system at a low cost.

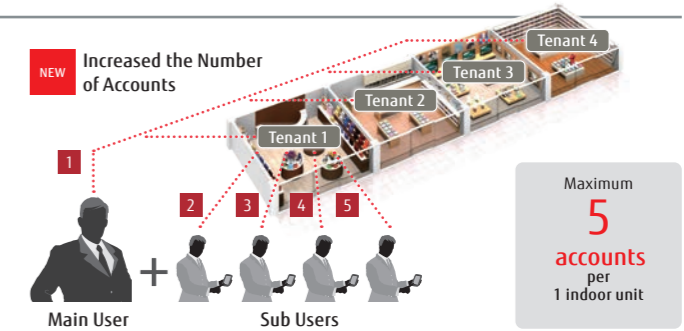

Hierarchical group management

Multiple air conditioners can be combined into a single group for centralized operation. Several groups can also be organized at once. Grouping the air conditioners by building, floor, or room makes it easy for users to monitor their operation status and operate them quickly.



Operate air conditioner and check its operation status just by talking to it

Connecting with a smart speaker allows the user to operate the air conditioner and check its operation status just by talking to it.

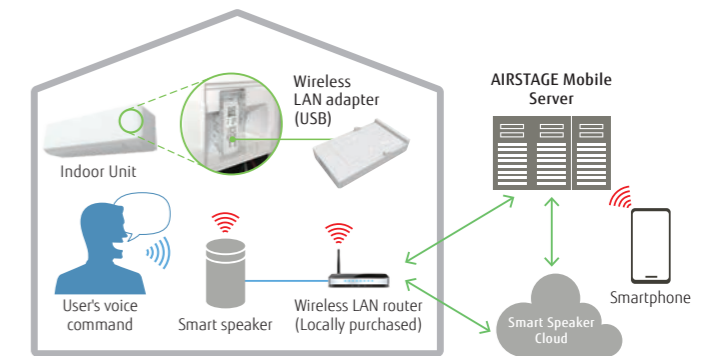

* The new WLAN adapters for AIRSTAGE Mobile are upper compatible for the indoor units that can connect the following WLAN adapters for FGLair.

	CN connector type	USB type
for FGLair	UTY-TFSXZ1	UTY-TFSXF2
for AIRSTAGE Mobile	UTY-TFSXJ3	UTY-TFSXH3

Specifications

Model name	UTY-TFSXJ3(CN connector type)	UTY-TFSXH3
Dimensions (H × W × D) (mm)	71 × 38 × 15	56.7 × 34 × 9.72
Weight (g)	35	30

WLAN adapter

UTY-TFNXZ1 / UTY-TFSXZ1 / UTY-TFSXF2



USB type for single-split models
UTY-TFSXF2



UTY-TFNXZ1
(3-wire RC-line type)
UTY-TFSXZ1
(CN connector type)

Up to
1 indoor units



- This interface provides the most advanced solution for the remote management of an air conditioning system by using smartphones, tablets, and computers.
- No separate external power supply required
- Can be used for a Single / Multi and VRF indoor units.

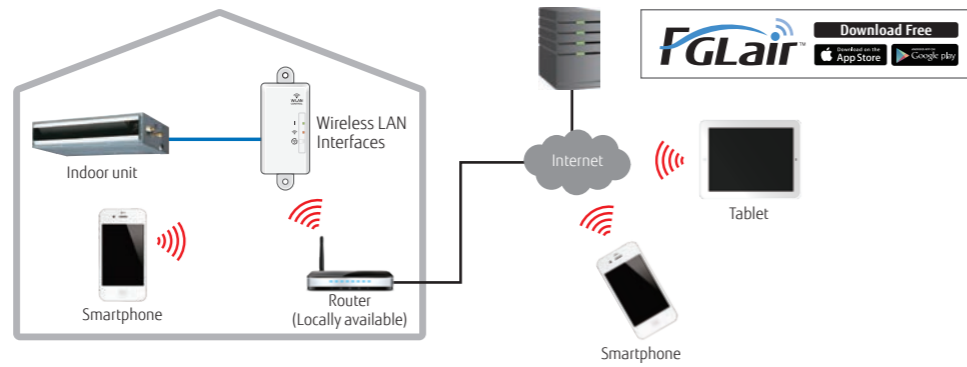

Basic control

- Turning the units on and off
- Mode control (Heat, Cool, Dry, Auto, Fan)
- Fan speed control
- Louver position (airflow direction setting)
- Timer operation setting (Weekly timer)
- Economy mode setting

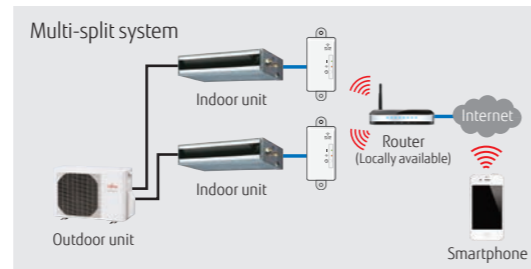

Multiple air conditioning management

- Manage multiple air conditioning systems in different locations.

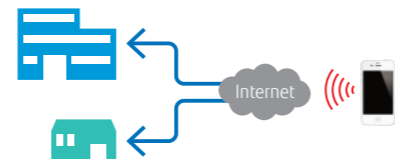

Error alert and e-mail notice

- E-mail notification alerts
- Air conditioning malfunction alert
- Enables quick service response when errors occur.

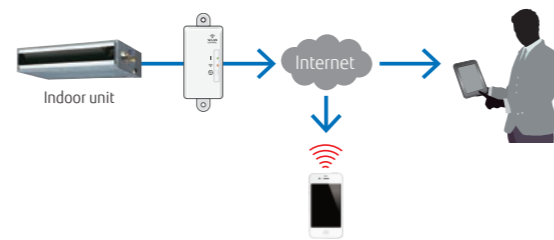

WLAN adapter (USB type) UTY-TFSXF2

A compact USB type is available. No need for specialized installation. Easily installed on the indoor unit.



Specifications

Model name	UTY-TFNXZ1 (3-wire RC-line type)	UTY-TFSXZ1 (CN connector type)	UTY-TFSXF2
Dimensions (H × W × D) (mm)	71 × 38 × 15	71 × 38 × 15	56.7 × 34 × 9.72
Weight (g)	35	35	30

WLAN adapter

FG-RC-WIF1Z2 / FG-IR-WIF1Z1 / FG-AC-WIF1Z1



FG-RC-WIF1Z2
(3-wire RC-line type)



FG-AC-WIF1Z1
(CN connector type)



FG-IR-WIF1Z1
(IR type)

Up to
1 indoor units

AC Cloud Control

- This interface provides the most advanced solution for the remote management of an air conditioning system by using smartphones, tablets, and computers.
- No separate external power supply required

Installation example

[3-wire RC-line type/CN connector type]

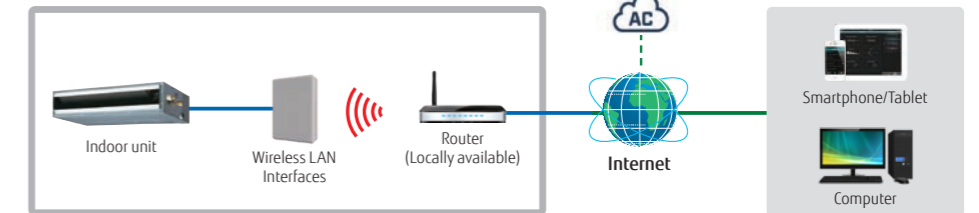

[IR type] Connection to wall-mounted type

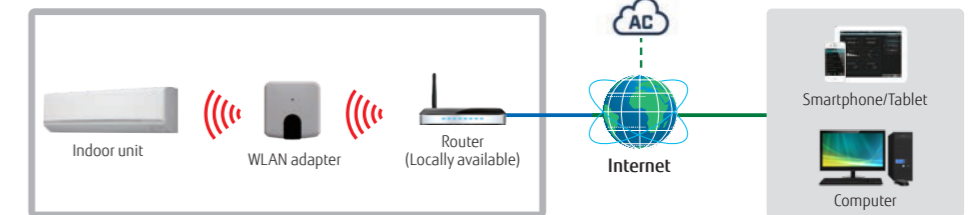

[IR type] Connects to the product with the optional receiver kit

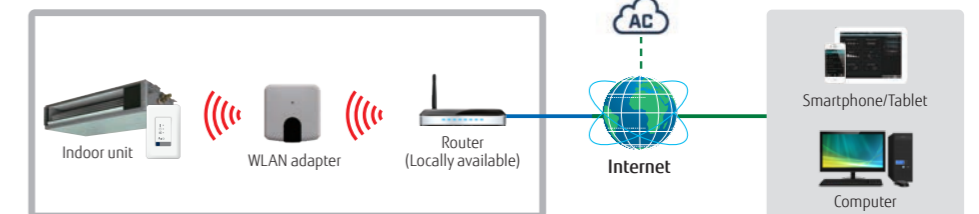

*IR receiver required.

Basic control

- Turning air conditioner on and off
- Mode select (Heat, Cool, Dry, Auto, Fan)
- Louver position (airflow direction setting)
- Fan speed control
- Room temperature display
- Setting temperature
- Multiple language support
- One single scene is created.

Advanced control (optional functions)

- Climate-based operation modes (ECO, Comfort, and Powerful) (to be available in the future)
- Schedule functions (ON/OFF, modes, set temperature, fan speed, louver position)
- Setting temperature range limitation
- Multiple Scenes and Calendars are created.
- Smart Speaker compatibility
- Advanced internet service connections

Notification and operation history

- E-mail notification alerts
- Air conditioning malfunction alert
- Connectivity monitoring and alert
- Operation history (to be available in the future)

Specifications

Model name	FG-RC-WIF1Z2 (3-wire RC-line type)	FG-AC-WIF1Z1 (CN connector type)	FG-IR-WIF1Z1 (IR type)
Number of controllable groups	1	1	1
Dimensions (H × W × D) (mm)	108 × 70 × 28	81 × 78 × 28	127 × 50 × 17
Weight (g)	80	76	80

Multiple protocol WLAN adapter

FG-RC-WMP1Z1 / FG-IR-WMP1Z1 / FG-AC-WMP1Z1



Intesis
BY HBS NETWORKS



FG-RC-WMP1Z1
(3-wire RC-line type)

Intesis
BY HBS NETWORKS



FG-AC-WMP1Z1
(CN connector type)

Intesis
BY HBS NETWORKS



FG-IR-WMP1Z1
(IR type)

Up to
1 indoor units

Specifications

Model name	FG-RC-WMP1Z1 (3-wire RC-line type)	FG-AC-WMP1Z1 (CN connector type)	FG-IR-WMP1Z1 (IR type)
Number of controllable groups	1	1	1
Dimensions (H × W × D) (mm)	70 × 100 × 28	127 × 50 × 17	81 × 78 × 28
Weight (g)	98	80	76

Multiple protocol LAN adapter

FG-TL-MBS16Z1



Intesis
BY HBS NETWORKS



FG-TL-MBS16Z1
(VRF type)

Up to
16 indoor units

Specifications

Model name	FG-TL-MBS16Z1 (VRF type)
Power supply	9 to 36 V DC, Max.: 140 mA or 24 V AC 50/60 Hz, Max.: 127 mA.*
Input power (W)	1.7
Dimensions (H × W × D) (mm)	90 × 88 × 56
Weight (g)	330

*24 V DC power supply is recommended.

AC Cloud Control

- Air conditioner control of Home Automation systems via wireless LAN connection.
- No separate external power supply required

Installation example

[3-wire RC-line type/CN connector type]

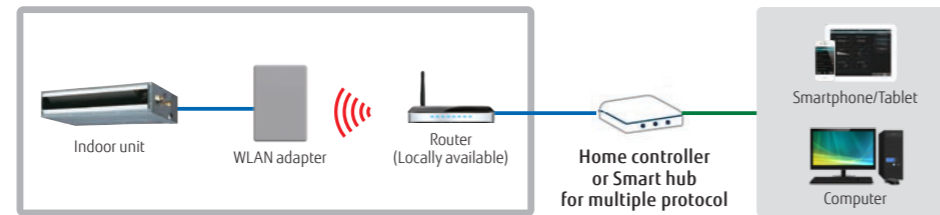

[IR type]

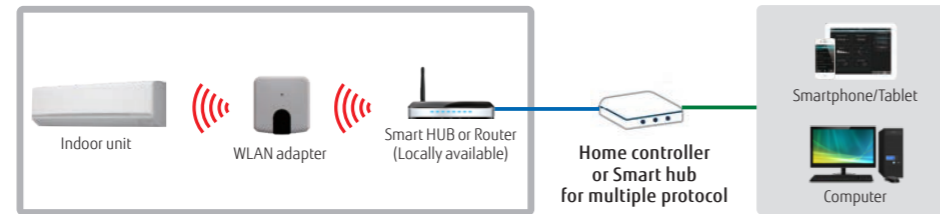

*IR receiver required for other than wall-mounted type.

Home central remote controller

UTY-DMMYM / UTY-DMMYM1



Up to
1 multi-split system
Up to
6 indoor units

For 5-unit and 6-unit multi-split type

- Batched control of up to 6 indoor units For all indoor units connected to the remote controllers, the Home central remote controller sets room temperature, airflow volume, and remote controller prohibition from other remote controllers at once.
- Supports 9 languages: English, French, German, Greek, Italian, Portuguese, Russian, Spanish, and Turkish.
- Large backlit LED screen
- Large, easy-to-see operation panel

Example of system configuration

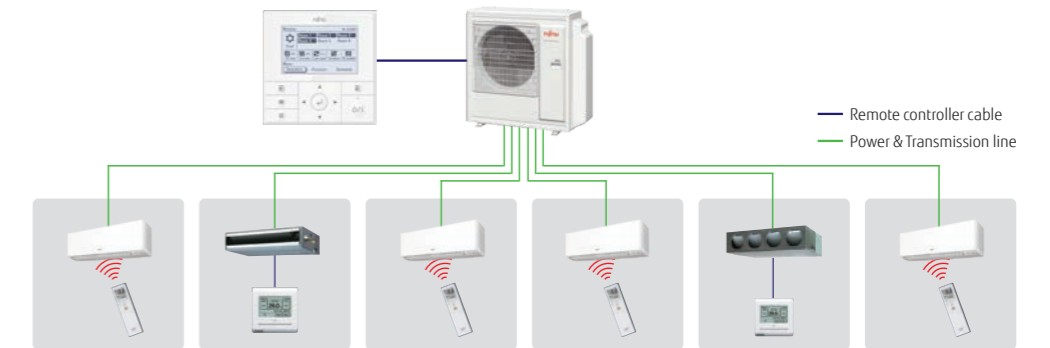

Home central remote controller

Weekly timer

Up to 4 ON/OFF settings can be programmed per day. Two weekly patterns can be set, one for the cooling season and the other for the heating season.

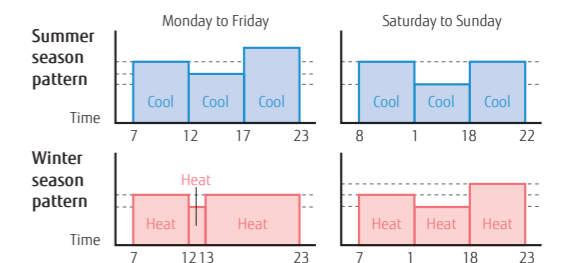

Low noise operation

You can choose from 4 low noise levels depending on the installation environment. ON/OFF timing of low noise mode can be set with the timer.

10°C heat operation

When you leave the house, the air conditioner runs a minimum heating operation to maintain the room temperature at 10°C.

*Consult your dealer for conditions of use.

Economy operation

When you select energy-saving economy mode, the temperature setting for the indoor unit increases (during cooling operation) or decreases (during heating operation) by 1°C and the maximum electric value of the outdoor unit is suppressed.

Prohibiting local control, including settings such as child lock

The Home central remote controller is equipped with a lock function to prevent unauthorized operation from the remote controllers of the indoor unit in each room. The Home central remote controller is equipped with a child lock to prevent children from accidentally turning the air conditioner on or off or changing its settings.

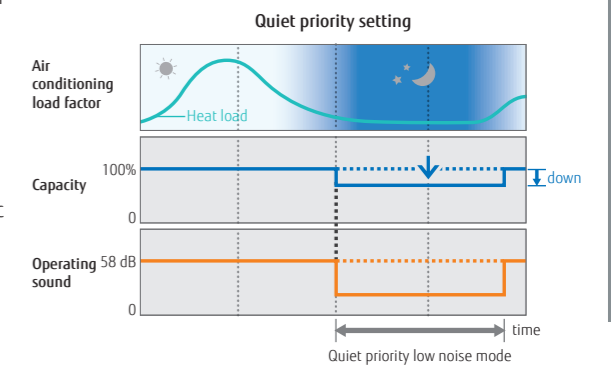

Specifications

Model name	UTY-DMMYM/UTY-DMMYM1
Power source	12 V DC
Dimensions (H × W × D) (mm)	120 × 120 × 21.3
Weight (g)	220

12 V DC supplied by an indoor unit

Central Remote Controller

UTY-DCGYZZ



Up to **100** indoor units
Up to **50** groups

For tenants in small to midsize commercial premises

- Individual control and monitoring of up to 100 indoor units
- 7.0inch TFT color screen
- Visually intuitive operation
- Room temperature display by indoor unit sensor & remote controller sensor
- 50 Remote Controller Groups Display & remote controller group rename
- Supports 12 languages: Chinese, Dutch, English, French, German, Greek, Italian, Polish, Portuguese, Russian, Spanish, and Turkish

Easy operation

Air conditioning management by detecting room temperatures of each room

The room temperature detected with indoor unit sensor or remote controller sensor can be displayed. New model can detect the room temperature by indoor units sensors even if wired remote controllers are not connected to the indoor units.

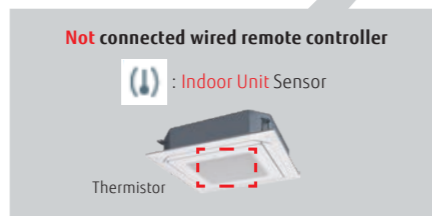

*Room temperature is displayed only when indoor unit operates.

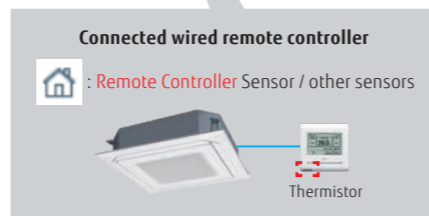

50 Remote Controller Groups Display

The group display and the 50 remote controller groups display can be switched easily. Users can choose which display is better, depending on the situation.

Group Display



Manage & Monitor by each Groups

50 Remote Controller Groups Display

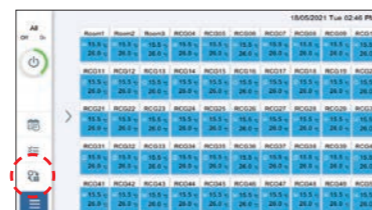

Manage & Monitor by 50 Remote Controller Groups



Remote Controller Groups Rename

The remote controller group names can be changed. Users can know easily where the air conditioning is located by changing the remote controller group names.



Features: Central Remote Controller

- Easy intuitive operation from the touch panel display.
- All functions can be accessed through the monitoring screen showing a pop-up window for detailed operation.

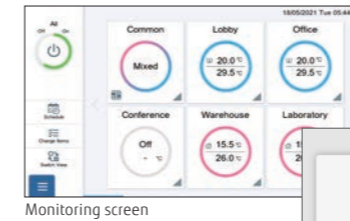

Monitoring screen

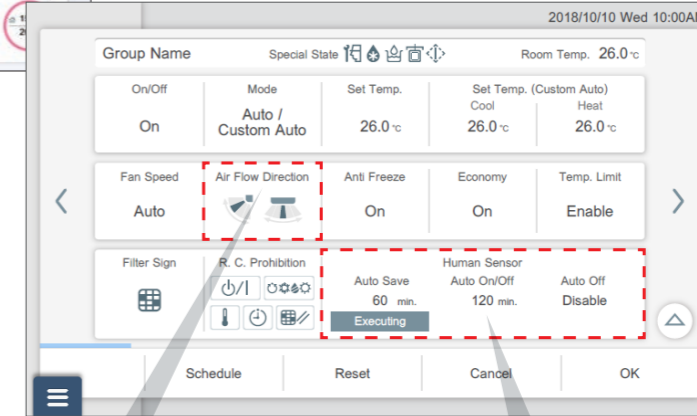

Individual setting

Added individual wind direction control

Individual wind direction control has been added.
Circular Flow cassette / 3D Flow cassette



Circular flow cassette

Occupancy sensor Compatible

Occupancy sensor setting
• Auto save
• Auto on / off
• Auto off detection time
• Enable and disable

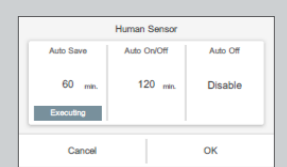

Remote Management

Remote monitoring / Remote operation

New central remote controller can control your tenant's air conditioner anytime and anywhere.

When the central remote controller manages the indoor units of some tenants, air conditioning of each tenant can be managed separately online.

Increased the Number of Accounts

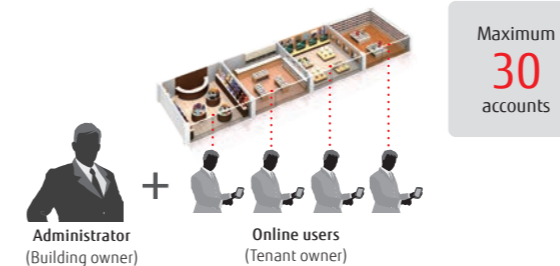

Trouble support function

Display error details

Display descriptive explanation when an error occurs



Sensor value monitoring function

Monitor sensor data of indoor unit / outdoor unit, send mail

Notify room temperature by email*

Notify by e-mail when the temperature around the air conditioner is too high or too low

*This function is available only when using wired remote controller.

Specifications

Model name	UTY-DCGYZZ
Power Supply	100-240 V 50/60 Hz
Dimensions (H × W × D) (mm)	134.6 × 216.2 × 37.9
Weight (g)	800

Touch panel controller

UTY-DTGYZ1



- Large 7.5-inch TFT color LCD screen
- Touch screen operation
- Stylish design to fit nicely into any room environment
- Controls up to 400 indoor units.
- Icon or list view can be selected in monitoring mode.
- Supports 7 languages: Chinese, English, French, German, Polish, Russian, and Spanish.
- Mounted with LAN adapter for remote control & operation, external input/output with emergency stop and batch ON/OFF

Up to
400 indoor units
Up to
100 outdoor units
Up to
400 groups

Easy operation

- Wide range of simple-to-understand icons
- Operate by pressing the icons on the screen with your finger or a stylus.
- The color on the back identifies the current control operation; blue is for monitoring and green is for operational control.

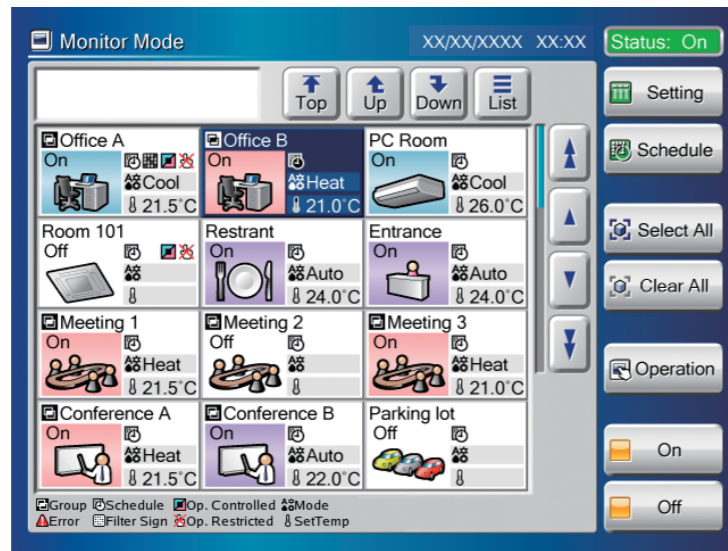

Easy maintenance

- The flat touch panel can be easily cleaned.
- Touch panel controller with non-glare coating to prevent finger marks
- Front cover for easy removal.



Easy installation

- The touch panel controller can be mounted on a wall.
- Flat back surface enables easy installation anywhere on a wall.
- No additional parts or components required for installation



Controls up to 400 indoor units.

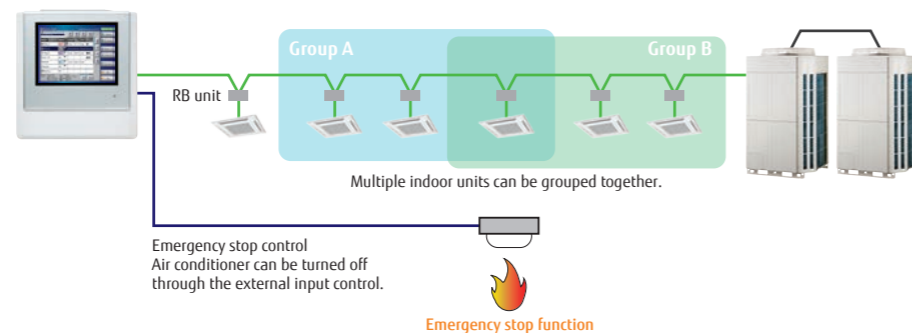

Features:

Control & monitoring

- Control and monitor Fujitsu General air conditioners via LAN or internet.
- Users and tenants can manage their assigned equipment from anywhere by computer or tablet.
- When something goes wrong, an error notice is sent by e-mail for prompt troubleshooting.

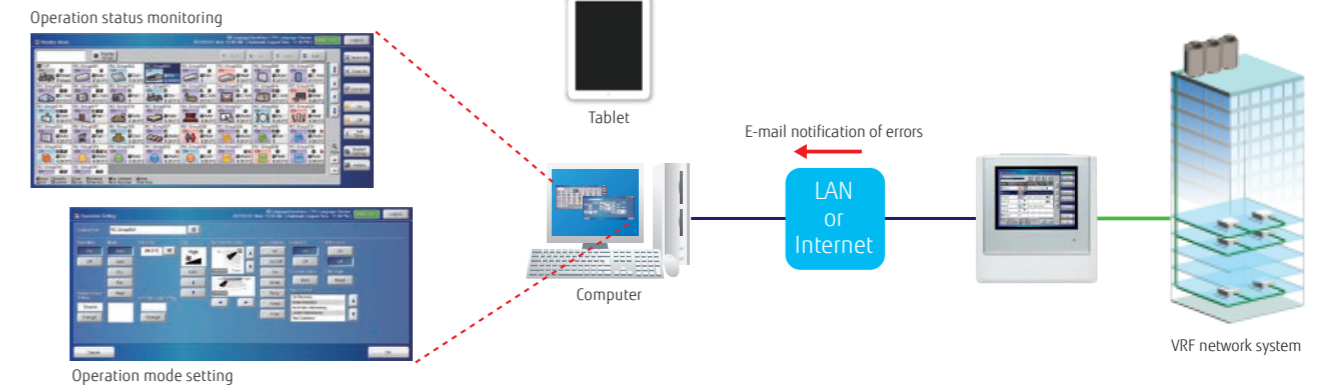

Smartphone

Model name	Browser
Nexus 6P (Android 7.1.1)	Google Chrome 5.5
iPhone 7 (iOS 10.1)	Safari 10

Tablet

Model name	Browser
iPad Pro 9.7 inch (iOS 10.2.1)	Safari 10

Flexible access permissions can be granted to users at each point level.

The administrator can register multiple users and permit them to access any indoor unit and any functions.

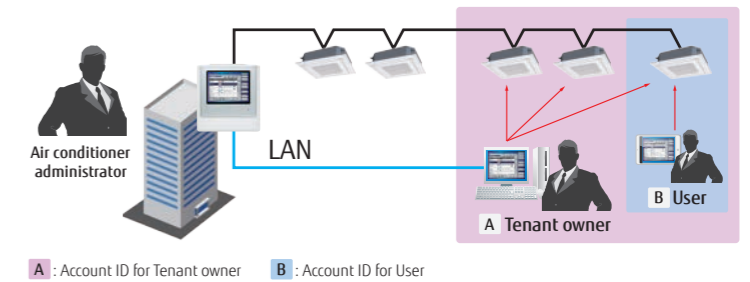

Additional languages

Supports 7 languages as standard: Chinese, English, French, German, Polish, Russian, and Spanish. Create a language database to integrate additional languages into the remote device. The added languages will only be displayed on the remote device and cannot be added to the Touch panel controller.

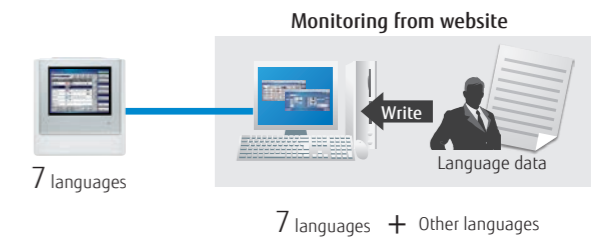

Electricity charge apportionment (Option: UTY-PTGXA)

- Energy cost can be calculated and allocated to each billing user in proportion to the amount of energy used for air conditioning.

- Apportionment charge/bill calculation
- Tenant (block) setting
- Common facilities apportionment setting
- Rated power consumption allotment setting
- Individual calculations for cooling and heating
- Electricity meter supported

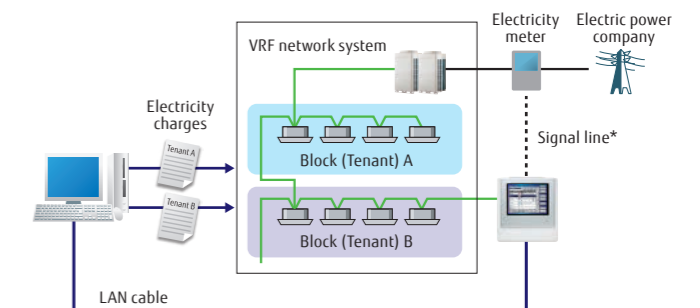

* An electricity usage meter can be connected to an external input connector of the Touch panel controller. In that case, the meter cannot be connected to an outdoor unit at the same time.

Features:

Automatic setting for daylight saving time

Functions provided

- 1) Schedule setting for daylight saving time
 - It prevents the user from forgetting to set daylight saving time. In addition, it saves time and effort for the user.

Automatic clock adjustment

- 2) Time can be set for all controllers in a batch automatically.

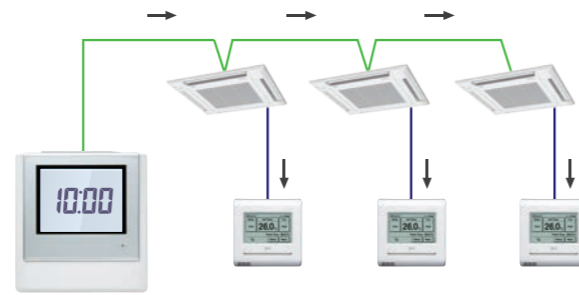

Outdoor unit low noise operation

You can choose from 4 low noise levels depending on the installation environment. ON/OFF timing of low noise mode can be set with the timer.

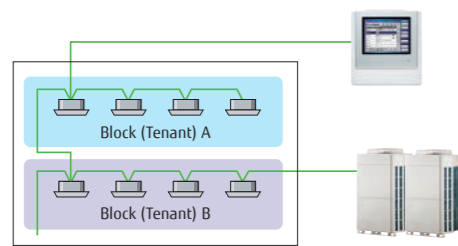

Quiet priority setting

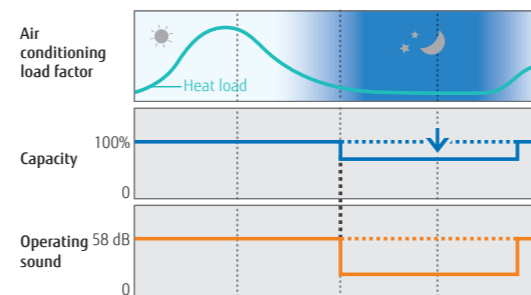

Energy-saving controls

Custom Auto

- Maintains 2 separate setpoints for heating and cooling operations.
- Automatically switches between heating and cooling modes.

* Not available for some models



Cooling set temp. 28°C, Heating set temp. 18°C

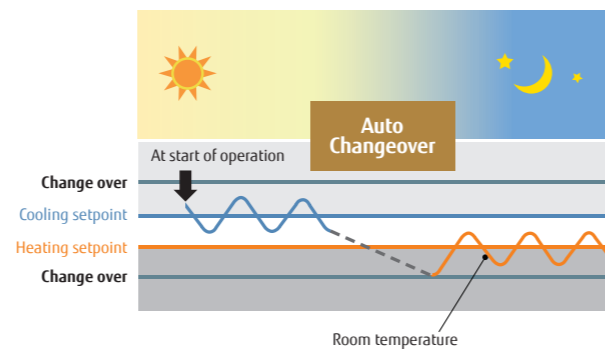

Refrigerant leak detector

Refrigerant leakage status is indicated by the management equipment. A pop-up message is displayed to notify the user, and the refrigerant is shut off.



FUNCTIONS SUMMARY

	UTY-DTGYZ1	Monitoring side
Air conditioning control functions		
ON/OFF	●	●
Operation mode setting*	●	●
Fan speed control	●	●
Room temperature setting	●	●
Setting temperature range limitation	●	●
Test operation	●	●
Vertical louver setting	●	●
Horizontal louver setting	●	●
Individual louver control	●*1	●
Group setting	●	●
Remote controller prohibition	●	●
Anti-freeze setting	●	●
Set temperature auto return	—	●
Energy-saving controls	—	●
Economy mode setting	●	●
Occupancy sensor control	—	●
Displayed items		
Error	●	●
Defrosting	●	●
Current time	●	●
Day of week	●	●
Remote controller prohibition	●	●
Cooling/heating priority	●	●
Address display	●	●
Room temperature	●*3	●*3
Multiple language support	●	●
Setting for daylight saving time	●	●
Time zone setting	●	●
Name registration	●	●
Backlighting	●	●
Language setting	7	7+ other
Filter sign reset	●	●
Memory operations	●	●
Refrigerant leak detector	●	●

●: Supported ○: Optional function —: Not supported
 *1 Only setting cancellation can be operated.
 *2 Only available for external input control.
 *3 Available only when using a Wired remote controller.

Specifications

	UTY-DTGYZ1
Model name	UTY-DTGYZ1
Power supply	Single phase ~100 to 240 V 50/60 Hz
Dimensions (H × W × D) (mm)	260 × 246 × 54
Weight (g)	2,150
Interfaces	Transmission/LAN/USB/EXT IN/EXT OUT/Reset SW

	UTY-DTGYZ1	Monitoring side
Timer		
	Period	Year
Schedule timer	ON/OFF, Temp, Mode, Times per day	20
		Year
ON/OFF timer	—	—
Sleep timer	—	—
Program timer	—	—
Auto-off timer	—	●
Day off	●	●
Minimum unit of timer setting (minutes)	10	10
Control		
Remote monitoring management system	●	●
Electricity charge apportionment	○	○
Error history	●	●
Emergency stop	●*2	●*2
Remote monitoring management	—	●
Energy-saving management	—	—
E-mail notification in case of failure	—	●
Key lock	● Password setting	—
Low noise mode	●	●

System controller

UTY-APGXZ1 **Software**

Up to
4 VRF network systems
Up to
400 outdoor units
Up to
1,600 indoor units

System controller enables advanced integrated monitoring and control of VRF network systems operating in small to large buildings.

- Up to 1,600 indoor units and 400 outdoor units on up to 4 VRF network systems can be controlled.
- To accommodate facility management needs, the system controller offers—in addition to precise air conditioning control—remote central control, electricity charge apportionment, schedule management, and energy-saving options for VRF network systems.
- Supports 7 languages: Chinese, English, French, German, Polish, Russian, and Spanish.



System controller Lite

UTY-ALGXZ1 **Software**

Up to
1 VRF network systems
Up to
100 outdoor units
Up to
400 indoor units

System controller Lite offers a set of standard functions to manage air conditioners operating in a small or midsize building.

- Up to 400 indoor units and 100 outdoor units on a VRF network system can be controlled.
- In addition to precise air conditioning control, a variety of applications are available as options to offer a wider range of control.
- Supports 7 languages: Chinese, English, French, German, Polish, Russian, and Spanish.



Visually intuitive operation

Click & Operate: The visual representation of the property is shown on the screen from the perspective most suitable for operation (Click & Operate) You can select from among 4 display options: site, building, floor, and list.

Freely define groups for batched control: Indoor units can be grouped for simplified batch control from the tree menu. They can be grouped by organizational hierarchy, such as by division, department, and section.

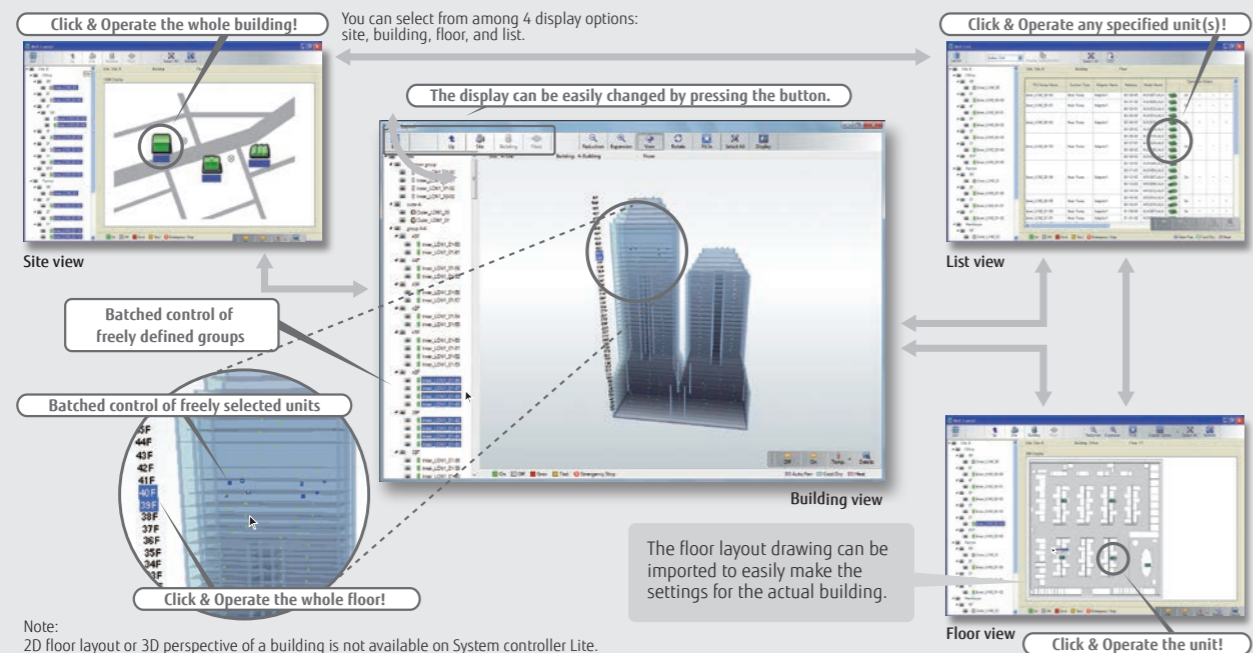

Features:

Third-party devices connected via MODBUS® can be controlled.

Standard for System Controller **Option** for System controller Lite UTY-PLGXX2

When a MODBUS® adapter (locally available) is connected to a computer, electrical equipment and devices supported by MODBUS® can be monitored and controlled centrally from the computer. The central control can reduce wasted energy throughout an entire building resulting from a failure to turn equipment off during or after work, as well as reduce the need for on-site patrols.

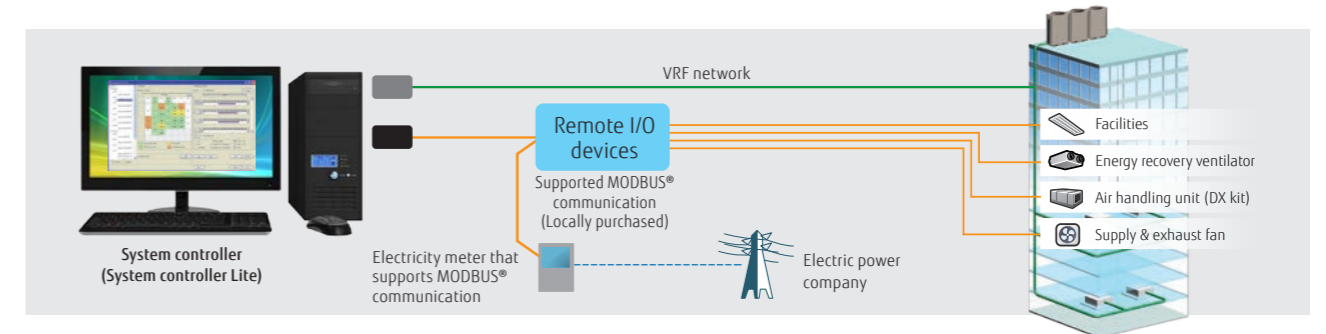

Wide-ranging operation and data management

Standard System controller and System controller Lite

Schedule management

- An annual schedule can be arranged for each remote controller group or user-defined group.
- ON/OFF, operation mode, remote controller prohibition, and temperature settings can be programmed for up to 143 times per day at 10-minute intervals and for up to 101 configurations for each remote controller group.
- Settings can be programmed for a period that spans midnight.
- Allows for the programming of special settings for weekends, holidays, and store closings throughout the year.
- Low noise operation of outdoor units can be scheduled.

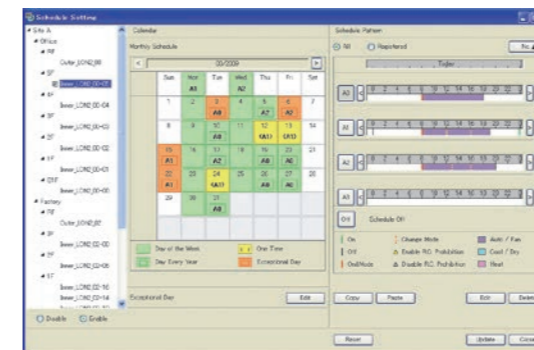

Wide-ranging control of indoor and outdoor units

- The operation status and mode of each indoor unit are displayed.
- Turn on and off each indoor unit and switch its operation mode.
- Setting temperature range limitation
- Low noise setting of outdoor units

Remote controller prohibition

Prohibits the operation mode, temperature setting, or ON/OFF of an indoor unit.

Error alert and e-mail notice

When something goes wrong, an error message is shown in a popup on a computer display with a chime, and an e-mail notice is sent. Errors of the past one year are logged and can be reviewed.

Operation and control history

A history of operation status and control can be maintained and retrieved.

Importing and exporting databases

Only an administrator is authorized to import and export registration, layout, and image data.

Automatic clock adjustment

Time can be set for all controllers in batch automatically.

Electricity charge apportionment

Standard on System controller
Option System controller Lite UTY-PLGXA2

Electricity charge apportionment method

This is a method to calculate monthly energy costs to be allocated to each tenant based on the amount of energy used by their air conditioners. The first step is to determine exactly how much energy is consumed by air conditioners in each tenant space. The second step is to divide the total energy charge billed by an electric power company based on the amount of energy used by each tenant to determine the energy cost to be allocated to each of them. (See figure on right) The calculation takes into consideration such factors as the number of unused rooms and nighttime electricity rate, which are shown in detail on an energy cost allocation schedule.

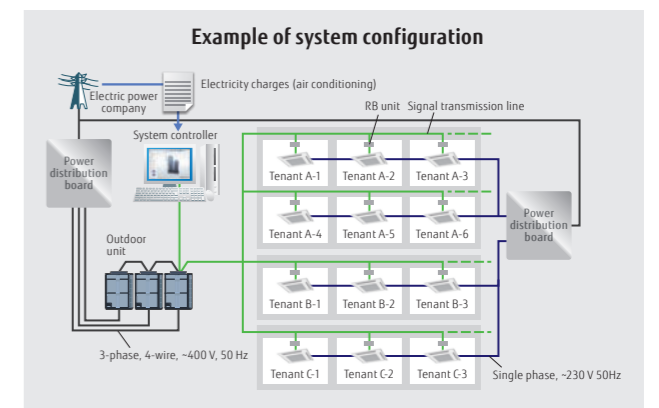

Features:

Remote monitoring management

- Standard** on System controller
- Option** System controller Lite UTY-PLGXR2

The System controller can be used on site or remotely over networks for remote central control. The System controller requires 2 software programs working together: The VRF controller runs on site and communicates with the VRF system; The VRF explorer, which runs at a remote location, provides a user interface and communicates with the VRF controller. The VRF controller and the VRF explorer run on a single computer or on different computers connected on a network. A computer running VRF explorer can centrally control up to 10 VRF system sites having up to 20 buildings each.

On site central control

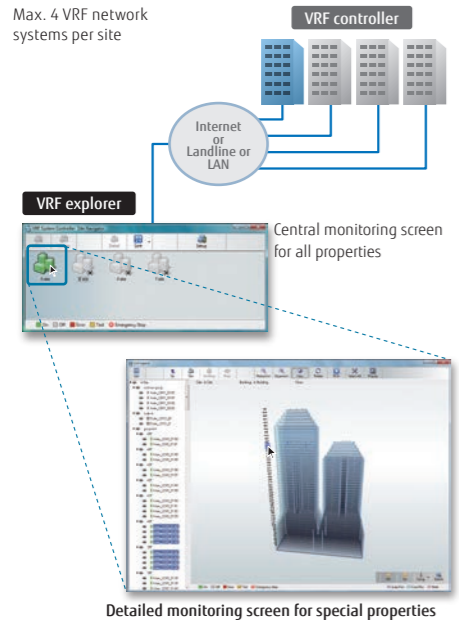

Remote central control

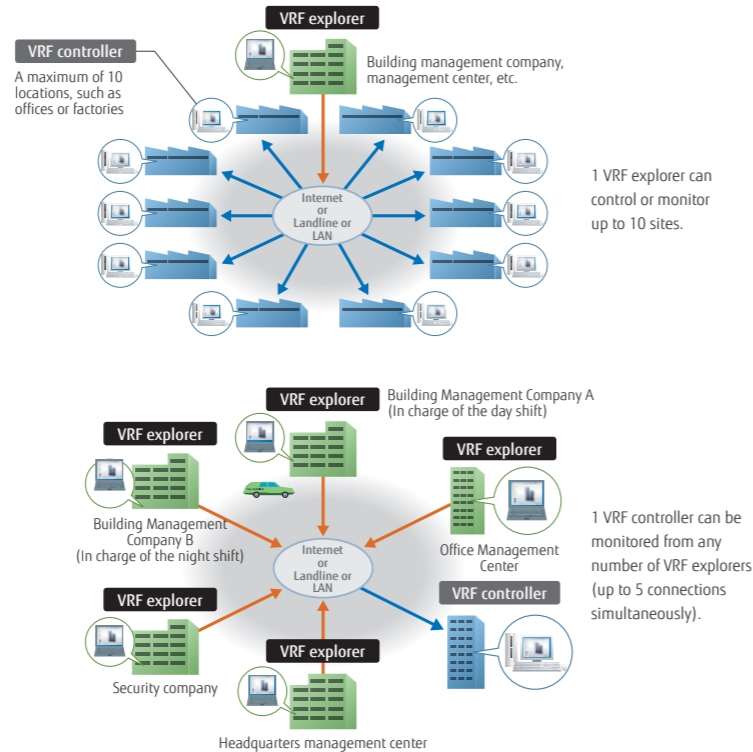

Energy-saving management

- Option** System controller UTY-PEGXZ1
- Option** System controller Lite UTY-PLGXE2

A variety of energy-saving options can be selected depending on the season, weather, and time of day. Excellent energy-saving operation is performed while keeping users comfortable.

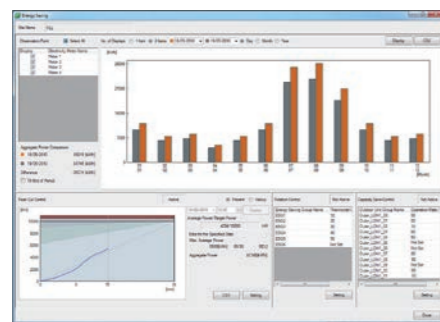

Main screen for energy-saving management

Energy saving graph data: This chart compares the energy consumption for the current month with the previous month and with the same month of the previous year to keep track of the energy-saving performance.

Indoor unit rotation

Indoor units can be automatically rotated to operate within a group in accordance with a predetermined annual schedule to reduce power consumption while keeping users comfortable. The operation stoppage rate can be selected for an indoor unit.

Peak-cut mode

The system controller monitors the connected power meter and controls the energy to maintain the target power consumption set for each time period by changing the set temperature of the indoor units or turning off the thermostat so as to keep the users comfortable. Indoor units to be controlled can be grouped in many ways, and the control level can be set for each group.

Capacity saving for outdoor unit

The upper limit on the capacity of an outdoor unit can be adjusted to reduce power consumption during a hot summer or cold winter by averaging out the power-saving performance of each refrigerant system. The upper limit on capacity can be set at 50% of the rated capacity or more.

Summary of functions

Functions	Type	System controller		System controller Lite				
		UTY-APGXZ1	Option UTY-PEGXZ1	UTY-ALGXZ1	Option UTY-PLGXR2	Option UTY-PLGXA2	Option UTY-PLGXE2	Option UTY-PLGXX2
Specifications	Max. number of VRF networks supported	4	—	1	—	—	—	—
	Max. number of indoor unit and remote controller groups per VRF network	400	—	400	—	—	—	—
	Max. number of outdoor units per VRF network	100	—	100	—	—	—	—
	Max. number of indoor units and remote controller groups per System controller	1600	—	400	—	—	—	—
Site supervision	Multiple site display	10	—	10	—	—	—	—
	Number of buildings per site	20	—	—	—	—	—	—
	Number of floors per site	200	—	—	—	—	—	—
	Number of floors per building	50	—	—	—	—	—	—
	3D graphical layout view	●	—	—	—	—	—	—
	2D graphical layout view	●	—	—	—	—	—	—
	List display	●	—	●	—	—	—	—
Error management	Error notification	●	—	●	—	—	—	—
	Audible alarm	●	—	●	—	—	—	—
	E-mail notification of errors	●	—	●	—	—	—	—
History	Error history	●	—	●	—	—	—	—
	Operation history	●	—	●	—	—	—	—
Operation control	Individual control	ON/OFF	●	—	●	—	—	—
		Operation mode*	●	—	●	—	—	—
		Room temperature	●	—	●	—	—	—
	Individual management	Fan speed	●	—	●	—	—	—
		Airflow direction	●	—	●	—	—	—
		Economy mode	●	—	●	—	—	—
		Setting temperature range limitation	●	—	●	—	—	—
		Anti-freeze	●	—	●	—	—	—
		Low noise setting of outdoor units	●	—	●	—	—	—
	Other	Remote controller prohibition	●	—	●	—	—	—
		Setting temperature range limitation	●	—	●	—	—	—
		Filter sign reset	●	—	●	—	—	—
	Schedule	Annual Schedule	Annual Schedule	●	—	●	—	—
Setting for a specific date			●	—	●	—	—	—
ON/OFF per day		ON/OFF per day	72	—	72	—	—	—
		ON/OFF per week	504	—	504	—	—	—
Day off		Day off	●	—	●	—	—	—
		Minimum unit of timer setting (minutes)	10	—	10	—	—	—
Weekly schedule for low noise mode		●	—	●	—	—	—	
Remote monitoring management		Web Operation	●	—	●	—	—	—
		Remote monitoring	●	—	●	—	—	—
		Remote operation control	●	—	●	—	—	—
	Remote function setting	●	—	●	—	—	—	
Electricity charge apportionment	Apportionment charge/bill calculation	●	—	●	—	—	—	
	Tenant (block) setting	●	—	●	—	—	—	
	Common facilities apportionment setting	●	—	●	—	—	—	
Energy-saving management	Rated power consumption allotment setting	●	—	●	—	—	—	
	Individual calculations for cooling and heating	—	●	—	●	—	—	
	Electricity meter supported	—	●	—	●	—	—	
	Indoor unit rotation	—	●	—	●	—	—	
	Peak cut control	—	●	—	●	—	—	
Control of external devices	Capacity saving for outdoor unit	—	●	—	●	—	—	
	Record of energy-saving operation	—	●	—	●	—	—	
	Information on energy saving	—	●	—	●	—	—	
	Power consumption monitor	—	●	—	●	—	—	
Others	Electricity meter supported	—	●	—	●	—	—	
	Monitor	●	—	●	—	—	—	
	Control	●	—	●	—	—	—	
	Importing and exporting databases	●	—	●	—	—	—	
	Automatic clock adjustment	●	—	●	—	—	—	
Multiple language support	7 languages	—	7 languages	—	—	—		
Refrigerant leak detector	●	—	●	—	—	—		
Power shutdown	●	—	●	—	—	—		

●: Available - : Not available

Computer requirements

The specifications required for the computer are shown in the table below:

	System controller	System controller Lite
Operating system	<ul style="list-style-type: none"> Microsoft® Windows® 7 Home Premium (32-bit or 64-bit) SP1, Windows® 7 Professional (32-bit or 64-bit) SP1 Microsoft® Windows® 8.1 (32-bit or 64-bit), Windows® 8.1 Pro (32-bit or 64-bit) Microsoft® Windows® 10 Home (32-bit or 64-bit), Windows® 10 Pro (32-bit or 64-bit) Supports 7 languages: English, Chinese, French, German, Russian, Spanish, and Polish	<ul style="list-style-type: none"> Microsoft® Windows® 7 Home Premium (32-bit or 64-bit) SP1, Windows® 7 Professional (32-bit or 64-bit) SP1 Microsoft® Windows® 8.1 (32-bit or 64-bit), Windows® 8.1 Pro (32-bit or 64-bit) Microsoft® Windows® 10 Home (32-bit or 64-bit), Windows® 10 Pro (32-bit or 64-bit) Supports 7 languages: English, Chinese, French, German, Russian, Spanish, and Polish
CPU	Intel® Core™ i3 2 GHz or higher	Intel® Core™ i3 2 GHz or higher
Memory	<ul style="list-style-type: none"> 2 GB or more (for Windows® 7 [32-bit]) 4 GB or more (for Windows® 7 [64-bit], Windows® 8.1, and Windows® 10) 	<ul style="list-style-type: none"> 2 GB or more (for Windows® 7 [32-bit]) 4 GB or more (for Windows® 7 [64-bit], Windows® 8.1, and Windows® 10)
HDD	40 GB or more of free space	40 GB or more of free space
Displayed items	1024 × 768 or higher resolution	1024 × 768 or higher resolution
Interfaces	<ul style="list-style-type: none"> Ethernet port (for getting access to the internet using LAN) or a modem (for getting access to the internet via landline) Up to 6 USB ports (Only required for a server computer working as a VRF controller) - Maximum of 2 USB ports are required to connect to a White-USB-key/WibuKey - Up to 4 USB ports required to connect to an Echelon® U10 USB network interface * Maximum number of required USB ports depends on the applicable system configuration. 	<ul style="list-style-type: none"> Ethernet port (for getting access to the internet using LAN) or a modem (for getting access to the internet via landline) Up to 6 USB ports (Only required for a server computer working as a VRF controller) - Maximum of 4 USB ports are required to connect to a White-USB-key/WibuKey - 1 USB port is required for an Echelon® U10 USB Network interface * The maximum number of required USB ports depends on the applicable system configuration.
Graphic accelerator	Microsoft® DirectX® 9.0c compatible	Microsoft® DirectX® 9.0c compatible
Software	Adobe® Acrobat Reader® 9.0 or later	Adobe® Acrobat Reader® 9.0 or later

* Echelon® U10 USB Network interface - TP/FT-10 Channel (Model name: 75010R) (Required for each VRF Network)

Packing list

Type	For System controller			For System controller Lite			
	System controller	Option Energy manager	System controller Lite	Remote access	Option Electricity charge apportionment	Option Energy saving	Option Centralized control
Model name	UTY-APGXZ1	UTY-PEGXZ1	UTY-ALGXZ1	UTY-PLGXR2	UTY-PLGXA2	UTY-PLGXE2	UTY-PLGXX2
White-USB-key	1	1	1	1	1	1	1

*1: Software protection key to be inserted in a USB slot running System controller or System controller Lite. System controller or System controller Lite may only run on a PC with a WHITE-USB-KEY. However, a WHITE-USB-KEY is not required for remote VRF explorer software.

MODBUS® converter for Indoor unit

UTY-VMSX



Up to
1 indoor unit

MODBUS® converter enables air conditioners to be fully integrated into a MODBUS® network.

- Simple installation due to small and compact size.
- No separate external power supply required.
- The MODBUS® converter must be connected to an indoor unit on a one-to-one basis.
- The MODBUS® converter enables central monitoring and control of air conditioners from BMS, central, or home controller.

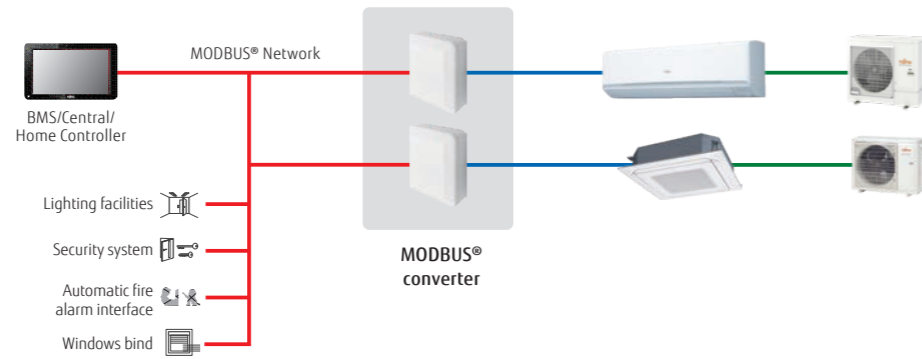

Easy Installation

Easy to install with minimal wiring and without the need for a power supply cable to the converter

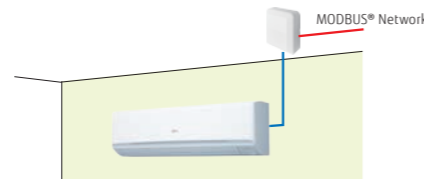

Basic control

- Turning the units on and off
- Mode control (Heat, Cool, Dry, Auto, Fan)
- Fan speed control
- Louver position (airflow direction setting)
- Room temperature setting and display
- Economy mode setting
- Error status

Specifications

Model name	UTY-VMSX
Power supply	12 V DC
Input power (W)	Max. 1.2 W
Dimensions (H × W × D) (mm)	140 × 117 × 43
Weight (g)	200
Maximum number of connectable indoor units per MODBUS® converter	1

Modbus communication specifications

Transfer mode	RTU mode
Communication speed	9600/19200 bps
Data bit	8
Parity	even/odd/none
Stop bit	1/2 (no parity)
Network	RS485
Maximum cable length	1000 m (3280 ft)

MODBUS® interface

FG-RC-MBS1Z1 / FG-AC-MBS1Z1 / FG-IR-BMG1Z1



FG-RC-MBS1Z1
(3-wire RC-line type)



FG-AC-MBS1Z1
(CN connector type)



NEW



FG-IR-BMG1Z1
(IR type)

Up to
1 indoor unit

MODBUS® interface enables air conditioners to be fully integrated into a MODBUS® network.

- Small, compact, and easy to install on DIN rails.
- No separate external power supply required.
- MODBUS® interface enables central monitoring and control of air conditioners from BMS.

Installation example

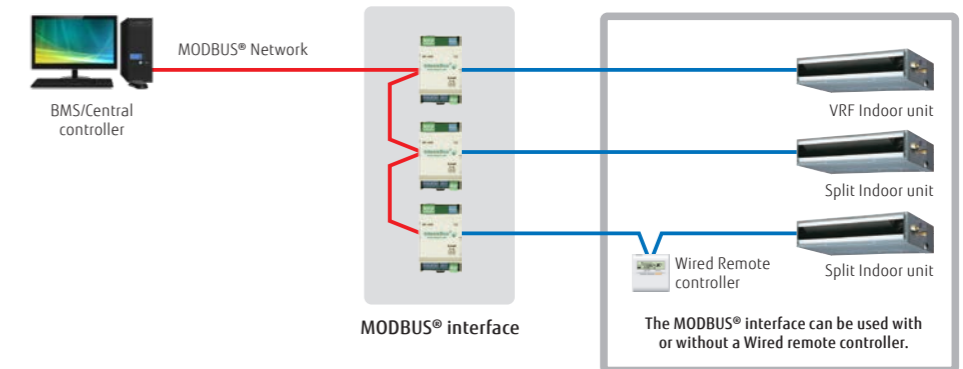

The MODBUS® interface can be used with or without a Wired remote controller.

[IR type] Connection to wall-mounted type

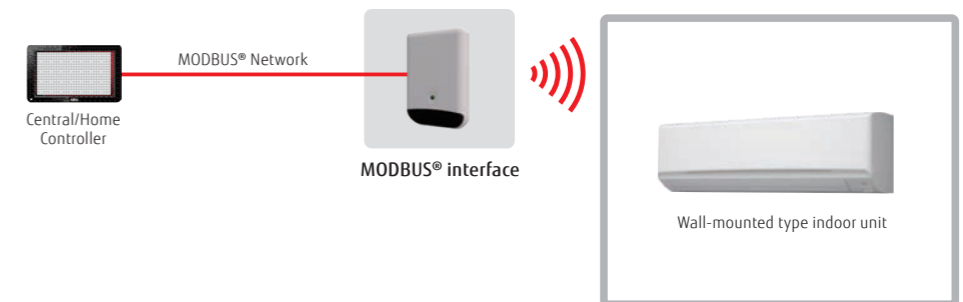

Specifications

Model name	FG-RC-MBS1Z1 (3-wire RC-line type)	FG-AC-MBS1Z1 (CN connector type)	FG-IR-BMG1Z1 (IR type)
Number of controllable groups	1	1	1
Dimensions (H × W × D) (mm)	93 × 53 × 58	93 × 53 × 58	93 × 60 × 21
Weight (g)	85	85	55

MODBUS® convertor for VRF

UTY-VMGX / FG-TL-MBS16Z1

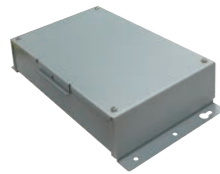

UTY-VMGX

Up to
9 units per VRF system
Up to
100 outdoor units
Up to
128 indoor units

MODBUS® convertor enables air conditioners to be fully integrated into a MODBUS® network.

- Compact and lightweight design
- Direct connection to MODBUS® network
- MODBUS® convertor enables central monitoring and control of air conditioners from BMS or a central controller.
- Up to 9 converters can be connected to a VRF network (UTY-VMGX). Simultaneous control, such as Power ON/ OFF and temperature setting, can be performed for each zone.
- If a connection error occurs after installation work is completed, the source of the error can be located easily.

Installation example



FG-TL-MBS16Z1

Up to
16 indoor units
Up to
16 outdoor units
Up to
128 indoor units

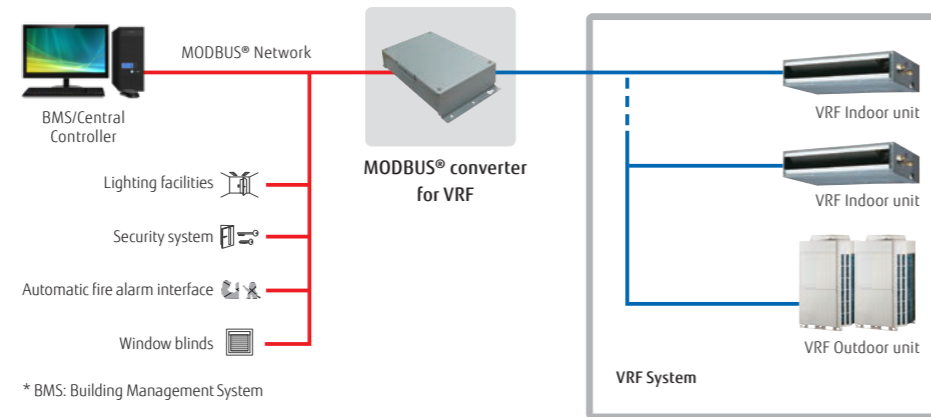

* BMS: Building Management System

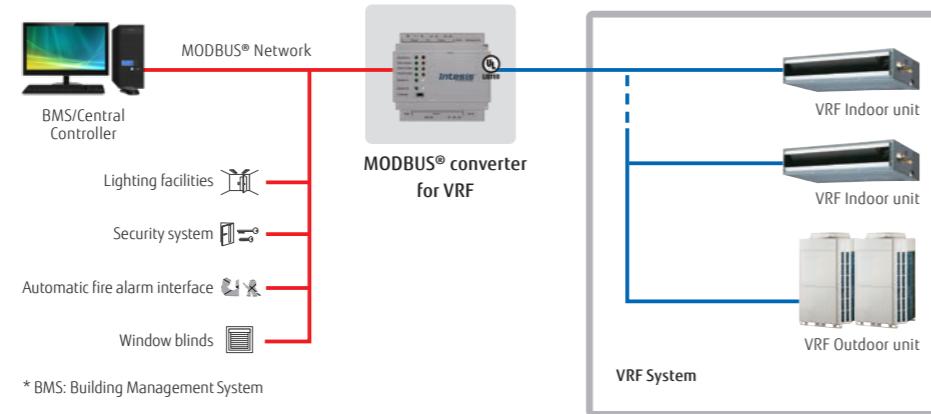

* BMS: Building Management System

Specifications

Model name	UTY-VMGX	FG-TL-MBS16Z1
Power supply	Single phase ~220 to 240 V 50/60 Hz	9 to 36 V DC, Max.: 140 mA or 24 V AC 50/60 Hz, Max.: 127 mA.*
Input power (W)	Max. 2	1.7
Dimensions (H × W × D) (mm)	54 × 260 × 150	90 × 88 × 56
Weight (g)	1,100	330

*24 V DC power supply is recommended.

BACnet® interface

FG-AC-BAC1Z1 / FG-IR-BMG1Z1



FG-AC-BAC1Z1 (CN connector type)



FG-IR-BMG1Z1 (IR type)

NEW

Up to
1 indoor units

- BACnet® interface connects BMS and a Fujitsu General split/multi-split/VRF system.
- Compatible with BACnet® (ANSI/ASHRAE-135-2012) application-specific controller (B-ASC)
- Compatible with BACnet®/IP over Ethernet.

Installation example

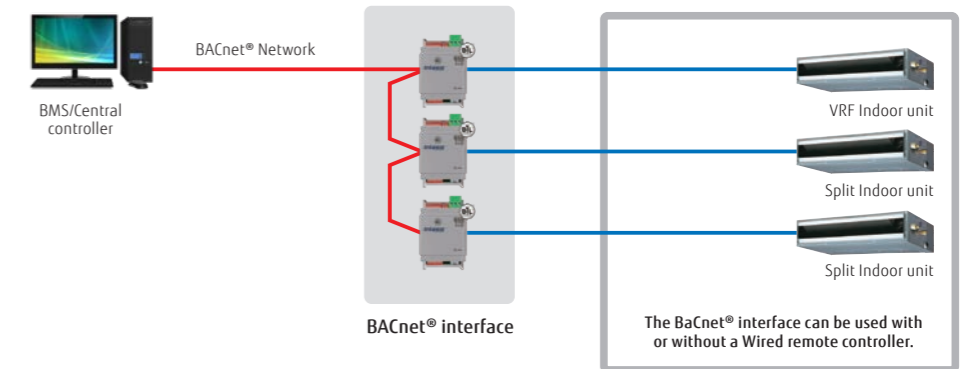

The BACnet® interface can be used with or without a Wired remote controller.

[IR type] Connection to wall-mounted type

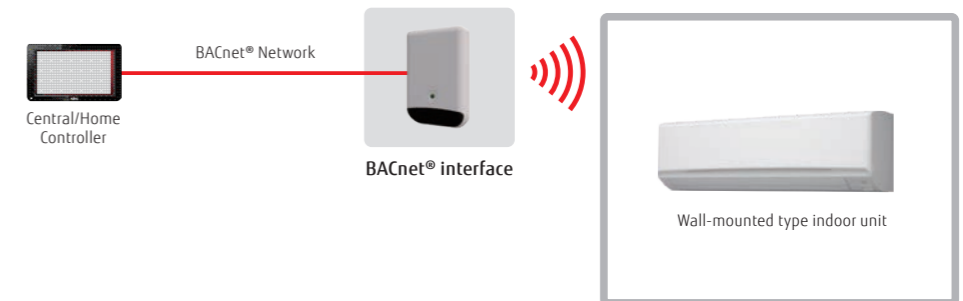

Specifications

Model name	FG-AC-BAC1Z1 (CN connector type)	FG-IR-BMG1Z1 (IR type)
Number of controllable groups	1	1
Dimensions (H × W × D) (mm)	93 × 53 × 58	93 × 60 × 21
Weight (g)	85	55

12 V DC supplied by an indoor unit

BACnet® gateway

UTY-ABGXZ1 (Software)



White-USB-key
(Software Protection Key)



BACnet® is a registered trademark of ASHRAE. ASHRAE does not endorse, approve or test products for compliance with ASHRAE standards. Compliance of listed products to the requirements of ASHRAE Standard 135 is the responsibility of BACnet International (BI). BTL is a registered trademark of BACnet International.

Up to
4 VRF network systems
Up to
400 outdoor units
Up to
1,600 indoor units

Installation example

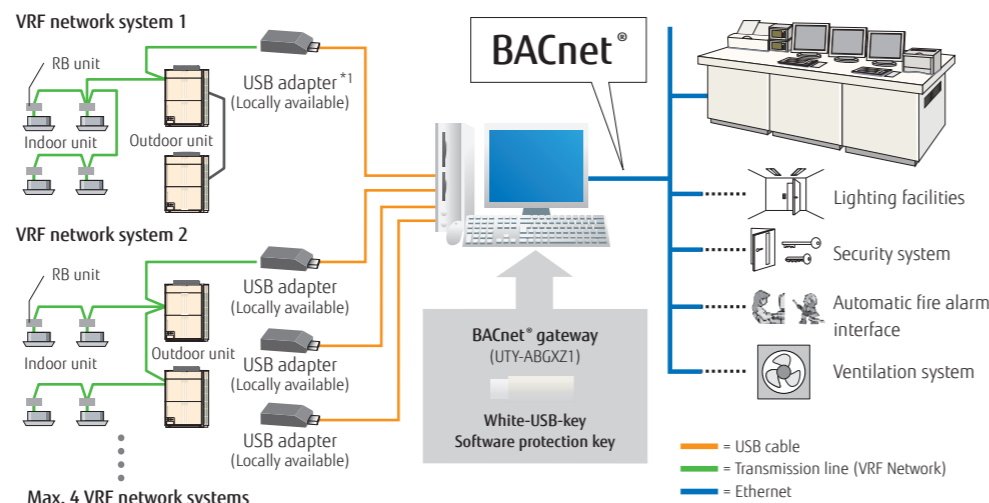

*1: U10 USB network interface available from Echelon® Corporation.

Computer requirements

	UTY-ABGXZ1
Operating system	<ul style="list-style-type: none"> Microsoft® Windows® 7 Home Premium (32-bit or 64-bit) SP1, Windows® 7 Professional (32-bit or 64-bit) SP1 Microsoft® Windows® 8.1 (32-bit or 64-bit), Windows® 8.1 Pro (32-bit or 64-bit) Microsoft® Windows® 10 Home (32-bit or 64-bit), Windows® 10 Pro (32-bit or 64-bit) Supported languages: Chinese, English, French, German, Polish, Russian, and Spanish
CPU	Intel® Core™ i3 2 GHz or higher
Memory	<ul style="list-style-type: none"> 2 GB or more (for Windows® 7 [32-bit]) 4 GB or more (for Windows® 7 [64-bit], Windows® 8.1, and Windows® 10)
HDD	40 GB or more of free space
Displayed items	1024 × 768 or higher resolution
Interfaces	<ul style="list-style-type: none"> Ethernet port (for getting access to the internet using LAN) Up to 5 USB ports - 1 USB port required to connect to a White-USB-key/WibuKey - Up to 4 USB ports required to connect to an Echelon® U10 USB network interface *The maximum number of required USB ports varies depending on the applicable system configuration.
Software	Adobe® Acrobat Reader® 9.0 or later

*Echelon® U10 USB Network interface – TP/FT-10 Channel (Model name: 75010R) (Required for each VRF Network)

Packing list

Name and shape	Quantity	Application
White-USB-key	1	Includes the software, user's manual, and license for BACnet® gateway.

BACnet® gateway

UTY-VBGX (Hardware)



BACnet® is a registered trademark of ASHRAE. ASHRAE does not endorse, approve or test products for compliance with ASHRAE standards. Compliance of listed products to the requirements of ASHRAE Standard 135 is the responsibility of BACnet International (BI). BTL is a registered trademark of BACnet International.

Up to
1 VRF network systems
Up to
32 refrigerant systems
Up to
128 indoor units

Installation example

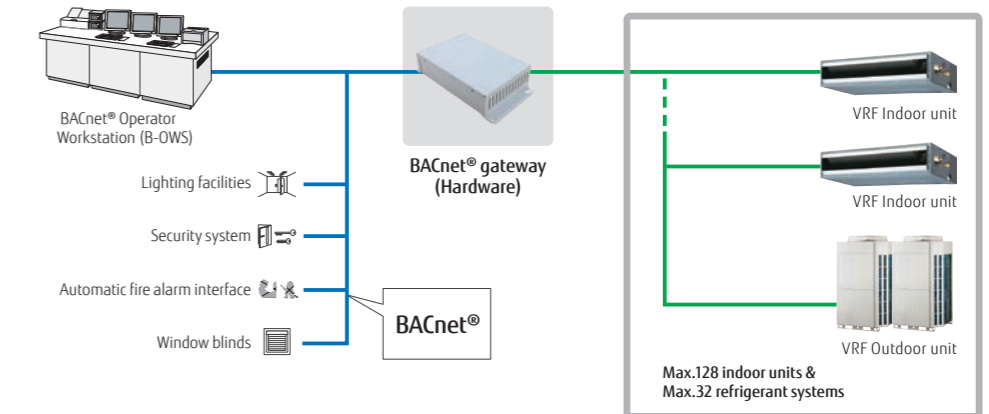

Specifications

Model name	UTY-VBGX
Number of controllable indoor units	128
Number of controllable refrigerant systems	32
Number of controllable VRF networks	1
Number of connectable units / one VRF network	4
Power supply	Single phase, 100-240 V, 50/60 Hz
Power consumption (W)	4.6 (max.)
Dimensions (H × W × D) (mm)	59.6 × 270.4 × 176
Weight (g)	1200

BACnet®/MODBUS® Router

FG-RTR-BAC32Z1 / FG-RTR-MBS32Z1



Intesis
BY HMS NETWORKS



FG-RTR-BAC32Z1
(BAC net)

Intesis
BY HMS NETWORKS



FG-RTR-MBS32Z1
(MODBUS®)

Routing between BaCnet® MS/TP and BaCnet® IP networks

- Routing between BaCnet® MS/TP and BaCnet® IP networks
- Routing between MODBUS® RTU and MODBUS® TCP networks

Installation example

[BaCnet® type]

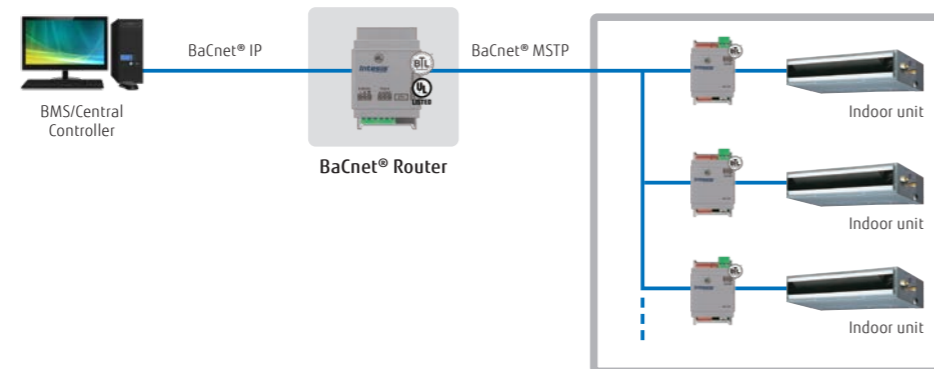

[MODBUS® type]

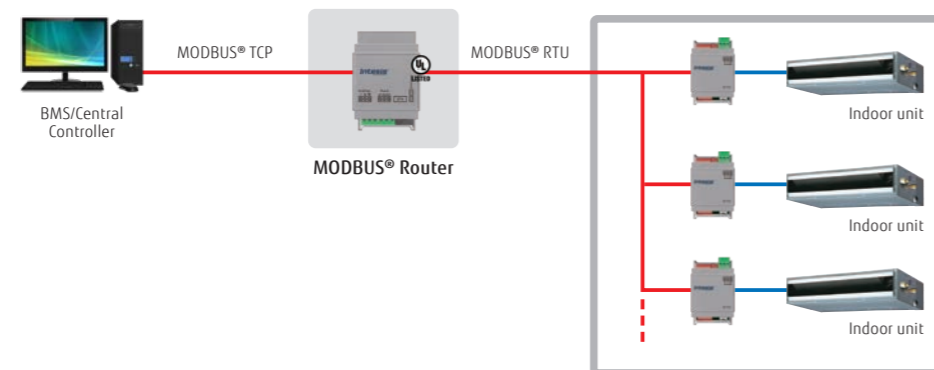

Specifications

Model name	FG-RTR-BAC32Z1 (MS/TP to IP)	FG-RTR-MBS32Z1 (RTU to TCP)
Number of routable devices (max.)	32	32
Power supply	9 to 36 V DC, Max.: 140 mA or 24 V AC 50/60 Hz, Max.: 127 mA	9 to 36 V DC, Max.: 140 mA or 24 V AC 50/60 Hz, Max.: 127 mA
Power consumption (W)	1.7	1.7
Dimensions (H × W × D) (mm)	93 × 53 × 58	93 × 53 × 58
Weight (g)	150	150

BACnet®/MODBUS® Cloud Device

FG-CLD-BMG4Z1 / FG-CLD-BMG8Z1 / FG-CLD-BMG16Z1 / FG-CLD-BMG32Z1



Intesis
BY HMS NETWORKS



FG-CLD-BMG4Z1/8/16/32Z1

- The most powerful configuration tool common to all BACnet® gateways provides the system integrators with the power to configure and monitor their systems in an easy and reliable manner.
- A simple, easy-to-use description for the ST Cloud Web and App User Interface, with all widgets customizable to the user's needs, enabling system integrators to easily offer the best user experience to customers who are in control of their BaCnet® or MODBUS® devices.

Installation example

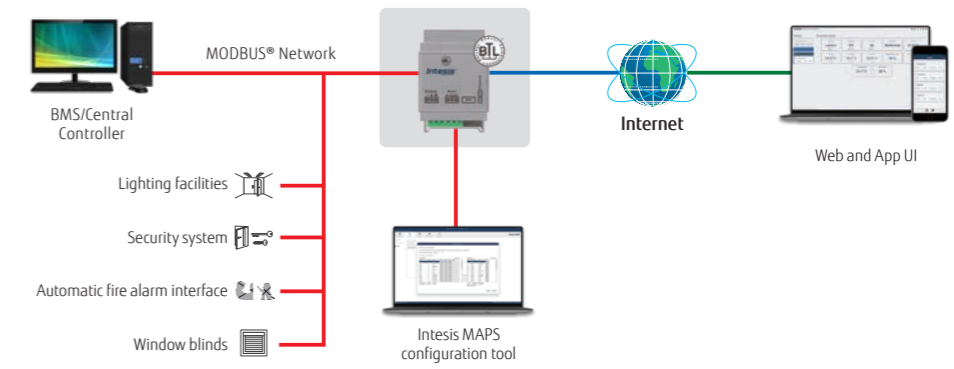

*BMS: Building Management System

Gateway features

- BaCnet® IP/MSTP or MODBUS® TCP/RTU connectivity
- Up to 32 devices can be connected to each gateway.
- Up to 12 widgets per device
- Easy device configuration with Intesis MAPS

Next-generation services

- Industrial-grade connectivity now for building automation
- Fast and scalable real-time edge connectivity over HMS HubTM
- Full data control and protection
- Secure and remote updates during the application lifetime

System Features

- Monitor and control all devices in an intuitive way
- Comes with a native iOS and Android app and a web interface
- Create scenes and interact with multiple concurrent devices
- Calendar that shows the daily planned installation commands
- Notifications keep you updated about system status
- Device sharing and usage permissions management
- Multiple site management from a common dashboard

Specifications

Model name	FG-CLD-BMG4Z1	FG-CLD-BMG8Z1	FG-CLD-BMG16Z1	FG-CLD-BMG32Z1
Number of connectable BaCnet® (IP/MSTP) or MODBUS® (TCP/RTU) devices	4	8	16	32
Power supply	9 to 24 V DC, 50/60Hz	9 to 24 V DC, 50/60Hz	9 to 24 V DC, 50/60Hz	9 to 24 V DC, 50/60Hz
Power consumption (W)	1.7	1.7	1.7	1.7
Dimensions (H × W × D) (mm)	93 × 53 × 58	93 × 53 × 58	93 × 53 × 58	93 × 53 × 58
Weight (g)	150	150	150	150

KNX® converter for indoor unit

UTY-VKSX



Up to
1 indoor unit

KNX® Converter enables individual control of an indoor unit.

- The new KNX® converter connects a central or home controller and a Fujitsu General indoor unit.
- Compact and lightweight design

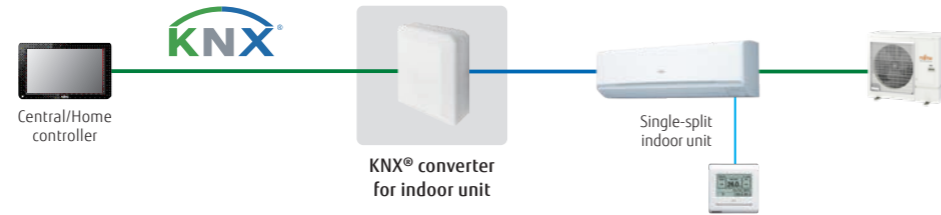

KNX® converter for VRF

UTY-VKGX / FG-TL-KNX16Z1

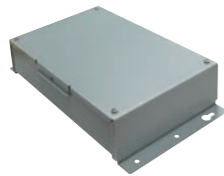

UTY-VKGX

Up to
100 outdoor units
Up to
128 indoor units



FG-TL-KNX16Z1

Up to
16 indoor units
Up to
16 outdoor units

KNX® converter enables centralized control of a system.

- KNX® converter connects a central or home controller and a Fujitsu General VRF system.
- Up to 128 indoor units and 100 outdoor units can be connected to a single KNX® converter. (UTY-VKGX)

Installation example

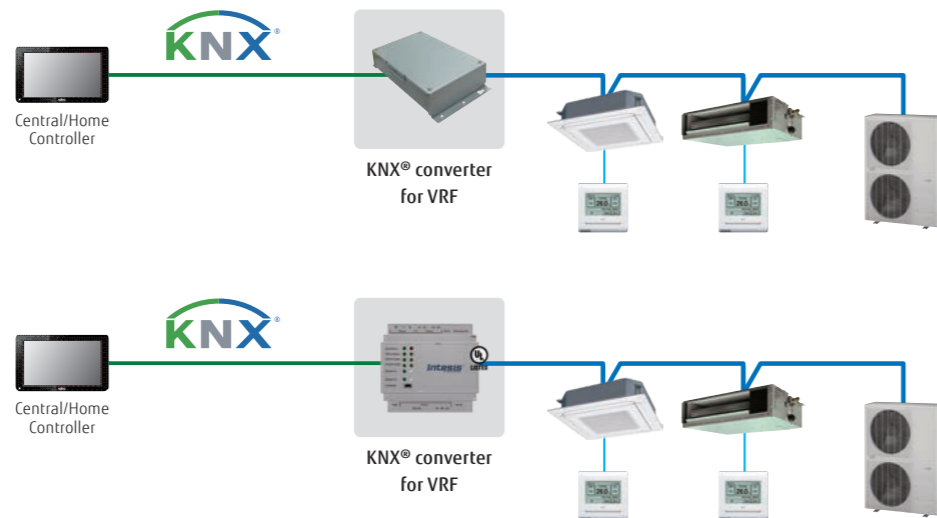

Specifications

Model name	UTY-VKSX	UTY-VKGX	FG-TL-KNX16Z1
Power supply	12 V DC	Single phase ~220 to 240 V 50/60 Hz	9 to 36 V DC, Max.: 140 mA or 24 V AC 50/60 Hz, Max.: 127 mA.*
Input power (W)	0.6	1.5	1.6
Dimensions (H × W × D) (mm)	140 × 117 × 43	54 × 260 × 150	90 × 88 × 56
Weight (g)	215	1,200	340

*24 V DC power supply is recommended.

KNX® interface

FG-RC-KNX1Z1 / FG-AC-KNX1Z1 / FG-IR-KNX1Z1



Intesis®



FG-RC-KNX1Z1
(3-wire RC-line type)

Intesis®



FG-AC-KNX1Z1
(CN connector type)

Intesis®



FG-IR-KNX1Z1
(IR type)

Up to
1 indoor unit

The KNX® interface enables air conditioners to be fully integrated into a KNX® network system.

- Simple installation due to small and compact size.
- No separate external power supply required (only KNX® bus power required)

Installation example

[3-wire RC-line type/CN connector type]

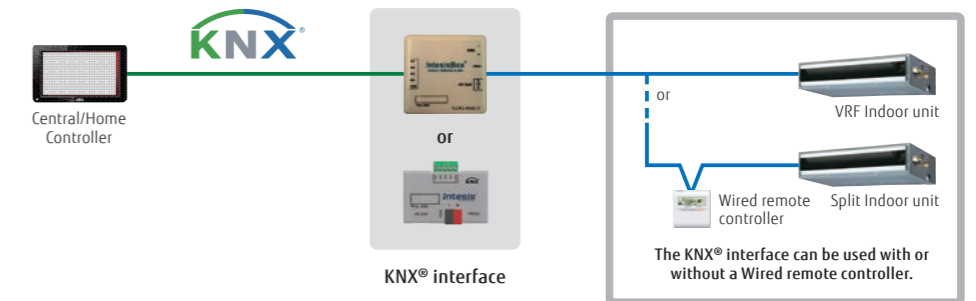

[IR type] Connection to wall-mounted type

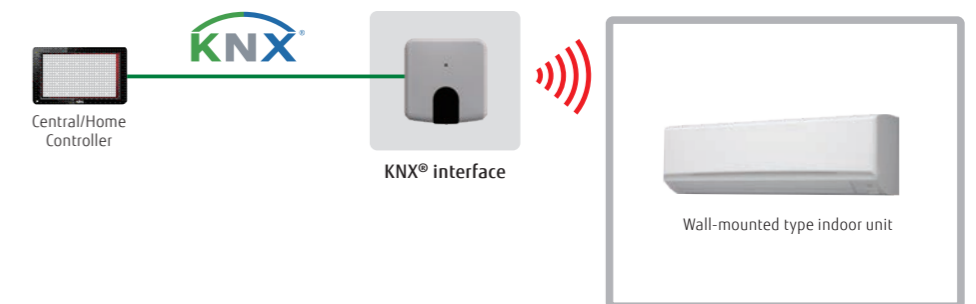

[IR type] Connection to a product other than wall-mounted type

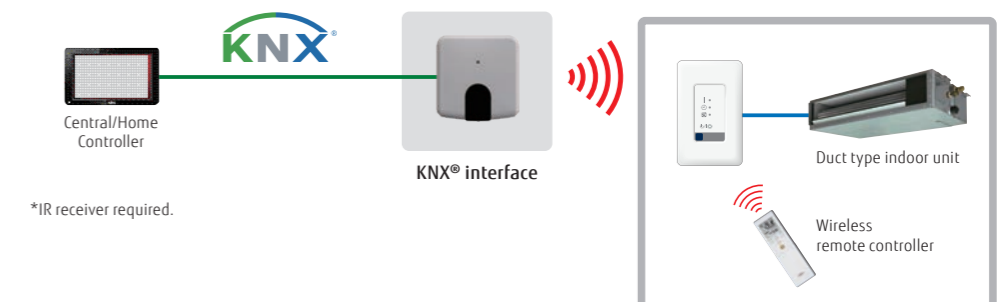

Specifications

Model name	FG-RC-KNX1Z1 (3-wire RC-line type)	FG-AC-KNX1Z1 (CN connector type)	FG-IR-KNX1Z1 (IR type)
Number of controllable groups	1	1	1
Dimensions (H × W × D) (mm)	70 × 70 × 28	45 × 59 × 21	81 × 78 × 28
Weight (g)	70	35	76

Network converter for single-split type

UTY-VTGX / UTY-VTGXV



UTY-VTGX
DC power supply type

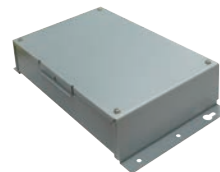

UTY-VTGXV
AC power supply type

Up to
16 single indoor units
Up to
1 group
Up to
100 Network Converters

- A network converter is required when connecting a single-split system to a VRF network system.
- Compact and lightweight design
- Connectable to both nonpolar 2-core and polar 3-core remote controllers

Installation example

- A 1-remote-controller type and a 2-remote-controller type are available.
- Power supply (220 to 240 V AC, 50/60 Hz) is required for the 2-remote-controllers type.

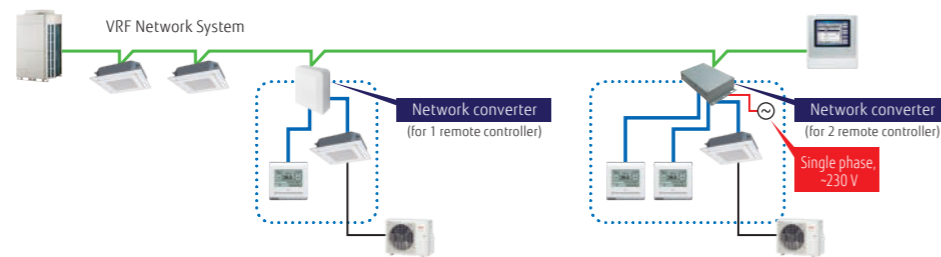

- Both nonpolar 2-core and polar 3-core type Wired remote controllers can be connected.

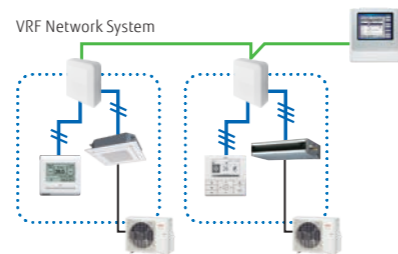

- Central control can be provided for single-split systems. (Up to 100 network converters can be connected in a VRF network system)

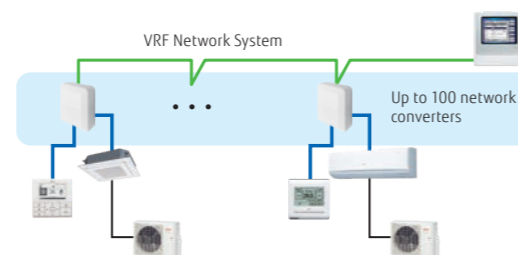

Specifications

Model name	UTY-VTGX		UTY-VTGXV
	Power supply	Polar 3-core 12 V DC	Nonpolar 2-core DC 12 V
Input power (W)	Max. 1.2 W		Max. 3
Dimensions (H × W × D) (mm)	140 × 117 × 43		54 × 260 × 150
Weight (g)	250		1,100

Network converter for LONWORKS™

UTY-VLGX

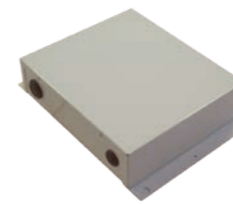

Up to
4 units to BMS
Up to
100 outdoor units
Up to
128 indoor units

- Connects the VRF network system to a LONWORKS™ open network to manage small and mid-sized BMS and VRF network system.
- The UTY-VLGX enables centralized monitoring and control of VRF network system from a BMS via a LONWORKS™ interface.
- Up to 128 Indoor units can be connected to one network converter for LONWORKS™

Installation example

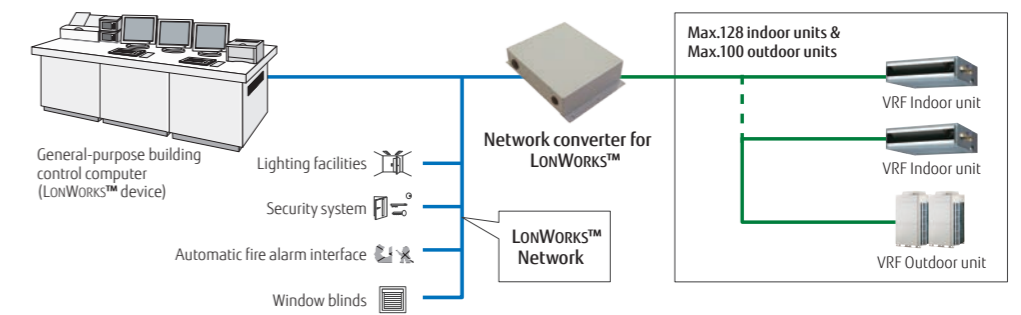

Specifications

Model name	UTY-VLGX
Power supply	Single phase ~208 to 240 V 50/60 Hz
Power consumption (W)	4.5
Dimensions (H × W × D) (mm)	67 × 288 × 211
Weight (g)	1,500

Transmission specifications (BMS side)

Transmission speed	78 kbps
Transceiver	FT-X1 (available from Echelon® Corporation)
Transmission line form	Free topology
Terminal resistor	None (converter to be attached at the terminal of a network)

External switch controller

UTY-TERX



Up to
1 group

Air conditioner switching can be controlled by connecting this external switch controller to other sensor switches.

- In combination with a commercially available card-key switch or other sensors, this External switch controller enables the control of ON/OFF, room temperature, and fan speed of connected air conditioners as well as master control functions. This makes this product an ideal choice for use in hotel rooms.
- Card key or other sensor switches are locally available.
- The set temperature can be specified at two points each for cooling and heating operations (4 points in total).

Installation example

Occupancy sensor monitors the movement of a person in a room. When it detects that the person has left the room, it switches the air conditioner to low-capacity mode. When a person returns to the room, the air conditioner returns to the previous operation mode.

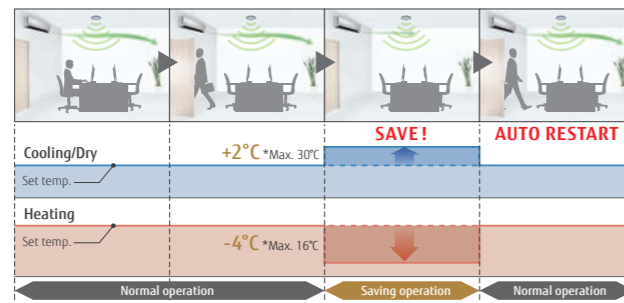

Occupancy sensor equipment needs to be purchased separately.
Occupancy sensor is not mounted on an External switch controller.

Signal amplifier

UTY-VSGXZ1

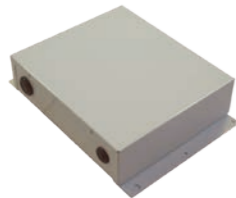

- The transmission line can be extended up to 3,600 m using multiple Signal amplifiers.
- Up to 8 Signal amplifiers can be added in a VRF network system.
- A Signal amplifier is required.
 - (1) When the total wiring length of the transmission line exceeds 500 m.
 - (2) When the total number of units on the transmission line exceeds 64.

Installation example

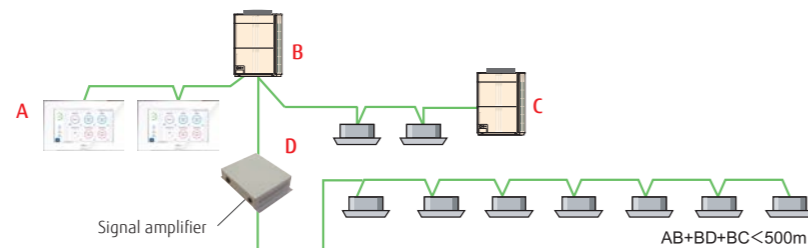

Specifications

Model name	UTY-VSGXZ1	UTY-TERX
Power supply	Single phase ~208 to 240 V 50/60 Hz	6.5 to 16 V DC
Power consumption (W)	4.5	-
Dimensions (H × W × D) (mm)	67 × 288 × 211	140 × 117 × 43
Weight (g)	1,500	250

12 V DC supplied by an indoor unit



Controller system list (available) for Split/Multi-split

Controller Options/Accessories:



Type	Refrigerant	Indoor unit														Indoor unit				Outdoor unit					
		Wall-mounted			Cassette		Duct		Duct			BIG		Floor	Ceiling	Multi-split			Single phase						
		Designer Series	Standard Series		ECO Series	Compact 4-way flow Series	Circular flow Series	Slim	Medium static pressure (High Efficiency & Comfort)	Medium static pressure (Compact)	Medium static pressure (Standard)	High static pressure					Wall-mounted	Compact cassette	Mini duct	Slim duct	5/6-unit multi-split				
	ASYG 07/09/12/14 KGTF, KGTE	ASYG 07/09/12/14 KETF, KETF-B, KETE, KETE-B	ASYG 07/09/12/14 KMCF, KMCE	ASYG 18/24KMTE	ASYH 30/36KMTB	ASYG 07/09/12 KPCE	AUXG 09/12/14/18/22/24 KVLA	AUXG 18/22/24/30/36/45/54 KRLB	ARXG 09/12/14/18 KLLAP	ARXH 22/24/30/36/45/54 KMTAP	ARXG 12/14/18/22/24/30/36/45/54 KHTAP	ARXG22KMLB, ARXG 24/30/36/45 KMLA	ARXG 45/54KHTB	ARYG 60LHTA	ARYG 72/90LHTA	ACYG 09/12/14 KVCA	ABYG 18/22/24/30/36/45/54 KR1A	ASYG 22KMTE	AUXG 07KVLA	ARXG 07/09/12/14/18 KSLAP	ARXG 07KLLAP	AOYG36KBTA5			
																							AOYG45LBLA6		
Wired remote controller		● UTY-RNRYZ5+ UTY-TWRXZ2			● UTY-RNRYZ5		● UTY-RNRYZ5		● UTY-RNRYZ5		● UTY-RNRYZ5		● UTY-RNRYZ5	● UTY-RNRYZ5+ UTY-TWRXZ3	● UTY-RNRYZ5	● UTY-RNRYZ5+ UTY-TWRXZ2	● UTY-RNRYZ5	● UTY-RNRYZ5	● UTY-RNRYZ5	● UTY-RNRYZ5	● UTY-RNRYZ5	● UTY-RNRYZ5	● UTY-RNRYZ5	● UTY-RNRYZ5	● UTY-RNRYZ5
		● UTY-RLRY+ UTY-TWRXZ2			● UTY-RLRY		● UTY-RLRY		● UTY-RLRY		● UTY-RLRY		● UTY-RLRY	● UTY-RLRY+ UTY-TWRXZ3	● UTY-RLRY	● UTY-RLRY+ UTY-TWRXZ2	● UTY-RLRY	● UTY-RLRY	● UTY-RLRY	● UTY-RLRY	● UTY-RLRY	● UTY-RLRY	● UTY-RLRY	● UTY-RLRY	● UTY-RLRY
		● UTY-RCRYZ1+ UTY-TWRXZ2			● UTY-RCRYZ1		● UTY-RCRYZ1		● UTY-RCRYZ1		● UTY-RCRYZ1		● UTY-RCRYZ1	● UTY-RCRYZ1+ UTY-TWRXZ3	● UTY-RCRYZ1	● UTY-RCRYZ1+ UTY-TWRXZ2	● UTY-RCRYZ1	● UTY-RCRYZ1	● UTY-RCRYZ1	● UTY-RCRYZ1	● UTY-RCRYZ1	● UTY-RCRYZ1	● UTY-RCRYZ1	● UTY-RCRYZ1	● UTY-RCRYZ1
					● UTY-RVNYM		● UTY-RVNYM		● UTY-RVNYM		● UTY-RVNYM		● UTY-RVNYM	● UTY-RVNYM	● UTY-RVNYM	● UTY-RVNYM	● UTY-RVNYM	● UTY-RVNYM	● UTY-RVNYM	● UTY-RVNYM	● UTY-RVNYM	● UTY-RVNYM	● UTY-RVNYM	● UTY-RVNYM	● UTY-RVNYM
					● UTY-RNNYM		● UTY-RNNYM		● UTY-RNNYM		● UTY-RNNYM		● UTY-RNNYM	● UTY-RNNYM	● UTY-RNNYM	● UTY-RNNYM	● UTY-RNNYM	● UTY-RNNYM	● UTY-RNNYM	● UTY-RNNYM	● UTY-RNNYM	● UTY-RNNYM	● UTY-RNNYM	● UTY-RNNYM	● UTY-RNNYM
Simple remote controller	 Nonpolar 2-core type	 Polar 3-core type	● UTY-RSRY UTY-RHRY+ UTY-TWRXZ2			● UTY-RSRY, UTY-RHRY, UTY-RSNYM		● UTY-RSRY UTY-RHRY		● UTY-RSRY, UTY-RHRY, UTY-RSNYM		● UTY-RSRY UTY-RHRY	● UTY-RSRY	● UTY-RSRY UTY-RHRY	● UTY-RSRY	● UTY-RSRY UTY-RHRY+ UTY-TWRXZ3	● UTY-RSRY UTY-RHRY	● UTY-RSRY UTY-RHRY+ UTY-TWRXZ2	● UTY-RSRY UTY-RHRY	● UTY-RSRY UTY-RHRY	● UTY-RSRY UTY-RHRY	● UTY-RSRY UTY-RHRY	● UTY-RSRY UTY-RHRY	● UTY-RSRY UTY-RHRY	● UTY-RSRY UTY-RHRY
Home central remote controller																							● UTY-DMMYM1*3 (KBTA5) ● UTY-DMMYM*3 (LBLA6)		
Wireless remote controller					● UTY-LNTY																	● UTY-LNTY			
IR receiver unit with Wireless remote controller		For Duct type											● UTY-LRHYM												
		For Duct type	For Cassette type	For Ceiling type			● UTY-LBTC		● UTY-LBTYM		● UTY-LBTYM			● UTY-LBTYM		● UTY-LBTYM		● UTY-LBTYM				● UTY-LBTYM			

*1: Available only when the WLAN adapter (UY-TFSXF2) is removed. *2 Available only when the WLAN adapter (UY-TFSXZ1) is removed. *3 Consult your dealer for conditions of use.

Controller system list (available) for Split/Multi-split

Controller Options/Accessories:



Type	Refrigerant	Indoor unit												Indoor unit				Multi-split													
		Wall-mounted			Cassette			Duct			Duct			Floor	Ceiling	Wall-mounted	Compact cassette	Mini duct	Slim duct												
		Designer Series	Standard Series	ECO Series	Compact 4-way flow Series	Circular flow Series	Slim	Medium static pressure (High Efficiency & Comfort)	Medium static pressure (Compact)	Medium static pressure (Standard)	High static pressure	BIG			ASYG 22KMTE	AUXG 07KVLA	ARXG 07/09/12/14/18 KSLAP	ARXG 07KLLAP													
		ASYG 07/09/12/14 KGT, KGTB	ASYG 07/09/12/14 KET, KET-B, KETE, KETE-B	ASYG 07/09/12/14 KMCF, KMCE	ASYG 18/24KMTE	ASYG 30/36KMTE	ASYG 07/09/12 KPCE	ASYG 18/24KLCA	AUXG 09/12/14/18/22/24 KVLA	AUXG 18/22/24/30/36/45/54 KRLB	ARXG 09/12/14/18 KLLAP	ARXH 22/24/30/36/45/54 KMTP	ARXG 12/14/18/22/24/30/36/45/54 KHTAP	ARXG22KMLB, ARXG 24/30/36/45 KMLA	ARXG 45/54KHTB		ARYG 60LHTA	ARYG 72/90LHTA	AGYG 09/12/14 KVCA	ABYG 18/22/24/30/36/45/54 KRVA	ASYG 22KMTE	AUXG 07KVLA	ARXG 07/09/12/14/18 KSLAP	ARXG 07KLLAP							
Interfaces		• UTY-VMSX			• UTY-VMSX			• UTY-VMSX			• UTY-VMSX			• UTY-VMSX			• UTY-VMSX*2			• UTY-VMSX			• UTY-VMSX*1			• UTY-VMSX					
		• FG-AC-MBS1Z1			• FG-RC-MBS1Z1 • FG-AC-MBS1Z1			• FG-RC-MBS1Z1 • FG-AC-MBS1Z1			• FG-AC-MBS1Z1			• FG-RC-MBS1Z1			• FG-RC-MBS1Z1 • FG-AC-MBS1Z1			• FG-AC-MBS1Z1			• FG-RC-MBS1Z1 • FG-AC-MBS1Z1			• FG-RC-MBS1Z1 • FG-AC-MBS1Z1					
		• FG-IR-BMG1Z1			• FG-IR-BMG1Z1+ • UTY-LBTYC			• FG-IR-BMG1Z1+ • UTY-LBTYM			• FG-IR-BMG1Z1+ • UTY-LBTYM			• FG-IR-BMG1Z1+ • UTY-LRHYM			• FG-IR-BMG1Z1			• FG-IR-BMG1Z1+ • UTY-LBTYH			• FG-IR-BMG1Z1			• FG-IR-BMG1Z1+ • UTY-LBTYM					
		• UTY-VKSX			• UTY-VKSX			• UTY-VKSX			• UTY-VKSX			• UTY-VKSX			• UTY-VKSX*2			• UTY-VKSX			• UTY-VKSX*1			• UTY-VKSX					
		• FG-AC-KNX1Z1			• FG-RC-KNX1Z1 • FG-AC-KNX1Z1			• FG-RC-KNX1Z1 • FG-AC-KNX1Z1			• FG-AC-KNX1Z1			• FG-RC-KNX1Z1			• FG-RC-KNX1Z1 • FG-AC-KNX1Z1			• FG-AC-KNX1Z1			• FG-RC-KNX1Z1 • FG-AC-KNX1Z1			• FG-RC-KNX1Z1 • FG-AC-KNX1Z1					
		• FG-IR-KNX1Z1			• FG-IR-KNX1Z1+ • UTY-LBTYC			• FG-IR-KNX1Z1+ • UTY-LBTYM			• FG-IR-KNX1Z1+ • UTY-LBTYM			• FG-AC-KNX1Z1+ • UTY-LBTYM			• FG-IR-KNX1Z1+ • UTY-LRHYM			• FG-IR-KNX1Z1			• FG-IR-KNX1Z1+ • UTY-LBTYH			• FG-IR-KNX1Z1			• FG-IR-KNX1Z1+ • UTY-LBTYM		
		• UTY-TFSX1Z1			• UTY-TFSX1Z1			• UTY-TFSX1Z1			• UTY-TFSX1Z1			• UTY-TFSX1Z1			• UTY-TFSX1Z1			• UTY-TFSX1Z1			• UTY-TFSX1Z1			• UTY-TFSX1Z1					
		• UTY-TFSX1Z1			• UTY-TFSX1Z1			• UTY-TFSX1Z1			• UTY-TFSX1Z1			• UTY-TFSX1Z1			• UTY-TFSX1Z1			• UTY-TFSX1Z1			• UTY-TFSX1Z1			• UTY-TFSX1Z1					
		• Accessory (KGT, KET, KET-B, KMCF) • UTY-TFSXH3, UTY-TFSXF2 (KGT, KETE, KETE-B, KMCE)			• UTY-TFSXH3 • UTY-TFSXF2																		• UTY-TFSXH3 • UTY-TFSXF2								
		• FG-AC-WIF1Z1			• FG-RC-WIF1Z2 • FG-AC-WIF1Z1			• FG-RC-WIF1Z2 • FG-AC-WIF1Z1			• FG-AC-WIF1Z1			• FG-RC-WIF1Z2			• FG-RC-WIF1Z2 • FG-AC-WIF1Z1			• FG-AC-WIF1Z1			• FG-RC-WIF1Z2 • FG-AC-WIF1Z1			• FG-RC-WIF1Z2 • FG-AC-WIF1Z1					
	• FG-IR-WIF1Z1			• FG-IR-WIF1Z1+ • UTY-LBTYC			• FG-IR-WIF1Z1+ • UTY-LBTYM			• FG-IR-WIF1Z1+ • UTY-LBTYM			• FG-IR-WIF1Z1+ • UTY-LRHYM			• FG-IR-WIF1Z1			• FG-IR-WIF1Z1+ • UTY-LBTYH			• FG-IR-WIF1Z1			• FG-IR-WIF1Z1+ • UTY-LBTYM						
	• FG-AC-WMP1Z1			• FG-RC-WMP1Z1 • FG-AC-WMP1Z1			• FG-RC-WMP1Z1 • FG-AC-WMP1Z1			• FG-AC-WMP1Z1			• FG-RC-WMP1Z1			• FG-RC-WMP1Z1 • FG-AC-WMP1Z1			• FG-AC-WMP1Z1			• FG-RC-WMP1Z1 • FG-AC-WMP1Z1			• FG-RC-WMP1Z1 • FG-AC-WMP1Z1						
	• FG-IR-WMP1Z1			• FG-IR-WMP1Z1+ • UTY-LBTYC			• FG-IR-WMP1Z1+ • UTY-LBTYM			• FG-IR-WMP1Z1+ • UTY-LBTYM			• FG-IR-WMP1Z1+ • UTY-LRHYM			• FG-IR-WMP1Z1			• FG-IR-WMP1Z1+ • UTY-LBTYH			• FG-IR-WMP1Z1			• FG-IR-WMP1Z1+ • UTY-LBTYM						
External switch controller		• UTY-TERX+UTY-TWRXZ2			• UTY-TERX			• UTY-TERX			• UTY-TERX			• UTY-TERX			• UTY-TERX+ • UTY-TWRXZ3			• UTY-TERX			• UTY-TERX+ • UTY-TWRXZ2			• UTY-TERX					
Network converter for single-split type		• UTY-VTGX+UTY-TWRXZ2 • UTY-VTGXV+UTY-TWRXZ2			• UTY-VTGX • UTY-VTGXV			• UTY-VTGX • UTY-VTGXV			• UTY-VTGX • UTY-VTGXV			• UTY-VTGX • UTY-VTGXV			• UTY-VTGX+ • UTY-TWRXZ3			• UTY-VTGX • UTY-VTGXV			• UTY-VTGX+ • UTY-TWRXZ2 or • UTY-VTGXV+ • UTY-TWRXZ2			• UTY-VTGX • UTY-VTGXV					

*1: Available only when the WLAN adapter (UY-TFSXF2) is removed. *2: Available only when the WLAN adapter (UY-TFSX1Z1) is removed.
*3: For compatibility of the new WLAN adapters with the indoor units which are not listed in this catalogue, please refer to page C-019.

Controller System List (available) for VRF

Controller Options:



Type	Refrigerant	Indoor unit										Indoor unit									
		Cassette		Slim type		Large type		Duct			Duct		Floor		Ceiling/ Floor	Ceiling	Wall-mounted				
		One-way flow	3D flow	Compact Grid type/ Standard type	Circular flow		Mini (With drain pump)	Low static pressure duct		High Efficiency	Normal	High static pressure	Normal	-	external EEV	-	-	-	external EEV	-	external EEV
	AUXV 004/007/009/ 012/014/018/ 024GLEH	AUXS 018/024 GLEH	AUXB 004/007/009/ 012/014/018/ 024GLEH	AUXM 018/024/030 GLEH	AUXK 018/024/030/ 034/036/045/ 054GLEH	ARXK 004/007/009/ 012/014/018/ 024GLGH	ARXD 04GALH	ARXD 007/009/012/ 014/018/024 GLEH	ARXP 018/030 GLFH	ARXA 024/030/ 036/045 GLEH	ARXC 036/045/060/ 072/090/096 GTEH	AGYA 004/007/ 009/012/014 GCGH	AGYE 004/007/ 009/012/014 GCEH	ABYA 012/014/ 018/024 GTEH	ABYA 030/036/ 045/054 GTEH	ASVA 004/007/009 GCGH	ASVE 004/007/009 GCEH	ASVA 012/014GCGH	ASVE 012/014GCEH	ASVA 18/24GBCH	ASVA 030/034GTEH
Interfacing		UTY-ABGXZ1, UTY-VBGX																			
		FG-AC-BAC1Z1										FG-AC-BAC1Z1									
BACnet gateway		FG-AC-BAC1Z1										FG-AC-BAC1Z1									
		FG-IR-BMG1Z1+ UTY-TRHX	FG-IR-BMG1Z1	FG-IR-BMG1Z1+ UTY-LBHXD	FG-IR-BMG1Z1+ UTY-TRHX	FG-IR-BMG1Z1+ UTB-YWC	FG-IR-BMG1Z1+ UTY-TRHX					FG-IR-BMG1Z1+ UTY-TRHX	FG-IR-BMG1Z1								
Network converter for LonWorks™		UTY-VLGX																			
MODBUS® Converter		UTY-VMSX																			
		UTY-VMGX FG-TL-MBS16Z1										UTY-VMGX FG-TL-MBS16Z1									
MODBUS® interface		FG-AC-MBS1Z1										FG-RC-MBS1Z1	FG-AC-MBS1Z1				FG-AC-MBS1Z1	FG-RC-MBS1Z1	FG-AC-MBS1Z1		
		FG-IR-BMG1Z1+ UTY-TRHX	FG-IR-BMG1Z1	FG-IR-BMG1Z1+ UTY-LBHXD	FG-IR-BMG1Z1+ UTY-TRHX	FG-IR-BMG1Z1+ UTB-YWC	FG-IR-BMG1Z1+ UTY-TRHX					FG-IR-BMG1Z1+ UTY-TRHX	FG-IR-BMG1Z1								
KNX® converter		UTY-VKSX																			
		UTY-VKGX FG-TL-KNX16Z1										UTY-VKGX FG-TL-KNX16Z1									
KNX® interface		FG-AC-KNX1Z1										FG-RC-KNX1Z1	FG-AC-KNX1Z1				FG-AC-KNX1Z1	FG-RC-KNX1Z1	FG-AC-KNX1Z1		
		FG-IR-KNX1Z1+ UTY-TRHX	FG-IR-KNX1Z1	FG-IR-KNX1Z1+ UTY-LBHXD	FG-IR-KNX1Z1+ UTY-TRHX	FG-IR-KNX1Z1+ UTB-YWC	FG-IR-KNX1Z1+ UTY-TRHX					FG-IR-KNX1Z1+ UTY-TRHX	FG-IR-KNX1Z1								
WLAN adapter		UTY-TFSXJ3 UTY-TFSXZ1										UTY-TFSXJ3 UTY-TFSXZ1 (007-024)		UTY-TFSXJ3 UTY-TFSXZ1				UTY-TFSXJ3 UTY-TFSXZ1		UTY-TFSXJ3 UTY-TFSXZ1	
		FG-AC-WIF1Z1										FG-RC-WIF1Z2	FG-AC-WIF1Z1				FG-AC-WIF1Z1		FG-RC-WIF1Z2	FG-AC-WIF1Z1	
		FG-IR-WIF1Z1+ UTY-TRHX	FG-IR-WIF1Z1	FG-IR-WIF1Z1+ UTY-LBHXD	FG-IR-WIF1Z1+ UTY-TRHX	FG-IR-WIF1Z1+ UTB-YWC	FG-IR-WIF1Z1+ UTY-TRHX					FG-IR-WIF1Z1+ UTY-TRHX	FG-IR-WIF1Z1								
		FG-AC-WMP1Z1										FG-RC-WMP1Z1	FG-AC-WMP1Z1				FG-AC-WMP1Z1		FG-RC-WMP1Z1	FG-AC-WMP1Z1	
		FG-IR-WMP1Z1+ UTY-TRHX	FG-IR-WMP1Z1	FG-IR-WMP1Z1+ UTY-LBHXD	FG-IR-WMP1Z1+ UTY-TRHX	FG-IR-WMP1Z1+ UTB-YWC	FG-IR-WMP1Z1+ UTY-TRHX					FG-IR-WMP1Z1+ UTY-TRHX	FG-IR-WMP1Z1								
External switch controller		UTY-TERX																			

*1: For compatibility of the new WLAN adapters with the indoor units which are not listed in this catalogue, please refer to page C-019.

Optional parts overview

For Split & Multi-split, VRF

A variety of optional parts are available to enable installation of the selected indoor unit properly according to the environment.

Optional Parts For Cassette



Occupancy sensor kit
A built-in thermo sensor monitors and controls room temperature accurately.



Cassette grille
A lineup of cassette grilles that match a variety of interiors. A grid ceiling-type cassette grille has been added to the lineup.

For Compact cassette For Cassette type
For Cassette type Circular flow



Silver ion filter
The Silver ion filter helps to keep indoor air free from viruses, bacteria and molds.*



Fresh air intake kit
Fresh air can be taken in by a fan connected to an external control unit.

For Compact cassette For Circular flow cassette



Insulation kit for high humidity
Insulation kit for high humidity is used when the installation location is in a high humidity environment.



Air outlet shutter plate
Airflow directions can be changed to 3 directions using the Air outlet shutter plate depending on the installation location.

For Compact cassette For Circular flow cassette



Wide Panel
When a cassette type is installed in a narrow space in the ceiling, the wide panel fills in that space.

Indoor unit 950
Panel 600 (mm)
600



Panel spacer
If the ceiling space is tight and the main body protrudes from the ceiling surface, a panel spacer can be used as a decorative trim.

242 mm
Panel spacer

Optional Parts For V-IV



Pressure sensor kit
The height difference of the pressure sensor kit can be extended up to 110 m.

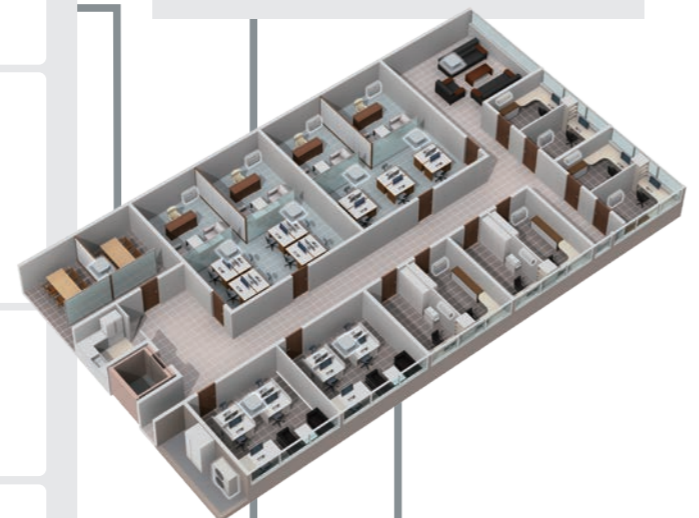

Optional Parts For Floor

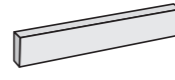

Half concealed kit
Used to half conceal a floor type indoor unit in the wall.



Silver ion filter
The Silver ion filter helps to keep indoor air free from viruses, bacteria and molds.*



Optional Parts For Duct & Ceiling



Auto louver grille kit
The optional clean-looking flat Auto louver grille blends into any interior and provides a comfortable airflow.



Remote sensor unit
The remote sensor provides additional convenience.

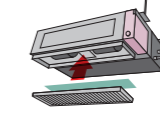

Silver ion filter
The Silver ion filter helps to keep indoor air free from viruses, bacteria and molds.*



Long-life filter
Captures grit and dust. Long-life design with consideration of running costs.



Flange
Flanges are used when connecting a medium static pressure duct type and a ceiling type with air intake and exhaust ducts.



Drain pump unit
Drains water that has accumulated during operation.

Connection Parts

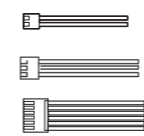

External connect kit & set
Connect the printed circuit board (PCB) to external devices.



Communication kit
Required for a wall-mounted type when the External connect kit set or a Wired remote controller is connected to the indoor unit.

For wall-mounted type



External input and output PCB
For Wall-mounted, Duct, or Cassette type, these parts are required when the external input and output function is used.

For wall-mounted type



External power supply unit
The External power supply unit protects the increment in the system even if the power supply for some of the indoor units is shut down.



External input and output PCB box & bracket
Box and bracket for installing the External input and output PCB.

For Duct type and Cassette type

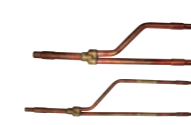

Connection Units
Connection units are available to separate the pipes when connecting multiple indoor units in a Multi-split type or VRF system.

*Not a result of experiments in an actual use environment. Silver ion filter inhibits activity or growth of microorganism, but do not prevent infection.

Silver Ion Filter

UTR-FA16-5 / UTR-FA13-3 / UTR-FA03-5 / UTD-HFAA / UTD-HFRA / UTD-HFTA / UTD-HFTB / UTD-HFTC / UTD-HFNC / UTD-HFNB / UTD-HFNA / UTD-HFND / UTD-HFKB / UTD-HFKA



For Wall mounted / Floor
UTR-FA16-5 / UTR-FA13-3
UTR-FA03-5

For Cassette
UTD-HFAA / UTD-HFRA

For Duct
UTD-HFTA / UTD-HFTB
UTD-HFTC / UTD-HFNC
UTD-HFNB / UTD-HFNA
UTD-HFND / UTD-HFKB
UTD-HFKA

The Silver ion filter helps to keep indoor air free from viruses, bacteria and molds.

(Not a result of experiments in an actual use environment. Silver ion filter inhibits activity or growth of microorganism, but do not prevent infection.)

The silver ion filter inhibits the activities of viruses*1, bacteria*2 and molds*3 trapped on the filter.

(Only effective when the microorganism is trapped on the filter with dust or droplet)

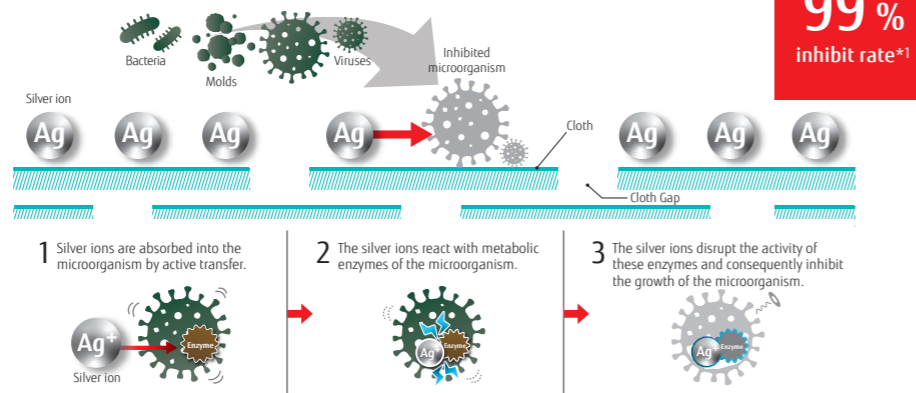

*1 [Testing organization] Kitasato Research Center for Environmental Science [Test Report] No. 2020_0408 [Test virus] Escherichia coli phage Qbeta NBRC 20012 (1 type) [Test Method] Based on the antiviral test method for textile products (JIS L 1922) [Test results] Inhibited by at least 99% in 24 hours. Not tested to prevent transmission of SARS-CoV-2.
*2 [Testing organization] Kitasato Research Center for Environmental Science [Test Report] No. 2020_0409 [Test bacteria] Escherichia coli NBRC 3972 (1 type) [Test Method] Based on the determination of antibacterial activity and efficacy of textile products (JIS L 1902) [Test results] The growth of the test bacteria was inhibited by 24 hours testing
*3 [Testing organization] Kitasato Research Center for Environmental Science [Test Report] No. 2020_0410 [Test fungi] Aspergillus Niger NBRC 105649 and other fungi (3 types) [Test Method] Based on the test for fungus resistance (JIS Z 2911) [Test results] The growth of the fungus was inhibited by 28 days testing

The filter is easily removable* and hand-washable.

(*Wall mounted and floor models only)



*4 Hand-washing or vacuuming by 3 months is recommended. Cleaning frequency varies depending on the environment of use.

Specifications

Model name	For Wall mounted / Floor			for Cassette		
	UTR-FA16-5	UTR-FA13-3	UTR-FA03-5	UTD-HFAA	UTD-HFRA	
Net Dimension (H x W x D)	mm	35 x 210 x 6	50 x 364 x 6	43 x 272 x 6	350 x 125 x 6	550 x 136 x 6
Weight	g	2	2	2	7	23
Quantity		2	2	2	1	1

Model name	for Duct									
	UTD-HFTA	UTD-HFTB	UTD-HFTC	UTD-HFNC	UTD-HFNB	UTD-HFNA	UTD-HFND	UTD-HFKB	UTD-HFKA	
Net Dimension (H x W x D)	mm	290 x 70 x 6	390 x 70 x 6	290 x 70 x 6 390 x 70 x 6	620 x 88 x 6	420 x 88 x 6	620 x 88 x 6	500 x 79 x 6	420 x 125 x 6	620 x 108 x 6
Weight	g	6	8	10	8	10	16	12	16	20
Quantity		2	2	3	1	2	2	2	2	2

Auto louver grille kit

UTD-GXTA-W / UTD-GXTB-W / UTD-GXTC-W



The optional clean-looking flat Auto louver grille kit blends into any interior and provides a comfortable airflow.



Flexible Control

- The Auto louver grille of the indoor unit can be operated in conjunction with the remote control of the indoor unit.
- Vertical auto swing**
 - Auto airflow direction and auto swing
 - 4 steps selectable
- Auto-closing louver**
 - The louvers will automatically close when the indoor unit stops operating.

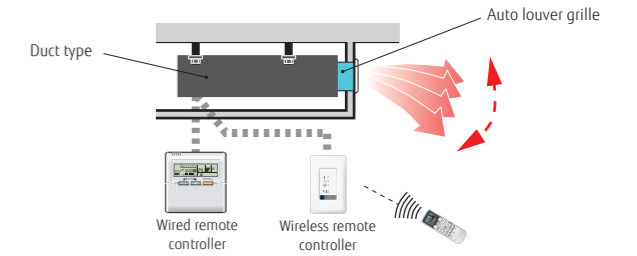

Dimensions

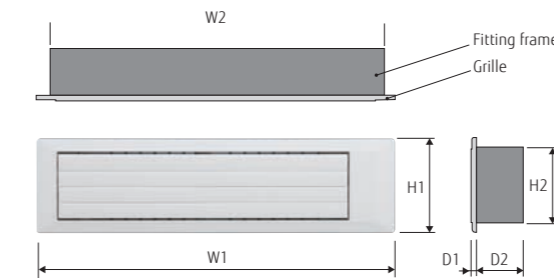

Model name	W1	W2	H1	H2	D1	D2
UTD-GXTA-W	683	645	180	148	9	84
UTD-GXTB-W	883	845	180	148	9	84
UTD-GXTC-W	1,083	1,045	180	148	9	84

Unit: mm

Specifications

Model name	UTD-GXTA-W	UTD-GXTB-W	UTD-GXTC-W		
Applicable indoor unit	ARYG07/09LLTA ARYG12/14LLTB ARXG09/12/14KLLAP ARYG07/09/12/14LSLAP ARXD007/009/012/014GLEH (for VRF) ARXK004/007/009/012/014GLEH (for VRF) ARXD04GALH (for VRF)	ARYG18LLTB ARXG18KLLAP ARYG18LSLAP ARXD018GLEH (for VRF) ARXK018GLEH (for VRF)	ARXD024GLEH (for VRF) ARXK024GLEH (for VRF)		
Power supply	Connecting with Control box of indoor unit				
Fixing Auto louver grille	Screwed to Flange or Square duct				
Extension Square duct limit	1.0 m (Max. duct length between indoor unit and Auto louver grille)				
Net Dimensions (H x W x D)	mm	180 x 683 x (84 + 9)	180 x 883 x (84 + 9)	180 x 1,083 x (84 + 9)	
Weight	Net	kg	2.0 (4.4)	2.5 (5.6)	3.0 (6.7)
	Gross	(lbs)	3.0 (6.7)	3.5 (7.8)	4.0 (8.9)
Color	White				
Louver motor	Stepping motor				
Accessories	Fitting Flame, etc.				
Operating range	Cooling	°C	18 to 32		
		% RH	80 % or less		
Operating range	Heating	°C	16 to 30		

Pressure sensor kit

UTY-SPWX



Design flexibility

The height difference between the outdoor unit and the indoor unit is normally 50 m for the V-IV Series, but can be extended to 110 m by installing the Pressure sensor kit. (Can only be connected to the V-IV Series. Also, it can only be connected to outdoor units using outdoor unit software compatible with the product.)

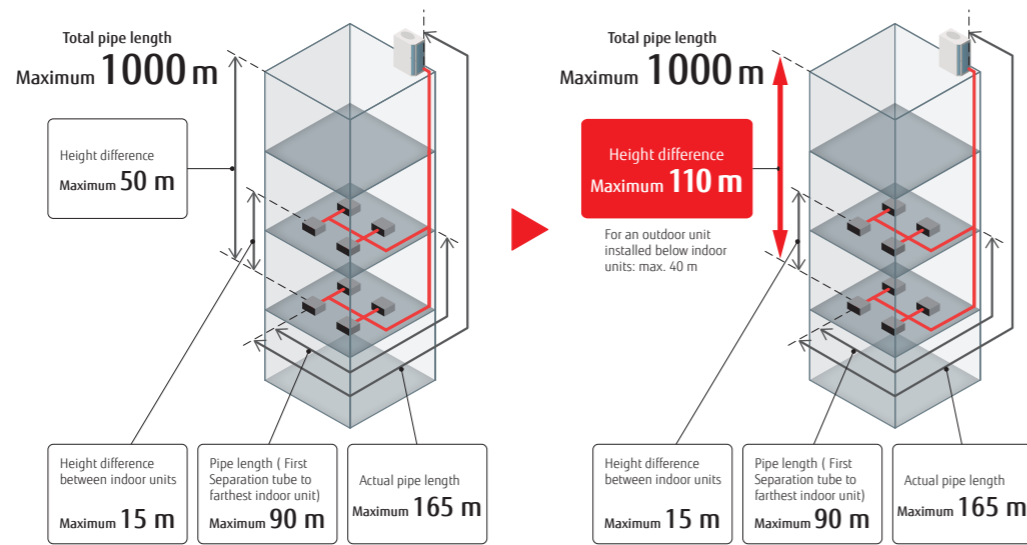

System overview

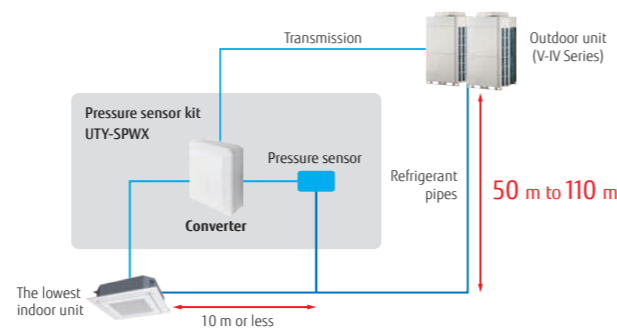

Pressure sensor kit

Pressure sensor kit (Converter)	Refrigerant pressure sensor	Joint pipe

Specifications

Model name	UTY-SPWX
Power supply	9 to 16 V DC
Dimensions (H × W × D) (mm)	140 × 117 × 43
Weight (g)	200

External power supply unit

UTZ-GXXA / UTZ-GXXC



The External power supply unit protects the increment in the system even if the power supply for some of the indoor units is shut down.

Connects to the External power supply unit to supply power to the indoor unit from the auxiliary power supply. This allows for continuous operation without system errors. Built-in relays reduce installation time and cost. The UTZ-GXXC has a built-in relay, which reduces installation time and cost.

High reliability

- A: Interruption of the main power supply is detected by the power cut-off detection part.
- B: Supplies power for driving the expansion valve of the indoor unit. (12 V or 5 V DC)
- C: Gives notification of the power supply from the External power supply unit.

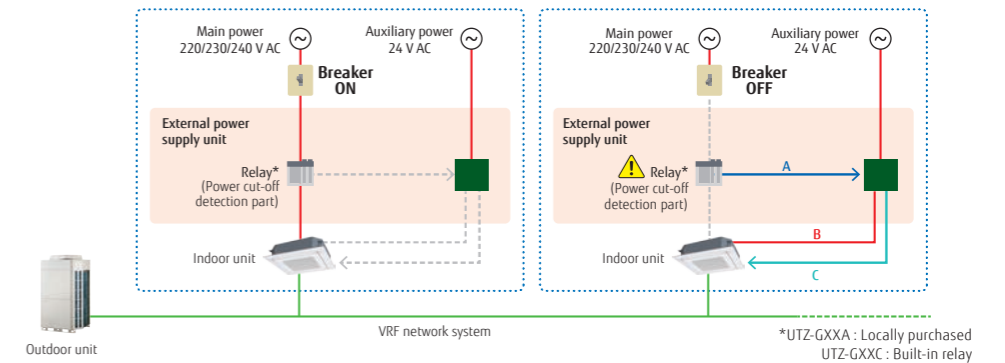

Note

- When changing the power supply voltage to 24 V AC, use a power transformer with an insulated structure that complies with the regulations* of the installation region.
- A powered-off indoor unit driven by the External power supply unit is treated in the same way as an operation-off unit in the electricity charge appointment function. If standby power is generated, the result of the electricity charge appointment may not be zero.

*UL Class II or IEC 61558 Class III, for example.

Specifications

Model name	UTZ-GXXA	UTZ-GXXC
Power supply	24 V AC 50/60 Hz	
Dimensions (H × W × D) (mm)	97 × 200 × 178	
Weight (g)	800	

AIR BEAM Radiation air outlet unit

*Production by order
Contact us for more details.



Key component

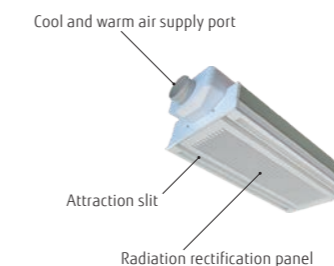

Cross-section view

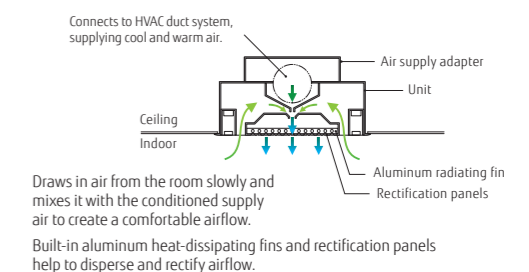

Airflow rate (m ³ /h)	180 (160-215)	270 (240-325)
Grid	600 × 2	600 × 3
AIR BEAM For system ceiling (Integrated type)	KS-180	KS-270

Optional parts list for Split/Multi-split



Type	Refrigerant	Indoor unit																					
		Wall-mounted						Cassette		Duct					Indoor unit			Multi-split					
		Designer Series		Standard Series		ECO Series		4-way flow Compact	Circular flow	Slim	Medium static pressure (High-Efficiency & Comfort)	Medium static pressure (Compact)	Medium static pressure (Standard)	High static pressure	Duct	Floor	Ceiling	4-way flow Compact cassette	Mini duct	Slim duct			
		ASYG 07/09/12/14 KGTF, KGTE	ASYG 07/09/12/14 KETF, KETF-B KEIE, KEIE-B	ASYG 07/09/12/14 KMCF, KMCE ASYG18/24KMTIE	ASYH30/36KMTB	ASYG 07/09/12 KPCE	ASYG18/24KLCA	AUXG 09/12/14/18/22/24 KVLA	AUXG 18/22/24/30/36/45/54 KRLB	ARXG 09/12/14/18 KLLAP	ARXH 22/24/30/36/45/54 KMTAP	ARXG 12/14/18/22/24/30/36/45/54 KHTAP	ARXG22KMLB, ARXG 24/30/36/45 KMLA	ARXG45/54KHTB	ARYG60LHTA	ARYG72/90LHTA	AGYG 09/12/14 KVCA	ABYG 18/22/24/30/36/45/54 KRTA	AUXG07KVLA	ARXG 07/09/12/14/18 KSLAP	ARXG07KLLAP		
Occupancy sensor kit									● UTY-SHZXC														
Remote sensor unit	 The remote sensor provides additional convenience.															● UTY-XSZX21						● UTY-XSZX21	
Cassette grille								● UTG-UFYF-W	● UTG-UKYA-W, UTG-UKYC-W, UTG-UKYA-B											● UTG-UFYF-W (KVLA), UTG-UFYD-W (LVLA)			
Auto louver grille kit										● UTD-GXTA-W (09/12/14) UTD-GXTB-W (18)												● UTD-GXTA-W (07/09/12/14), UTD-GXTB-W (18)	
Silver ion filter			● UTR-FA16-5		● UTR-FA13-3		● UTR-FA16-5	● UTD-HFAA	● UTD-HFRA	● UTD-HFTA (09/12/14) UTD-HFTB (18)	● UTD-HFNB (22/24), UTD-HFNA (30/36/45/54)	● UTD-HFNC (12/14) UTD-HFNB (18/22/24/30) UTD-HFNA (36/45/54)	● UTD-HFND	● UTD-HFKB (45/54)	● UTD-HFKA	● UTR-FA03-5		● UTD-HFAA	● UTD-HFTA (07/09/12/14) UTD-HFTB (18)	● UTD-HFTA			
Long-life filter											● UTD-LFDB (22/24), UTD-LFDA(30/36/45/54)	● UTD-LFNA (36/45/54) UTD-LFNB (18/22/24/30) UTD-LFNC (12/14)	● UTD-LF2SNA	● UTD-LF60KA (45/54)	● UTD-LFKA								
Flange													● UTD-SF045T UTD-RF204										
Drain pump unit													● UTZ-PX1NBA		● UTZ-PX1NAB			● UTR-DPB24T					
Wide Panel									● UTG-AKXA-W														
Panel spacer									● UTG-BKXA-W														
Fresh air intake kit								● UTZ-VXAA	● UTZ-VXRA											● UTZ-VXAA			
Air outlet shutter plate								● UTR-YDZB	● UTR-YDZK											● UTR-YDZB			
Insulation kit for high humidity								● UTZ-KXGC	● UTZ-KXRA											● UTZ-KXGC			
Half concealed kit	 Used to half conceal a floor type indoor unit in the wall.																● UTR-STA						
L-type piping kit																						● UTP-FX24A (18/22/24) UTP-FX35A (30/36/45/54)	

Optional parts list for VRF



Type	Refrigerant	Indoor unit										Indoor unit								Outdoor unit				
		Cassette			Slim type		Large type		Duct			Duct		Floor		Floor/Ceiling		Ceiling		Wall-mounted				V-IV Series
		One-way flow	3D flow	Compact grid type/ Standard type	Circular flow		Mini (With drain pump)	Slim (With drain pump)		High Efficiency	Medium static pressure	High static pressure		-	external EEV	Floor/Ceiling	Ceiling	-	external EEV	-	-			
		AUXV 004/007/009/ 012/014/018/ 024GLEH	AUXS 018/024GLEH	AUXB 004/007/009/ 012/014/018/ 024GLEH	AUXM 018/024/030 GLEH	AUXK 018/024/030/ 034/036/045/ 054GLEH	ARXK 004/007/009/ 012/014/018/ 024GLGH	ARXD 04GALH	ARXD 007/009/012/ 014/018/024 GLEH	ARXP 018/030 GLFH	ARXA 024/030/ 036/045 GLEH	ARXC 036/045/060 GTEH	ARXC 072/090/096 GTEH	AGYA 004/007/ 009/012/014 GCGH	AGYE 004/007/ 009/012/014 GCEH	ABYA 012/014/ 018/024 GTEH	ABYA 030/036/ 045/054 GTEH	ASVA 004/007/009 012/014 GCGH	ASVE 004/007/009 012/014 GCEH	ASVA 18/24GBCH	ASVA 030/034GTEH			
Occupancy sensor kit					● UTY-SHZXC																			
Remote sensor unit							● UTY-XSZXZ1			● UTY-XSZXZ1														
Cassette grille		● UTG-UNYA-W ● UTG-UNYB-W	● UTG-USYA-W	● UTG-UFYE-W ● UTG-UFYCW	● UTG-UNYA-W ● UTG-UNYB-W																			
Auto louver grille kit							● UTD-GXTA-W (4-14), ● UTD-GXTB-W (18), ● UTD-GXTC-W (24)																	
Silver ion filter				● UTD-HFAA	● UTD-HFRA	● UTD-HFTA (004-014) ● UTD-HFTB (018) ● UTD-HFTC (024)	● UTD-HFTA	● UTD-HFTA (007-014) ● UTD-HFTB (018) ● UTD-HFTC (024)	● UTD-HFND	● UTD-HFND	● UTD-HFKB		● UTR-FA03-5					● UTR-FA16-5	● UTR-FA13-3					
Long-life filter									● UTD-LF25NA	● UTD-LF25NA	● UTD-LF60KA													
Flange									● UTD-SF045T ● UTD-RF204	● UTD-SF045T ● UTD-RF204							● UTD-RF204							
Drain Pump Unit									● UTZ-PXINBA	● UTZ-PXINBA							● UTR-DPB24T							
Wide Panel					● UTG-AKXA-W																			
Panel spacer					● UTG-BKXA-W																			
Fresh air intake kit*1				● UTZ-VXAA	● UTZ-VXRA																			
Air outlet shutter plate:				● UTR-YDZB	● UTR-YDZK																			
Insulation kit for high humidity				● UTZ-KXGC	● UTZ-KXRA																			
Half concealed kit														● UTR-SIA										
External power supply unit					● UTZ-GXXA ● UTZ-GXXC									● UTZ-GXXA ● UTZ-GXXC								● UTZ-GXXA ● UTZ-GXXC		
Pressure sensor kit																							● UTY-SPWX	

Function list for Split/Multi-split



External input and output function/External connect kit/communication kit

Type	Refrigerant	Indoor unit											Floor	Ceiling	Multi-split					Outdoor unit												
		Wall-mounted			Cassette		Duct								High static pressure	Big	Mini duct	Slim duct		Compact cassette	Single Split		Simultaneous multi-split									
		Designer Series	Standard Series		ECO Series	Compact 4-way flow Series	Circular flow Series	Slim	Medium static pressure (High-Efficiency & Comfort)	Medium static pressure (Compact)	Medium static pressure (Standard)	ARXG 45/54KHTB						ARXG 12/14/18/22/24/30/36/45/54KHTAP	ARXG 22XMLB, ARXG 24/30/36/45/54KHTAP		ARXG 09/12/14/18/22/24/30/36/45/54KHTA	ASVG 22KMTB	ARXG 07/09/12/14/18/22/24/30/36/45/54KSLAP	ARXG 07/09/12/14/18/22/24/30/36/45/54KSLAP	ARXG 07/09/12/14/18/22/24/30/36/45/54KSLAP	ADYG 07/09/12/14/18/22/24/30/36/45/54KSLAP	ADYG 36/45/54KSLAP	ADYG 36/45/54KSLAP	ADYG 36/45/54KSLAP	ADYG 36/45/54KSLAP		
Indoor	R32	ASVG 07/09/12/14/18/22/24/30/36/45/54KSLAP	ASVG 07/09/12/14/18/22/24/30/36/45/54KSLAP	ASVG 07/09/12/14/18/22/24/30/36/45/54KSLAP	ASVG 18/24KMTB	ASVG 30/36KMTB	ASVG 07/09/12/14/18/22/24/30/36/45/54KSLAP	ASVG 18/24KLLCA	AUXG 09/12/14/18/22/24/30/36/45/54KSLAP	AUXG 18/22/24/30/36/45/54KSLAP	ARXG 09/12/14/18/22/24/30/36/45/54KHTAP	ARXH 22/24/30/36/45/54KHTAP	ARXG 12/14/18/22/24/30/36/45/54KHTAP	ARXG 22XMLB, ARXG 24/30/36/45/54KHTAP	ARXG 45/54KHTB	ARXG 12/14/18/22/24/30/36/45/54KHTAP	ARXG 22XMLB, ARXG 24/30/36/45/54KHTAP	ARXG 09/12/14/18/22/24/30/36/45/54KHTA	ASVG 22KMTB	ARXG 07/09/12/14/18/22/24/30/36/45/54KSLAP	ARXG 07/09/12/14/18/22/24/30/36/45/54KSLAP	ARXG 07/09/12/14/18/22/24/30/36/45/54KSLAP	ADYG 07/09/12/14/18/22/24/30/36/45/54KSLAP	ADYG 36/45/54KSLAP	ADYG 36/45/54KSLAP	ADYG 36/45/54KSLAP	ADYG 36/45/54KSLAP	ADYG 36/45/54KSLAP	ADYG 36/45/54KSLAP	ADYG 36/45/54KSLAP		
Operation/Stop									● PCB Terminal or ○ UTY-XCSX/UTZ-GXDA		● PCB Terminal		● PCB Terminal or ○ UTY-XCSX/UTZ-GXDA		● PCB Terminal or ○ UTY-XCSX/UTZ-GXDA		● PCB Terminal or ○ UTY-XCSX/UTZ-GXDA															
Forced stop											● PCB Terminal				● PCB Terminal or ○ UTY-XCSX/UTZ-GXDA		● PCB Terminal or ○ UTY-XCSX/UTZ-GXDA															
Forced Thermostat off									● UTY-XCSX/UTZ-GXDA				● UTY-XCSX/UTZ-GXDA		● UTY-XCSX/UTZ-GXDA		● UTY-XCSX/UTZ-GXDA															
Low noise mode operation																							○ UTY-XWZXZ3					○ UTY-XWZXZ2				
Outdoor unit operation peak control																							○ UTY-XWZXZ3					○ UTY-XWZXZ2				
Indoor																																
Operation status									○ UTY-XCSX/UTZ-GXDA		○ UTY-XWZXZG or ○ UTY-XCSX/UTZ-GXDA		○ UTY-XWZXZG or ○ UTY-XCSX/UTZ-GXDA		○ UTY-XWZXZG or ○ UTY-XCSX/UTZ-GXDA		○ UTY-XWZXZG or ○ UTY-XCSX/UTZ-GXDA															
Error status									○ UTY-XCSX/UTZ-GXDA		○ UTY-XWZXZG or ○ UTY-XCSX/UTZ-GXDA		○ UTY-XWZXZG or ○ UTY-XCSX/UTZ-GXDA		○ UTY-XWZXZG or ○ UTY-XCSX/UTZ-GXDA		○ UTY-XWZXZG or ○ UTY-XCSX/UTZ-GXDA															
Compressor status																																
Indoor unit fan operation status									○ UTY-XCSX/UTZ-GXDA		○ UTY-XWZXZG or ○ UTY-XCSX/UTZ-GXDA		○ UTY-XWZXZG or ○ UTY-XCSX/UTZ-GXDA		○ UTY-XWZXZG or ○ UTY-XCSX/UTZ-GXDA		○ UTY-XWZXZG or ○ UTY-XCSX/UTZ-GXDA															
Setpoint attainment status																																
Auxiliary heater output									○ UTY-XCSX/UTZ-GXDA		○ UTY-XWZXZG or ○ UTY-XCSX/UTZ-GXDA		○ UTY-XWZXZG or ○ UTY-XCSX/UTZ-GXDA		○ UTY-XWZXZG or ○ UTY-XCSX/UTZ-GXDA		○ UTY-XWZXZG or ○ UTY-XCSX/UTZ-GXDA															

*1: Included in Fresh air intake kit (UTZ-VXAA or UTZ-VXRA) *2: Functionality for installation in a server room

● Dry Contact ○ Apply Voltage

For SPLIT/MULTI-SPLIT/SIMULTANEOUS MULTI-SPLIT

Communication kit

UTY-TWRXZ3 UTY-TWRXZ2

External input and output PCB

UTY-XCSXZ1 (wire length 280 mm)
UTY-XCSXZ2 (wire length 80 mm) for Wall-mounted type UTY-XCSX for Duct and Cassette types

External input and output PCB box

UTZ-GXDA (for Duct)
UTZ-GXRA (for Cassette)
UTZ-GXEA (for Ceiling)

External input and output PCB bracket

UTZ-GXNA

Communication system

External connect kit

UTY-XWZX

UTY-XWZXZ5

UTY-XWZXZG

For outdoor unit

UTY-XWZXZ2

UTY-XWZXZ3

External control set

For indoor unit

UTD-ECS5A

Separation tube



For SPLIT/MULTI-SPLIT/SIMULTANEOUS MULTI-SPLIT

<p>Separation tube</p> <p>UTP-SX236A / UTP-SX254A For 3-phase simultaneous multi-split</p> <p>UTP-SX272A For Simultaneous multi-split Twin/Triple/Double Twin</p>	<p>UTP-SX354A For 3-phase simultaneous multi-split</p> <p>UTP-SX372A For Simultaneous multi-split Twin/Triple/Double Twin</p>
---	---

for VRF

<p>Separation tube</p> <p>UTP-AX054A</p> <p>Gas pipe</p> <p>Liquid pipe</p>	<p>UTP-AX090A</p> <p>Gas pipe</p> <p>Liquid pipe</p>	<p>UTP-AX180A</p> <p>Gas pipe</p> <p>Liquid pipe</p>	<p>UTP-AX567A</p> <p>Gas pipe</p> <p>Liquid pipe</p>
<p>UTP-BX090A</p> <p>Suction Gas pipe</p> <p>Discharge Gas pipe</p> <p>Liquid pipe</p>	<p>UTP-BX180A</p> <p>Suction Gas pipe</p> <p>Discharge Gas pipe</p> <p>Liquid pipe</p>	<p>UTP-BX567A</p> <p>Suction Gas pipe</p> <p>Discharge Gas pipe</p> <p>Liquid pipe</p>	<p>UTP-LX180A For DX kit</p>

Header

<p>UTR-H0906L / UTR-H1806L</p> <p>Gas pipe</p> <p>Liquid pipe</p>	<p>UTR-H0908L / UTR-H1808L</p> <p>Gas pipe</p> <p>Liquid pipe</p>	<p>UTP-J0906A / UTP-J1806A</p> <p>Suction gas pipe</p> <p>Discharge gas pipe</p> <p>Liquid pipe</p>	<p>UTP-J0908A / UTP-J1808A</p> <p>Suction gas pipe</p> <p>Discharge gas pipe</p> <p>Liquid pipe</p>
---	---	---	---

Outdoor unit branch kit

<p>UTP-CX567A</p> <p>Gas Pipe</p> <p>Liquid Pipe</p>	<p>UTP-DX567A</p> <p>Suction Gas Pipe</p> <p>Discharge Gas Pipe</p> <p>Liquid Pipe</p>	<p>UTP-EX060A</p> <p>Gas Pipe</p> <p>Liquid Pipe</p>	<p>UTP-EX096A</p> <p>Gas Pipe</p> <p>Liquid Pipe</p>
--	--	--	--

Separation tube for RB unit

for VRF

<p>EV kit</p> <p>Model name \leq 09: UTR-EV09XB Model name \geq 12: UTR-EV14XB for compact wall-mounted type</p>
--

<p>RB unit</p> <p>UTP-RX01AH / UTP-RX01BH / UTP-RX01CH Single type</p>	<p>UTP-RX04BH Multi-split type</p>	<p>UTP-RX08AH Multi-split type</p>	<p>UTP-RX12AH Multi-split type</p>
--	--	--	--

Specifications

Separation tube

Model name	UTP-AX054A	UTP-AX090A	UTP-AX180A	UTP-AX567A
Total cooling capacity of indoor unit (kW)	19.6 or less	28.0 or less	28.1 to 56.0	56.1 or more

Model name	UTP-BX090A	UTP-BX180A	UTP-BX567A
Total cooling capacity of indoor unit (kW)	28.0 or less	28.1 to 56.0	56.1 or more

Header

Model name	3-6 Branches	UTR-H0906L	UTR-H1806L
	3-8 Branches	UTR-H0908L	UTR-H1808L
Total cooling capacity of indoor unit (kW)		28.0 or less	28.1 to 56.0

Model name	3-6 Branches	UTP-J0906A	UTP-J1806A
	3-8 Branches	UTP-J0908A	UTP-J1808A
Total cooling capacity of indoor unit (kW)		28.0 or less	28.1 to 56.0

Outdoor unit branch kit

Model name	UTP-CX567A (for V-IV)		UTP-DX567A (for VR-IV)	
Number of outdoor units	2 outdoor units	1		
	3 outdoor units	2		

EV kit

Model name	UTR-EV09XB		UTR-EV14XB	
Application model	ASYE004GCEH ASYE007GCEH ASYE009GCEH	AGYE004GCEH AGYE007GCEH AGYE009GCEH	ASYE012GCEH ASYE014GCEH	AGYE012GCEH AGYE014GCEH

RB unit

Type	Single type			Multi-split type		
Model name	UTP-RX01AH	UTP-RX01BH	UTP-RX01CH	UTP-RX04BH	UTP-RX08AH	UTP-RX12AH
Power source	V/Ø/Hz 230/1/50					
Input power	W	17	24	31	96	204
Number of branches	1	1	1	4	8	12
Maximum capacity of connectable indoor units (Q)	kW	Q \leq 8.0	Q \leq 18.0	Q \leq 28.0	Q \leq 56.1*1	Q \leq 95.0
Maximum capacity of connectable indoor units per branch (Q)	kW	Q \leq 8.0	Q \leq 18.0	Q \leq 28.0	Q \leq 18.0	Q \leq 8.0
Maximum Connectable Indoor Units per Branch		3	8	8	7	7
Dimensions (H × W × D)	mm	198 × 298 × 268			260 × 658 × 428	298 × 660 × 618

*1: When two RB units are connected in series (8 branches in total), the maximum capacity of the connectable indoor units is up to 56.0 kW.