

HEAT PUMP
VRF CATALOGUE
 2024
 for Saudi Arabia

HEAT PUMP VRF CATALOGUE 2024 for Saudi Arabia

FUJITSU GENERAL LIMITED



Fujitsu General (Thailand) Co., Ltd.



ISO 9001 Certification number: 01 100 075229
 ISO 14001 Certification number: 01 104 9245

Fujitsu General (Shanghai) Co., Ltd.



ISO 9001 Certification number: 01 100 79269
 ISO 14001 Certification number: CNB312244-UK

Fujitsu General Central Air-conditioner (Wuxi) Co., Ltd.



ISO 9001 Certification number: 15917020073RSM
 ISO 14001 Certification number: 15918E20021RSM

- Specifications and design are subject to change without notice for future improvement.
- For further details, please check with our authorised dealer.
- The products or equipments in this catalogue contain fluorinated greenhouse gases.
- "GENERAL" and "AIRSTAGE" are worldwide trademarks of FUJITSU GENERAL LIMITED and are registered trademarks in Japan and other countries or areas.
- "PULAIR" is a worldwide trademark of FUJITSU GENERAL LIMITED.
- iPhone and iPad are trademarks of Apple Inc., registered in the U.S. and other countries.
- "BACnet" is a trademark or registered trademark of the American Society of Heating, Refrigerating and Air-Conditioning Engineers, Inc.
- "MODBUS" is a registered trademark of Schneider Electric.
- "LONWORKS" and Echelon are trademarks of Echelon Corporation registered in the United States and other countries.
- Other company and product names mentioned herein may be registered trademarks, trademarks or trade names of their respective owners.
- Actual products' colors may be different from the colors shown in this printed material.

Distributed by :

Zagzoog for Home Appliances الزقزوق للأجهزة المنزلية

info@zagzoog.com ٩٢٠٠٠٤١١١ الرقم الموحد لخدمات العملاء ٩٢٠٠٢٢٧٦٦ الرقم الموحد للشركة
 www.zagzoog.com / ZagzoogKSA

FUJITSU GENERAL LIMITED

3-3-17, Suenaga, Takatsu-ku, Kawasaki, Kanagawa, 213-8502, Japan
 www.fujitsu-general.com



Copyright© 2008-2024 Fujitsu General Limited. All rights reserved. 6MG510-2402E

FUJITSU GENERAL Way

Our Mission

Living together for our future

Through innovation and technology, we deliver a brighter future with the peace of mind to our customers and societies around the world.

Our Philosophy

Act Spontaneously

We embrace new challenges by investing in ourselves for personal growth, and through continuous creativity with a spontaneous attitude.

Develop Our Team

We respect and value our people, and optimize their abilities through fostering culture and diversity, and utilizing a collaborative effort focused on communication.

Value Integrity

To achieve our goals, we always act with integrity and shared ethics.

CONTENTS

OUR MESSAGE

OUR HISTORY	4
WORLDWIDE LOCATIONS	6
GLOBAL BUSINESS ACTIVITIES	8
PROJECT REFERENCE	10
GLOBAL DEVELOPMENT & PRODUCTION BASES	12
HIGH QUALITY DEVELOPMENT & PRODUCTION FACILITIES	14

VRF Solutions

OUR SOLUTION FOR ALL PROPERTIES	16
Light Commercial Solutions	18
Commercial Solutions	26

VRF CORE TECHNOLOGY

HIGH ENERGY EFFICIENCY	30
HIGH RELIABILITY	32
DESIGN FLEXIBILITY	34
MORE COMFORT	36
EASY INSTALLATION	38
EASY SERVICE & MAINTENANCE	40

VRF OUTDOOR UNITS

VRF LINE-UP	44
-------------------	----

For SMALL BUILDING 46

VRF J-III Tropical Series

Heat Pump type for heating or cooling operation
4 HP - 6 HP 6 Models
• Single phase: 4 HP to 6 HP/3 models
• 3 phase: 4 HP to 6 HP/3 models

For LARGE BUILDING 50

VRF V-III Tropical Series

Production by order

Heat Pump Modular type for heating or cooling operation
8 HP - 48 HP 32 Models
• Space saving combination: 8 HP to 48 HP/21 models
• Energy efficiency combination: 20 HP to 42 HP/11 models

VRF INDOOR UNITS

INDOOR UNITS LINE-UP	58
Compact Cassette	60
Circular Flow Cassette	62
Slim Duct / Slim Concealed Floor	64
Medium Static Pressure Duct	66
High Static Pressure Duct	68
Large Airflow Duct	72
Floor / Ceiling	74
Ceiling	76
Wall Mounted (EEV Internal)	78

VRF CONTROL SYSTEMS

BEST CONTROL SOLUTION FOR EACH PROPERTY.....	84
CONTROL SYSTEM OVERVIEW	86
COMPARISON TABLE OF CONTROLLERS	88
• Individual Controller	90
• Centralized Controller	98
• Converter / Adaptor	104

VENTILATION

Outdoor-air Processing Unit	114
DX Kit for Air Handling Unit or Fresh Air Handling Unit application	116

VRF OPTION

Pressure Sensor Kit	120
Auto Louver Grille Kit	121
CONTROL SYSTEM LIST.....	122
OPTIONAL PARTS LIST.....	124
OPTIONAL PARTS.....	126
FUNCTION LIST.....	130
SEPARATION TUBE etc.....	132

SUPPORT

VRF SUPPRT	136
HVAC SYSTEM DESIGN SUPPORT TOOL	138
QUICK SERVICE & MAINTENANCE	140
SERVICE TOOL	142
WEB MONITORING TOOL	143



OUR HISTORY

Overseas Air Conditioning Business since 1971
VRF Business since 2001

FUJITSU GENERAL's VRF Series has been developed based on our long-term air-conditioning technology know-how and was first provided 14 years ago. We have offered a series of products from large homes to large-scale buildings to meet the various market needs.

For Commercial Use

2001

10HP / Heat recovery & Heat pump

2003

10HP / Heat recovery 8,10HP / Heat pump & Cooling



S

2007

8 to 42HP / Heat pump



VRF V

2009

High efficiency and Compact design model
Extensive lineup from 8HP to 48HP
in 2HP increment / Heat pump



VRF V-II

2012

High efficiency and Compact design model
8 to 48HP / Heat Recovery



VRF VR-II

2013

Tropical spec model
Extensive lineup from 8HP to 42HP in 2HP
increment / Heat pump



VRF V-II

2015

High efficiency and large capacity model.
Extensive lineup from 8HP to 54HP in
2HP increment / Heat pump



VRF V-III

2016

Tropical spec model
Extensive lineup from 8HP to 54HP in 2HP
increment / Heat pump



VRF V-III

For Residential & Light Commercial Use

2004

Small VRF Series is released. 6HP / Heat pump



VRF J

2011

High efficiency and small capacity model
4HP to 6HP / Heat pump



VRF J-II

2014

High efficiency and compact design model
4HP to 6HP / Heat pump



VRF J-IIS

2016

High efficiency and small capacity model
4HP to 6HP / Heat pump



VRF J-III

2017

Tropical spec model
High efficiency and compact design model
4HP to 6HP / Heat pump



VRF J-III

2017

High efficiency and compact design model
10HP to 12HP / Heat pump



VRF J-III L

AIRSTAGE™ History

1936 Established as Yaou Shouten Ltd. - 2017

1936 Established as Yaou Shouten Ltd.

1971 Air conditioner exports to Middle East.

Certification Acquisition of

ISO14001

1998 : Fujitsu General (Shanghai) Co.,Ltd.
1999 : Fujitsu General (Thailand) co.,Ltd.
2002 : FGA (Thailand) Co.,Ltd.
2006 : Fujitsu General Central Air-conditioner (Wuxi) co.,Ltd.

New Product Initiatives
Fujitsu introduced inverter technology which used R410A refrigerant.



RoHS Compliant
Restriction of Hazardous Substances (ROHS) is an EU directive on the restriction of the use of certain hazardous substances in all consumer electrical and electronic equipment.



DC Inverter Compressors
Use of 100% inverter driven DC compressors.



WORLDWIDE LOCATIONS

Under a system of five bases in Europe, the Middle East, Asia and Oceania, North and South America, and Japan, the company promotes Globalization from a worldwide perspective while emphasizing the actual conditions in each region.



JAPAN Head Office



Technology research building (Japan)

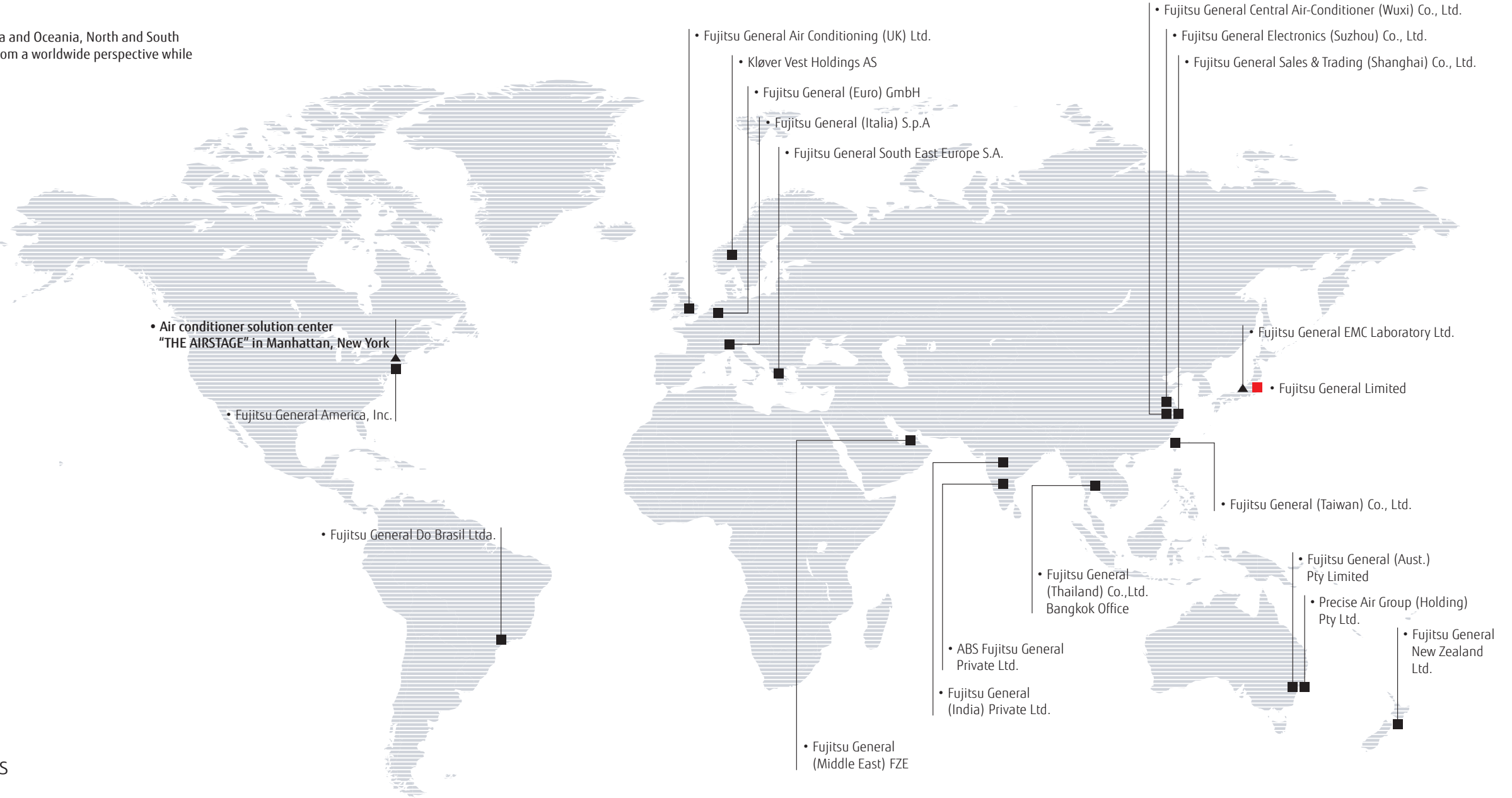

18 Overseas Sales Companies

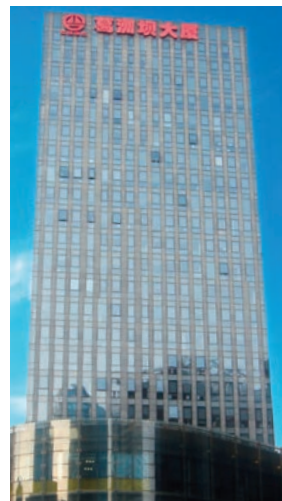

Fujitsu General Sales & Trading (Shanghai) Co., Ltd.



Fujitsu General (Taiwan) Co., Ltd. (Taiwan)



Fujitsu General (Thailand) Co.,Ltd. Bangkok Office (Thailand)

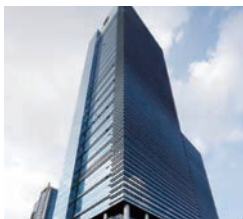

Fujitsu General Electronics (Suzhou) Co., Ltd.



Fujitsu General South East Europe S.A. (Greece)



Fujitsu General (EURO) GmbH (Germany)



Fujitsu General Air Conditioning (UK) Ltd. (U.K.)



Fujitsu General (Italia) S.p.A (Italy)



Fujitsu General (India) Private Ltd. (India)



Fujitsu General (Aust.) Pty Ltd. (Australia)



Precise Air Group (Holding) Pty Ltd. (Australia)



Fujitsu General New Zealand Ltd. (New Zealand)



Fujitsu General (Middle East) FZE (U.A.E.)



ABS Fujitsu General Private Ltd. (India)

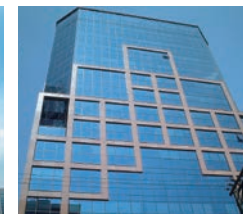

Fujitsu General Do Brasil Ltda. (Brasil)



Fujitsu General America, Inc. (U.S.A.)



Kløver Vest Holdings AS (Norway)



FUJITSU GENERAL SOLUTION CENTER "THE AIRSTAGE" (U.S.A.)

GLOBAL BUSINESS ACTIVITIES

We have been recognized for our activities in advertising, human resource development and customer service, as well as for our community-based social contribution activities in each region, winning numerous awards and achieving a high level of customer satisfaction.

North and South Americas



AHR Expo



HVAC trade shows in Brazil



Distributor conference in USA



Call center

Middle East



Exhibition



Training in Kuwait



Launch event in Oman

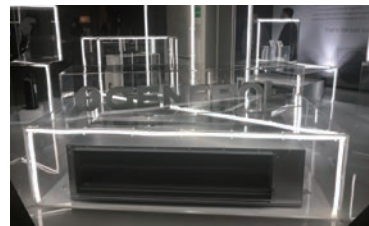

New product seminar in UAE

International authoritative design awards



The NEWS Dealer Design Awards



Gold Award (Category: HVAC & PLUMBING) in Reader's Choice Awards



TOP OF MIND 2016 First prize in "MARCA DE EQUIPAMENTO DE AR-CONDICIONADO" category of "CLIMATIZACAO" division



Superbrands is the world's largest independent arbiter of branding.



The iF Product Design Award is given annually by iF International Forum Design GmbH for industrial products from around the world.



The Plus X Award is the world's largest innovation award for technology, sports and lifestyle.



reddot winner 2020

A product design competition that has been held since 1955. Products that win the award are given the "Red Dot" seal, a sign of international recognition of quality.



One of the famous design award in the world. Designs are judged on innovation and aesthetics, as well as their benefit to users, clients/brands, and society.



ProductReview.com.au's annual awards are selected from products and services that have been well-rated by the ProductReview community.



Voted by Australians as the 'Most Trusted Brand - Air Conditioning Category 5 Years Running'



China State Construction Engineering Luban Prize



The Good Design Award is an award sponsored by the Japan Institute of Design Promotion, and is given once a year to items of outstanding design.

PROJECT REFERENCES

Introduced in over 50 countries worldwide

Highly popular for their excellent quality, energy efficiency, and ease of installation, Fujitsu General's products are installed in a wide range of buildings around the world, including high-rise office buildings, stores, hotels, public facilities, schools, hospitals, and residences.

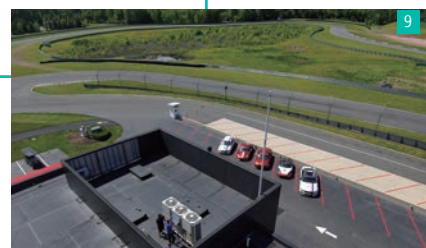
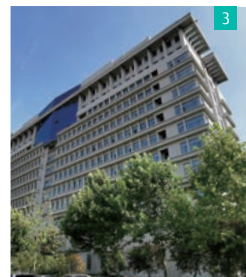

For Light commercial use

- 1 Shop in Europe
- 2 Factory in Europe
- 3 School in Asia
- 4 Hospital in Asia
- 5 Office in Asia
- 6 Shop in Oceania
- 7 Office in Oceania
- 8 School in the Middle East
- 9 Public facility in the United States



For Commercial use

- 10 Public Square in Asia
- 11 Hotel in Asia
- 12 Hotel in Asia
- 13 Public facility in Asia
- 14 Apartment in Oceania
- 15 Apartment in Oceania
- 16 Hotel in the Middle East
- 17 Hotel in the Middle East

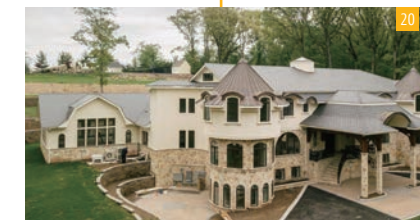

For Residential use

- 18 Villa in the Africa
- 19 Residence in Oceania
- 20 Residence in the United States
- 21 Villa in the Middle East

GLOBAL DEVELOPMENT & PRODUCTION BASES

R&D centers are set up in five countries of Japan, Europe, Asia, China and North America in the world. We pursue the environmental property and comfort to meet each area needs.

- Head Office
- R&D Center
- Manufacturing Companies



R&D center & Technology Research Building



R&D center in Fujitsu General (EURO) GmbH (Germany)



North America R&D Center (USA)



Fujitsu General Air Conditioning R&D (Thailand) Co., Ltd. (Thailand)



R&D center in Fujitsu General (Shanghai)



JAPAN Head office, R&D center and 60 m height difference testing tower (Japan)

Technology research building in Japan Head office



Constructing IoT-based manufacturing

We are implementing a real-time IoT-enabled system to immediately visualize and analyze various information such as facility operating status, assembly line production progress, and parts inventory and transportation status. This will further enhance the accuracy of production and shipping forecasts in the Head Office and factory management departments. The system will also help improve activities by employees at production sites, with the aim of improving the efficiency of the production process, the efficiency of parts distribution operations, and the utilization rates of the facilities.



Fujitsu General (Thailand) Co., Ltd. (Thailand) Factory-2



Fujitsu General (Thailand) Co., Ltd. (Thailand)



Fujitsu General Air Conditioning R&D (Thailand) Co., Ltd. (Thailand)



FGA (Thailand) Co., Ltd. (Thailand)



TCFG Compressor (Thailand) Co., Ltd. (Thailand)

Overseas manufacturing companies



Fujitsu General (Shanghai) Co., Ltd. (China)



F.G.L.S Electric Co., Ltd. (China)



Fujitsu General Central Air-conditioner (Wuxi) Co., Ltd. (China)



Fujitsu General Electronics Ltd. (Japan)

HIGH-QUALITY DEVELOPMENT & PRODUCTION

Advanced Research Facilities and Equipment

Performance tests



Airflow measurement room
Measure the airflow of air conditioners, from compact room air conditioner models to variable refrigerant flow (VRF) systems.



Calorimeter
Measure the temperature, humidity, and airflow at the inlet and outlet of the air conditioner to evaluate its cooling and heating capacity.



Silent room
Measure the operating sounds of air conditioners on walls and ceilings with reduced sound reflection.

Fujitsu General is one of Japan's leading manufacturers with R&D centers in Japan. The research and development conducted in these facilities contributes to providing our customers with the highest quality and performance.

Reliability tests



Constant temperature room
Verify product performance in cooling and heating operations under various temperature and humidity conditions.



Practical test room
Check whether the performance of the air conditioner can be sustained under the conditions of the actual housing environment.



Shower test room
Check if the electrical box of the outdoor unit is protected from strong wind and rain, such as during a typhoon.

Transportation and Handling Tests

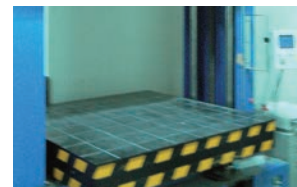

Compressibility test



Vibration test



Technology research building in Japan Head office

Testing laboratory

Fujitsu General EMC Laboratory Limited

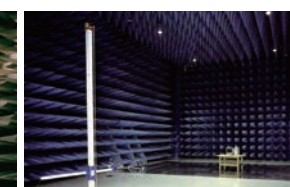
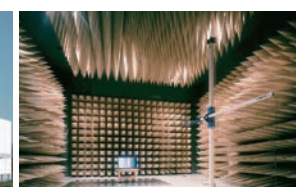

60-m Height Difference testing tower

Tests oil circulation in a compressor for reliability.



FACILITIES

Certification of ISO 9001 and ISO 14001

■ ISO 9001
■ ISO 14001
() Number of companies

The Group's 5 overseas production subsidiaries are individually certified with ISO 9001 and ISO 14001. The Group's 11 overseas sales subsidiaries have been certified with ISO 14001 since 2012.

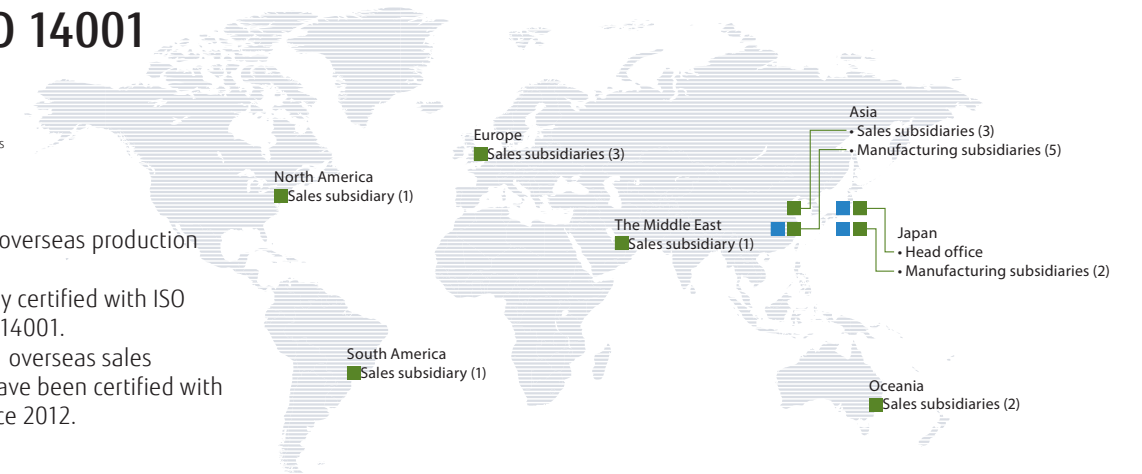

Product Quality Assurance

All Fujitsu General plants are ISO 9001 certified and operate under a unified quality control system. We deliver to customers all over the world high-quality products that have passed stringent quality inspections.

Receiving inspection

We require all our parts suppliers to submit test reports to ensure that all parts we receive from them meet our quality standards. Our in-house test department inspects incoming parts to ensure their compliance with RoHS as required by the EU. We also conduct 100% inspection of main parts to prevent defective parts from making it to assembly lines.

Quality inspection of products

We carry out stringent quality inspections in all production processes performed in our plants. To keep the quality of our products high, inspectors check their quality from start to finish on production lines.

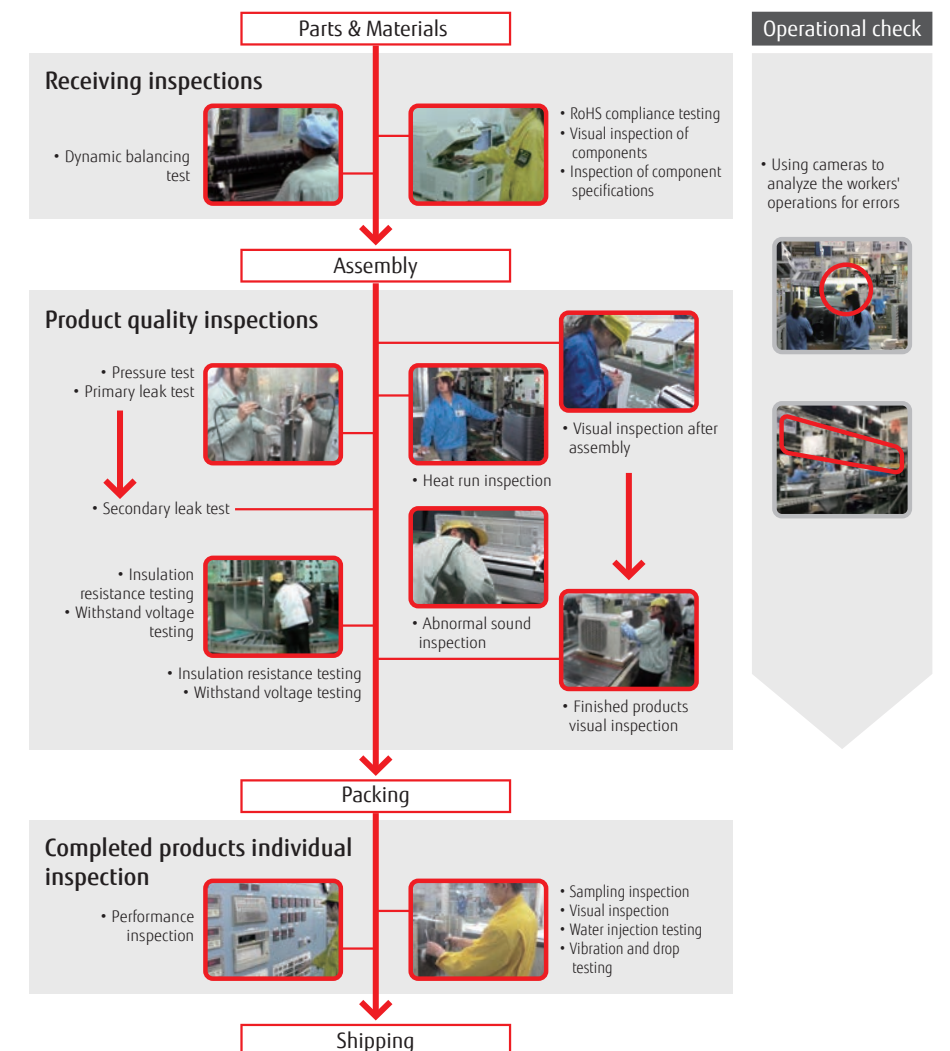

OUR SOLUTION FOR ALL PROPERTIES

Fujitsu General provides the best solutions suitable for properties.

Solution Point

We provide Fujitsu General total solutions for the property unique needs.



Target Property



LIGHT COMMERCIAL

For Small offices, Hotels, School, Shops and Restaurant etc.

We offer comfortable and economical air conditioning systems focused on small to medium-sized buildings.



COMMERCIAL

For Large Building

We provide single and modular type VRF systems designed for high efficiency, comfort, freedom of design, easy installation and high reliability.



Light Commercial

APARTMENT, VILLA

Fujitsu General offers the small VRF system to match from large living rooms to bedrooms for apartment and villa.

APARTMENT

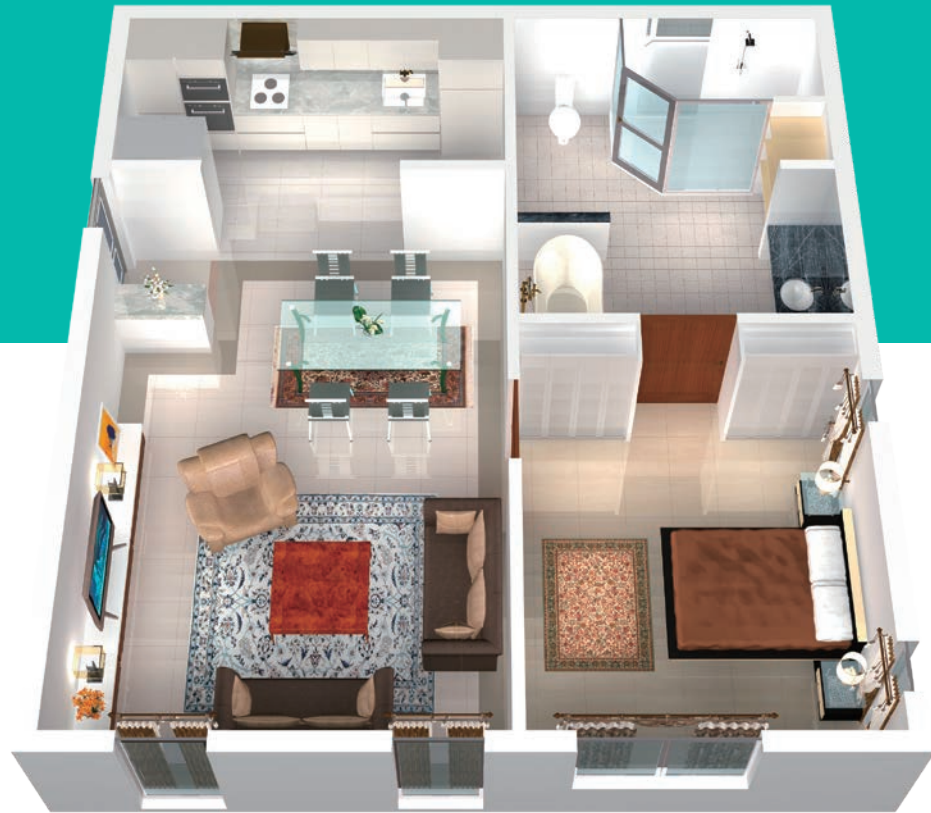

VILLA



Large space air conditioning in a family room

High Static Pressure Duct



Small space air conditioning

Various ranges of low capacity indoor units to suit small space such as a guest room



Compact Wall Mounted

Comfortable dining air conditioning with powerful airflow



Large Wall Mounted

Large space air conditioning in the dining and living room

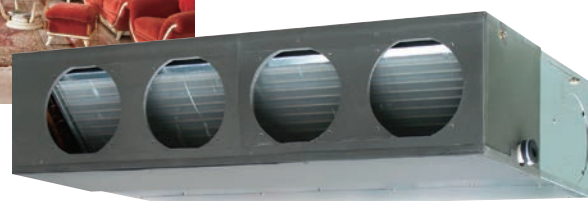

Medium Static Pressure Duct

Small space air conditioning

Space saving
Slim duct type with 198 mm height. This can be installed in narrow ceiling space easily.

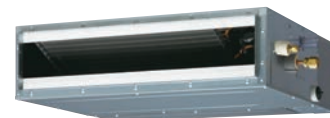

Slim Duct

Light Commercial

HOTELS

Fujitsu General provides perfect total air conditioning systems that take into account comfort, energy saving, external appearance, safety and easy installation for small low-rise hotels.

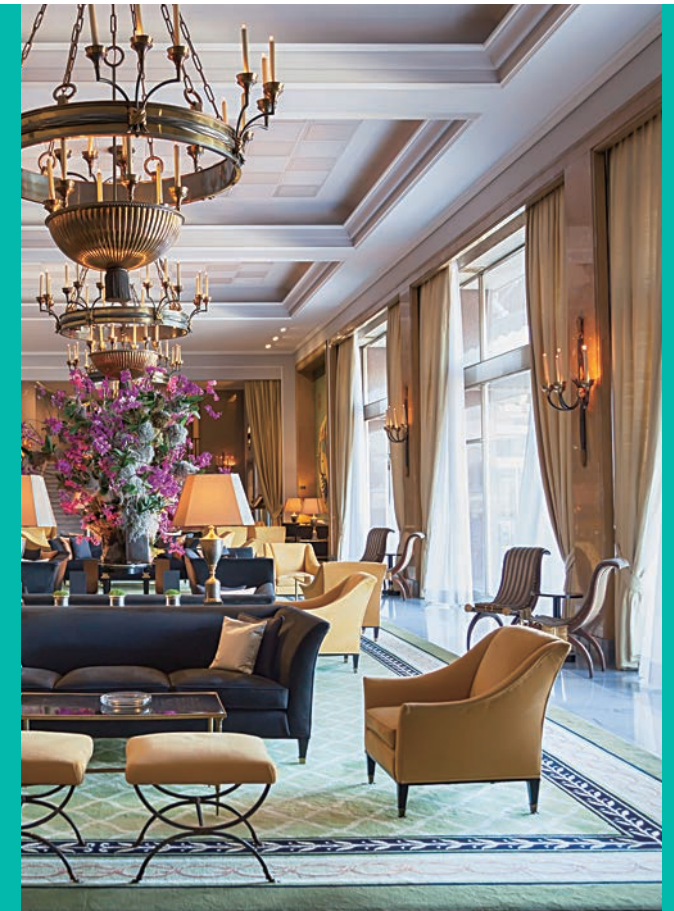

Large space air conditioning in the reception and lobby

Ultra-large duct type single split system suitable for large spaces with high ceilings

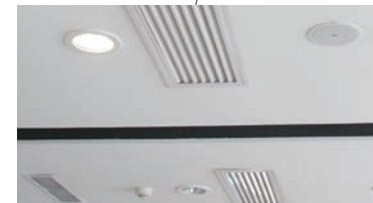

Ventilation of the whole hotel supported

Outdoor air processing is essential in hotel spaces with a high degree of airtightness. The DX Kit can link up with air conditioners to ensure sufficient ventilation. This system can be expanded.

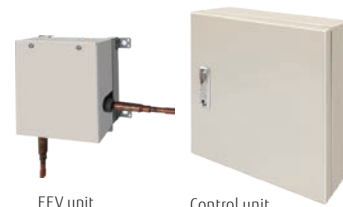

EEV unit Control unit



System controller

Centralized control of air conditioning in shared spaces

Air conditioning in shared spaces such as lobbies and hallways is controlled centrally. Temperature and operating conditions can be managed without the adjustment by guests.



Guest room air conditioning with excellent comfort, energy saving and easy installation

Space saving
Slim duct type with 198 mm height. This can be installed in narrow ceiling space easily.

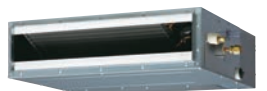

Slim Duct

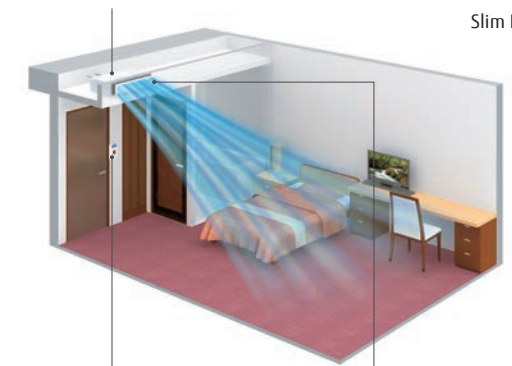

Card key switch available
Using the card key prevents you from forgetting to switch off the air conditioner.

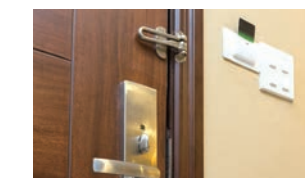

Use of an external connect switch

Comfortable airflow that switches up and down air directions
The Auto Louver Grille Kit achieves comfortable airflow by adjusting the air direction.



Auto Louver Grille Kit

Simple Remote Controller with sophisticated design

Suitable for hotels or offices as it is easily operated with no complex functions. Large LCD screen & simple operation buttons White colored backlight on monitor enable easy operation in dark.



Light Commercial

SCHOOL

Fujitsu General provides the optimal number of connected indoor units for mid-sized educational institutions. The degree of freedom of the installation location selection is improved with a compact design that minimizes the installation area. Even one outdoor unit can cover the entire school building.

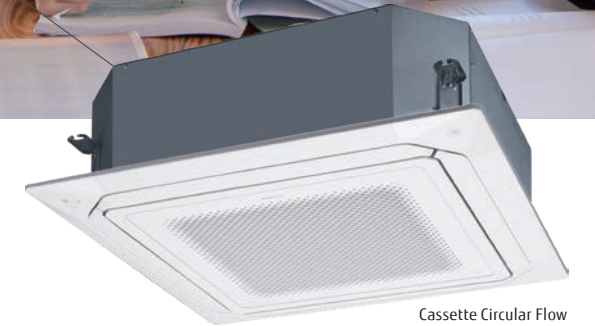

Cassette Circular Flow

Comfortable room air conditioning without airflow feeling

Circular Airflow Cassette blows out in all directions without temperature unevenness



Individual airflow direction control to prevent people from being exposed to airflow



Energy saving operation when there are no people by linking up with human sensor



Human sensor (Option)



Ceiling



Cassette Circular Flow



Wall Mounted

Various indoor units

We have a lineup of indoor units that can also support complex applications – from normal classrooms to special classrooms and auditoriums. Air conditioners can be also added easily.

NEW



Central Remote Controller UTU-DCGGZ3

Central remote controller with improved operability

Controls the temperature of each room easily, and manages and sets the operation control for a week. Energy-saving management by setting upper and lower temperature limits and operating prohibitions.



PC



Router

Fixed IP, IP forwarding and open Port required



Control and monitoring

You can operate the main unit from your desk. Non-administrators can also operate the air conditioners with a computer, smartphone or tablet PC.



Tablet PC

Smartphone

iOS, Android and/or Windows

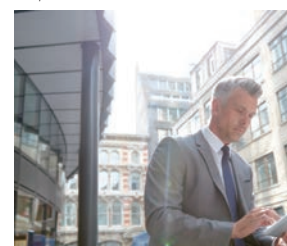

Light Commercial

RESTAURANT, SHOPS

Fujitsu General provides perfect total air conditioning systems that offer smooth support by tenant, by purpose and by customer visit frequency in shops and restaurants with multiple lighting and a high density of customers.



RESTAURANT

SHOPS

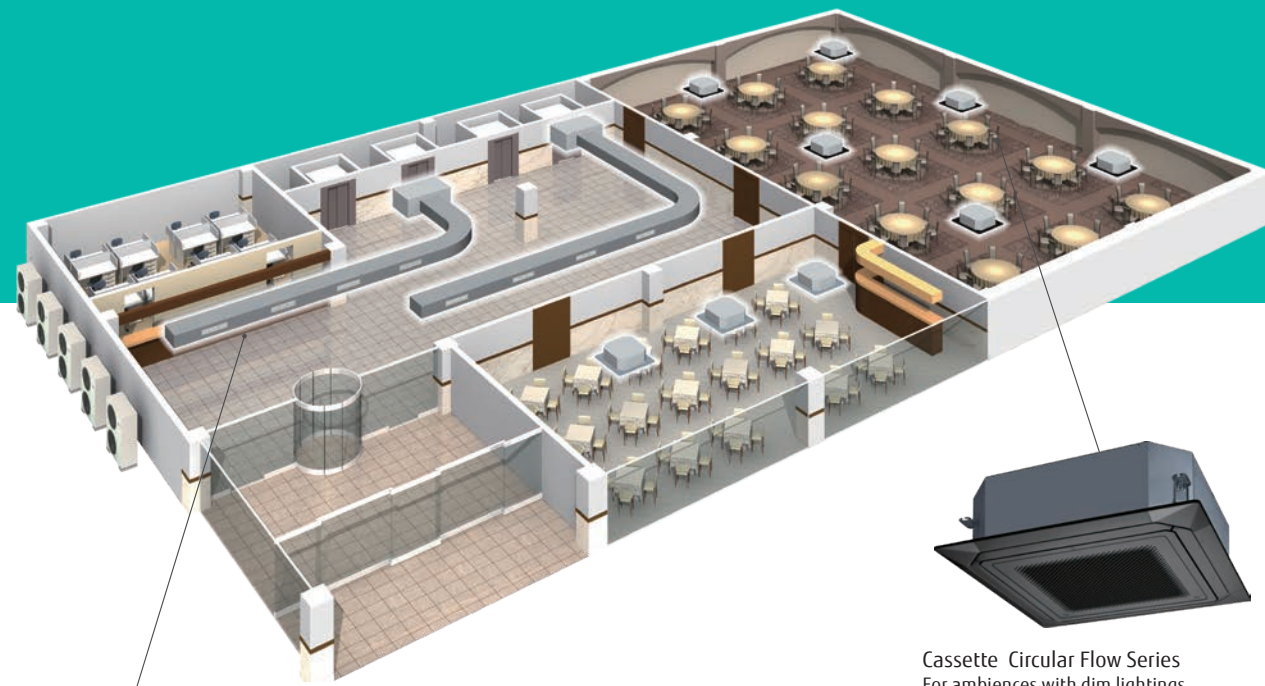

Cassette Circular Flow Series
For ambiances with dim lightings

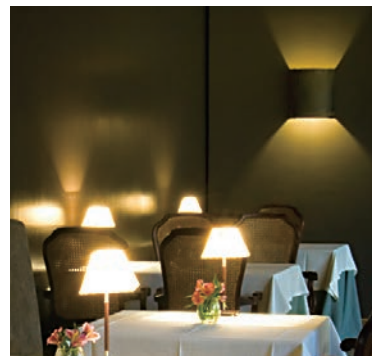

Color variations by two panels

Both black and white panels are available for Cassette type. Black panel is suitable for the dark place such as a restaurant with atmosphere. White panel is usually used at bright areas such as offices. (Available to single split and VRF indoor units)

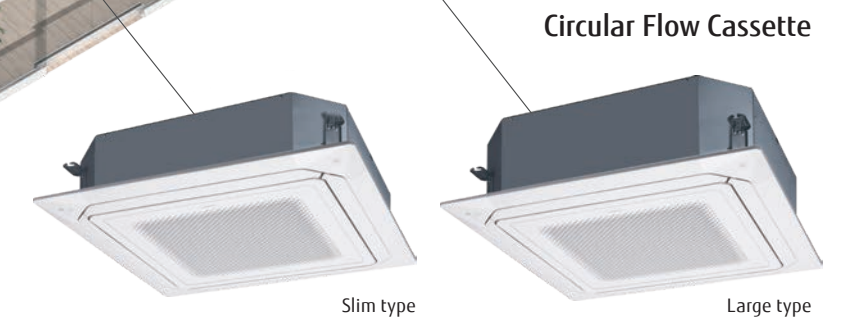

Circular Flow Cassette

Slim type

Large type

Appropriate air conditioning in the atrium space

Appropriate air conditioning of the high ceiling and glass-sided atrium space with a large duct system

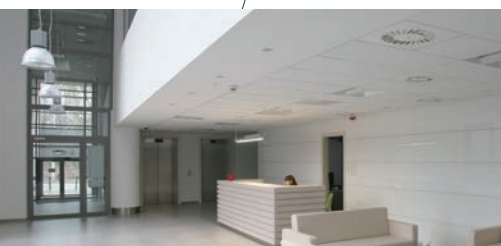

High Static Pressure Duct



Uniform temperature air conditioning

Achieve a comfortable air conditioning spread to every corner of the room by circular flow & wide vertical airflow.



Commercial

LARGE BUILDING

Fujitsu General provides modular type VRF systems that seek high efficiency, comfort, design freedom, easy installation and reliability for skyscraper buildings.



Individual air conditioning system for large buildings

VRF Series lineup to meet various needs such as energy saving-orientated models and models compatible with a high outdoor air temperature of 52°C



VRF V-III Tropical Series

- 8 HP - 48 HP 32 Models
- Space saving combination: 8 HP to 48 HP/21 models
- Energy efficiency combination: 20 HP to 42 HP/ 11 models

Centralized control of both air conditioning and lighting

It is possible to perform centralized control to stop the operation of lighting and ventilation equipment in addition to air conditioner. This is useful in energy saving management over the whole building.

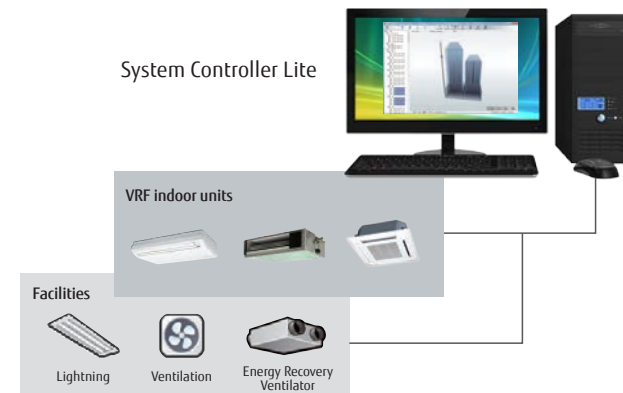

Unique Circular Flow design

New Cassette type realizes Circular Flow to blow large airflow in 360° direction by mounting high performance DC fan motor, new turbo fan and unique seamless airflow louver design.

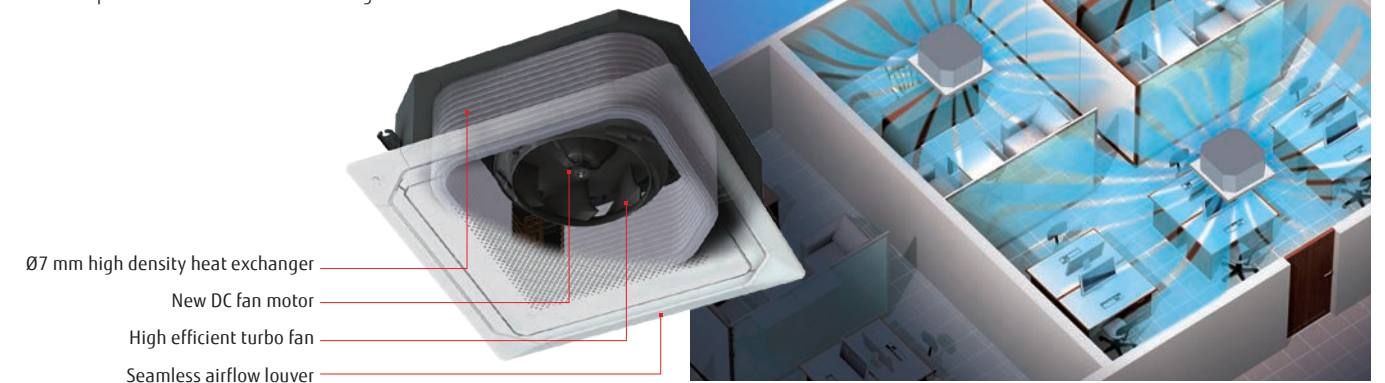

Ventilation(AHU) linked with VRF system

Fujitsu General's DX Kit enable other manufacture's air handling units (AHU) to be incorporated into a Fujitsu VRF system. Possible to control comfortable air conditioning and ventilation.

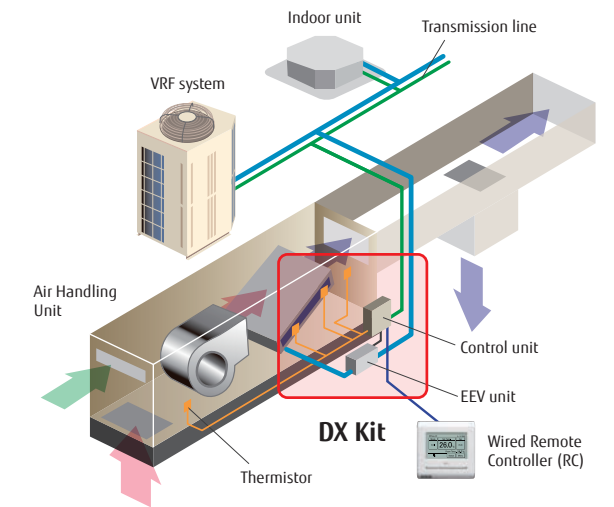

Difference in height Up to 110 m

The height difference between the outdoor unit and the indoor unit is usually 50 m for the V-III Series, but by installing the pressure sensor kit it is possible to expand it to 110 m.

(*This product can be used connected only V-III tropical Series.)

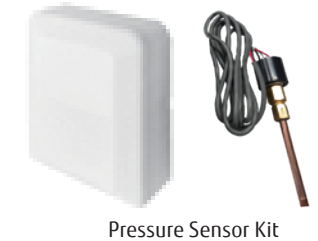

VRF CORE TECHNOLOGY

HIGH ENERGY EFFICIENCY

HIGH RELIABILITY

DESIGN FLEXIBILITY

MORE COMFORT

EASY INSTALLATION

EASY SERVICE & MAINTENANCE

VRF systems can be designed to create an air conditioning solution to suit most buildings requirements.

VRF Systems can be designed to effectively provide an air conditioning solution from a large domestic residence through to a large scale commercial building.

HIGH ENERGY EFFICIENCY



Highly Energy Efficiency

Significantly efficiency is improved by using DC twin rotary compressor, inverter technology, and large heat exchanger.

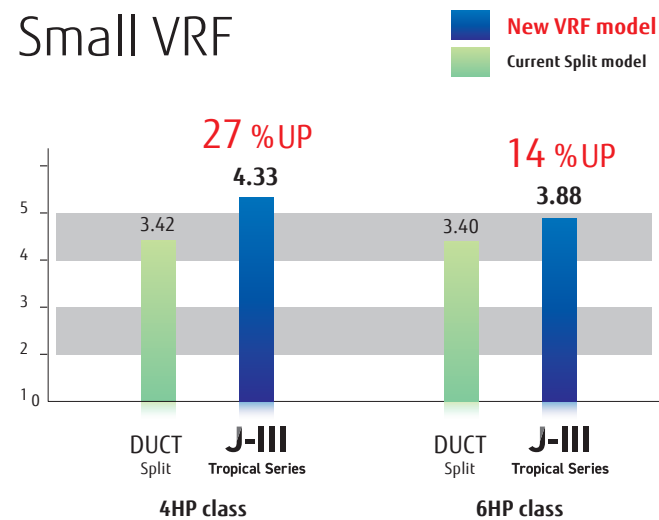
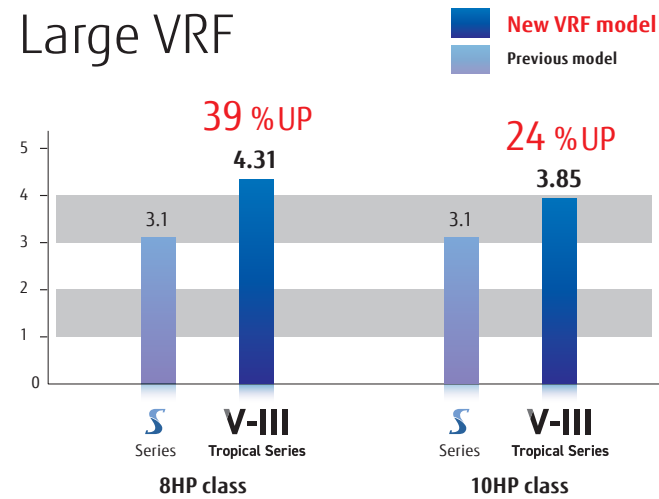

Operation Performance is Efficiently Controlled.

Room temperature set point limitation

The minimum and maximum temperature ranges can be limited, which provide further energy saving while maintaining the comfort of the occupants.

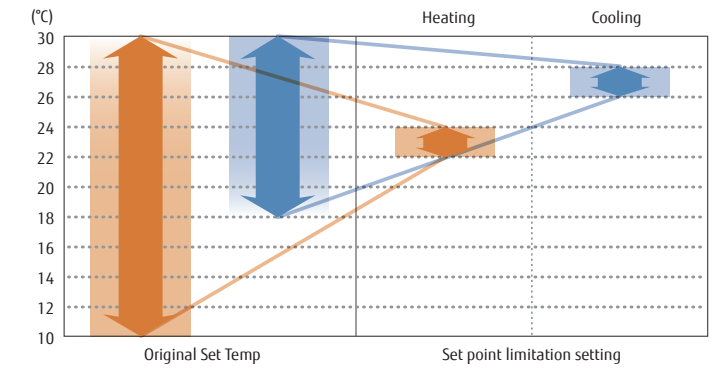

Auto-off timer

New wired remote controller is equipped with an OFF timer function that automatically stops operation when a fixed time has elapsed from the start of operation. This prevents waste of energy. Furthermore a new wired remote controller can set up the interval of time in case operation stops.

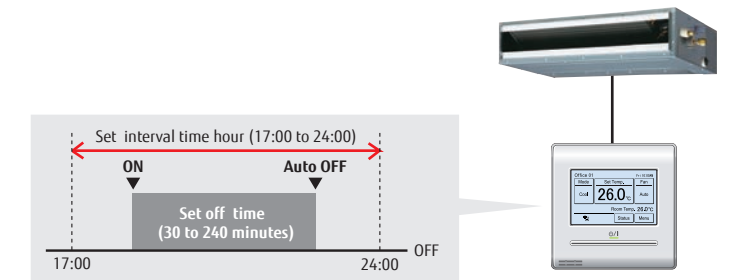

Energy saving management

A variety energy saving operations can be set and managed depending on the season, weather, and time period. Excellent energy saving operation is performed by using System Controller.

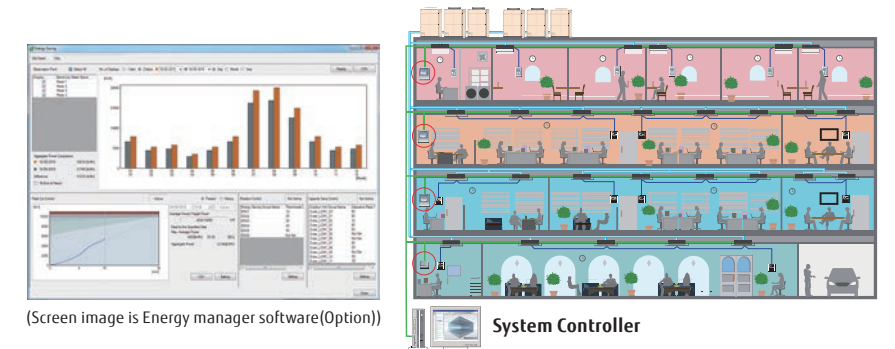

Capacity limit operation

Operation capacity can be set in 5 steps for rated capability. The power consumption at peak is cut down and the maximum load is suppressed.

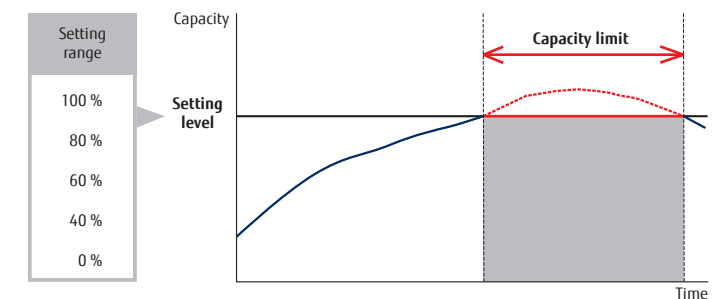

HIGH RELIABILITY



Heavy anti-corrosion treatment design

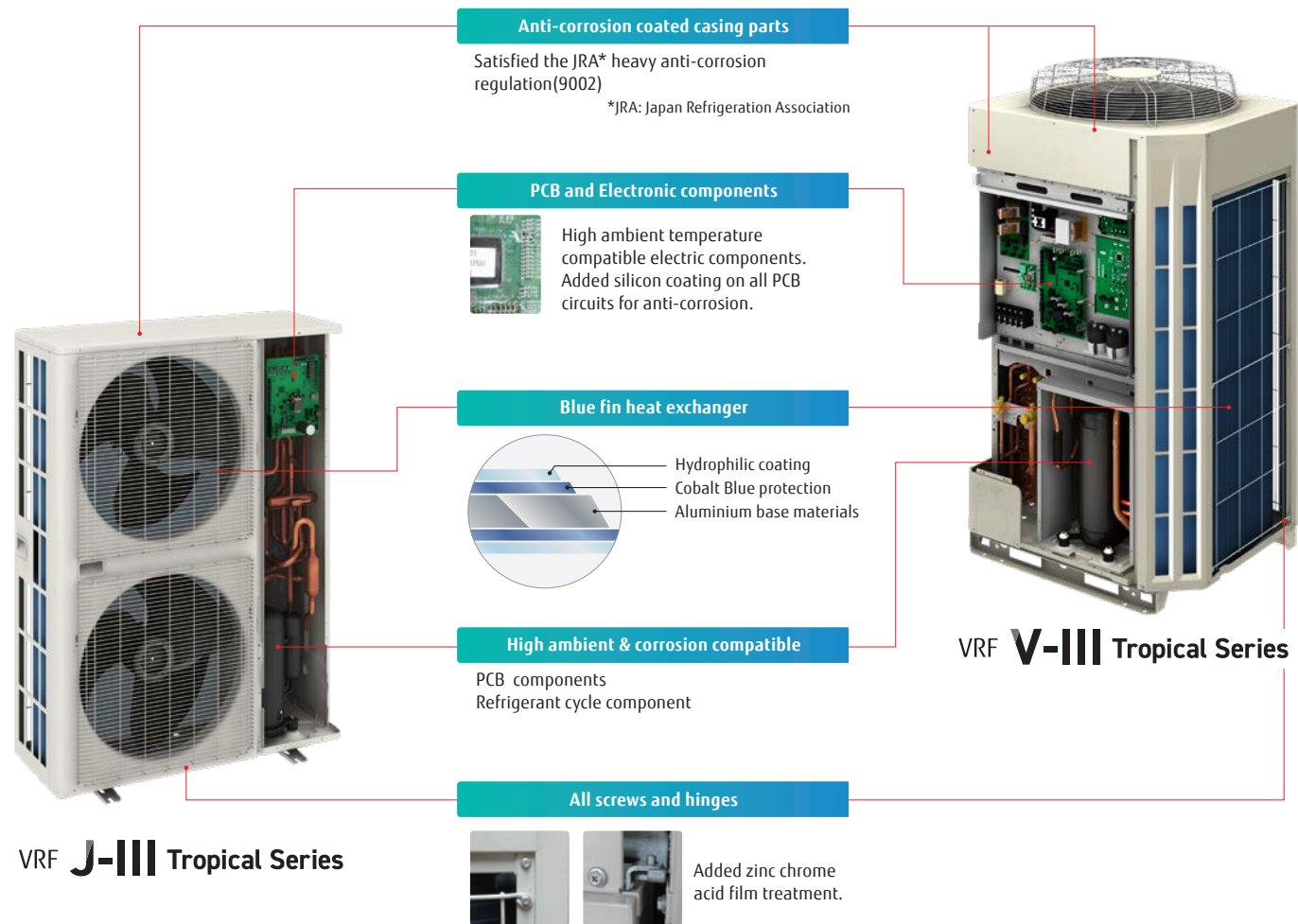

Take special notice of the following in order to enhance the anti-corrosion effect.

- Keep the unit free of direct sea breeze as much as possible by installing a windshield plate or placing the unit on the leeward side of the building.
- Arrange the unit so that any salt attached to the enclosure can be washed away by rain.
- Any water left on the bottom of the outdoor unit can increase corrosion. To prevent interference with the water drain, be careful of the tilting angle of the unit.
- Wash the enclosure regularly with water to remove any salt attached.
- Repair any damages on the unit (i.e. scratches) caused during installation or maintenance.
- Check the condition of the unit regularly. (If necessary, retreat the unit for anti-corrosion or make parts replacements.)
- Make sure the drainage is secured at the foundation.

Life-extending operation

Outdoor unit rotational operation
The compressor starting order is rotated so that the running time is shared.

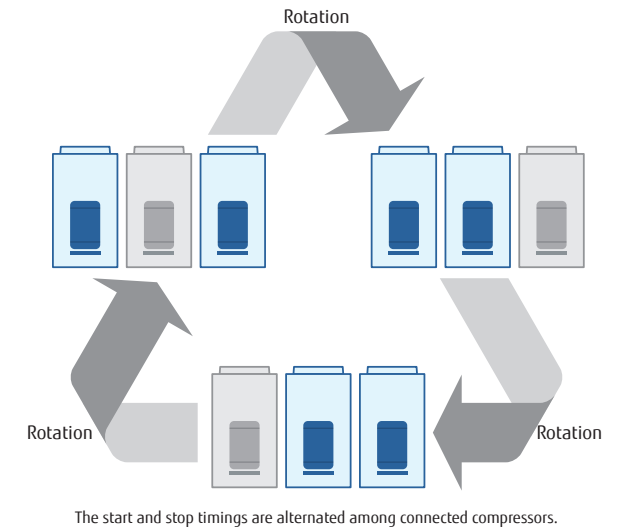

Backup operation

If one compressor fails, backup operation will be performed by the remaining compressors*.

NOTE: Need to change the Outdoor unit setting in order to perform the Backup Operation

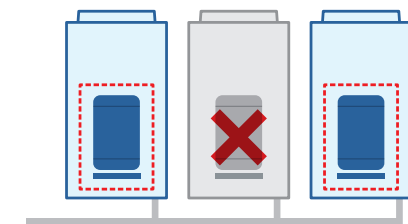

Advanced refrigerant control

Innovative compressor control logic has been introduced in order to balance the refrigerant mass flow rate of each outdoor unit by controlling the inverter speed.

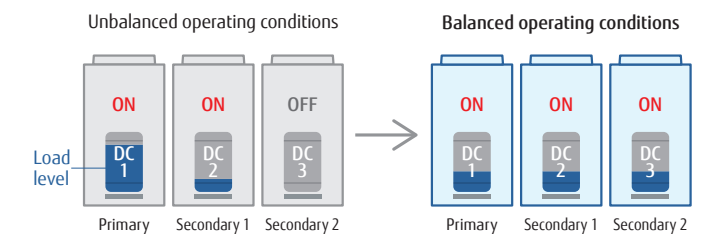

Liquid flow back protection

By adopting a large sized accumulator, the not completely vapourised refrigerant stays inside of the accumulator to ensure no liquid refrigerant is being fed into the compressor.

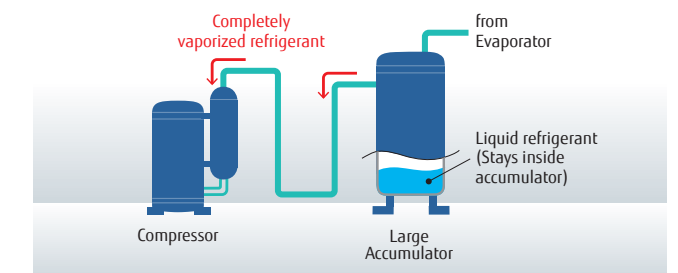

Oil Recovery operation

Periodic oil recovery operation is done automatically in order to feed back oil from the indoor unit to compressor.

DESIGN FLEXIBILITY



Overall piping length 1,000 m
(For V-III tropical)

Total pipe length
1,000 m maximum

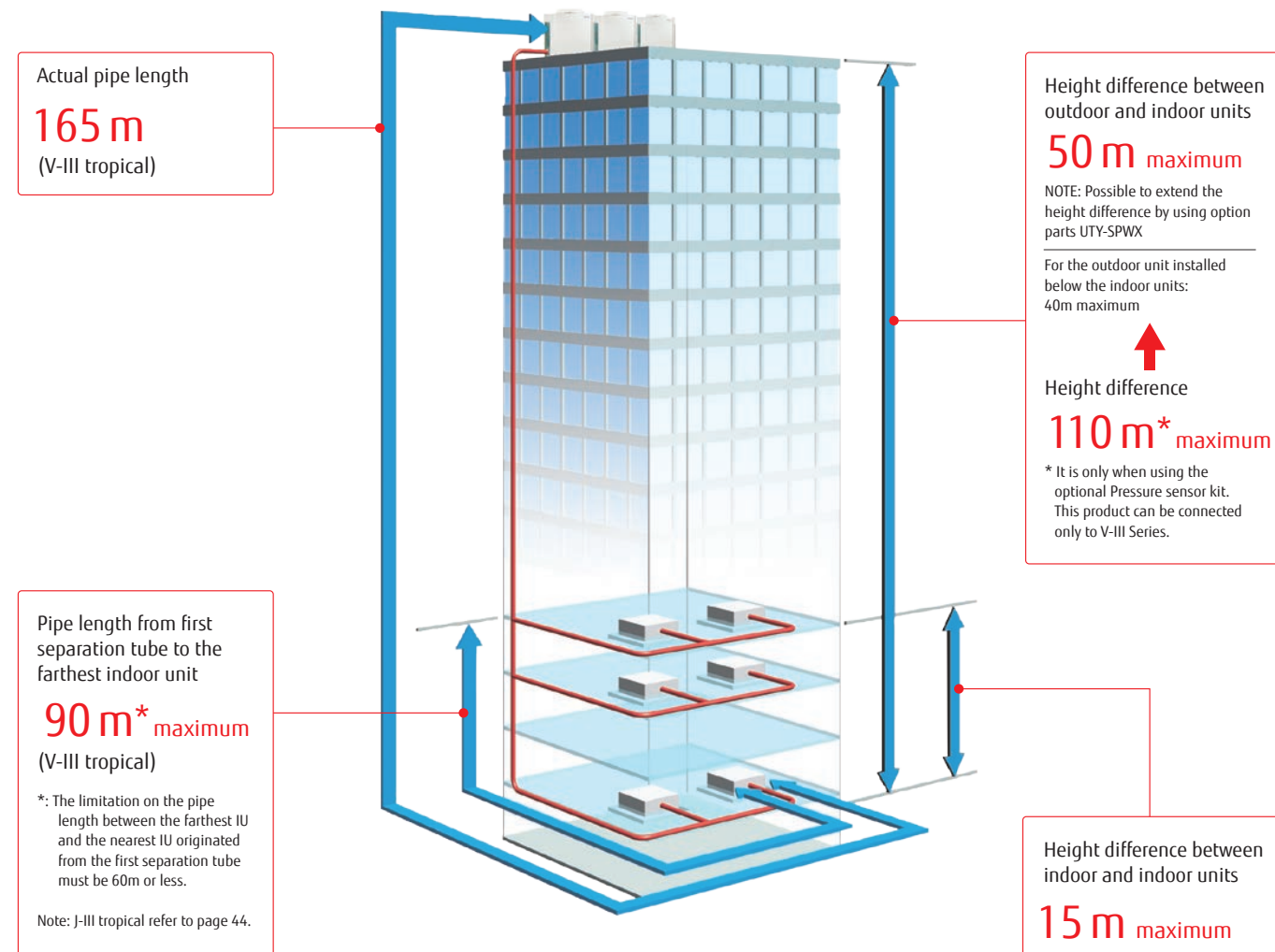

High static pressure

The outdoor unit can have a condenser hood easily connected with a static pressure of 82Pa. This allows outdoor units to be installed within plant rooms in high rise buildings.

Powerful discharge air prevents a short-circuit.

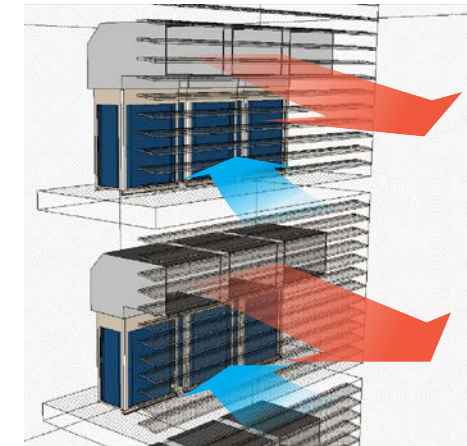

82 Pa
(V-III tropical)

Previous model

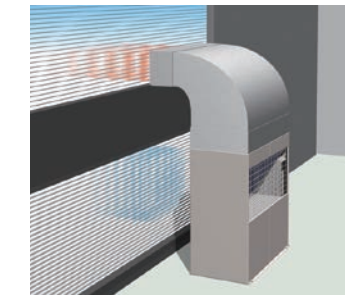

V-III tropical

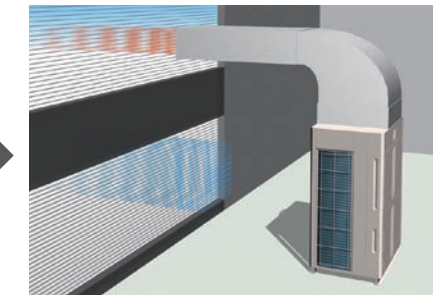

Large diameter fan and DC motor has been utilized allowing an external static pressure of 82Pa. This is approximately 2.6 times greater than the previous model.

High capacity connection

VRF V-III Tropical Series

8HP-48HP
32models



Connectable indoor unit capacity range
50 % to 130 %

Connectable indoor unit number
up to 55

VRF J-III Tropical Series

4HP-6HP
6models



Connectable indoor unit capacity range
50 % to 130 %

Connectable indoor unit number
up to 9

High ambient operation design



Installation in extreme temperature conditions is possible due to an increase in operational range.

VRF V-III Tropical Series

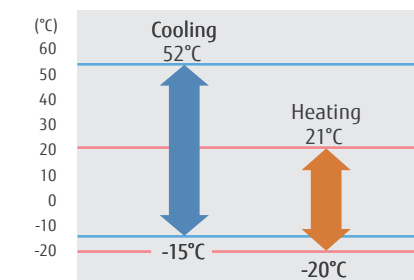

VRF J-III Tropical Series

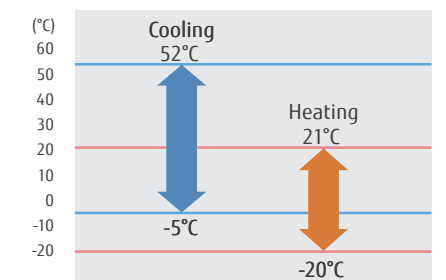

*. Note : When a multiple outdoor unit connection is used, operating range is from -5°C to 52°C in cooling.

MORE COMFORT



Precision refrigerant flow control

Precise and smooth refrigerant flow control is achieved by using a DC Inverter control in conjunction with individual indoor unit electronic expansion valve control. This allows high precision comfortable temperature control of $\pm 0.5^{\circ}\text{C}$.

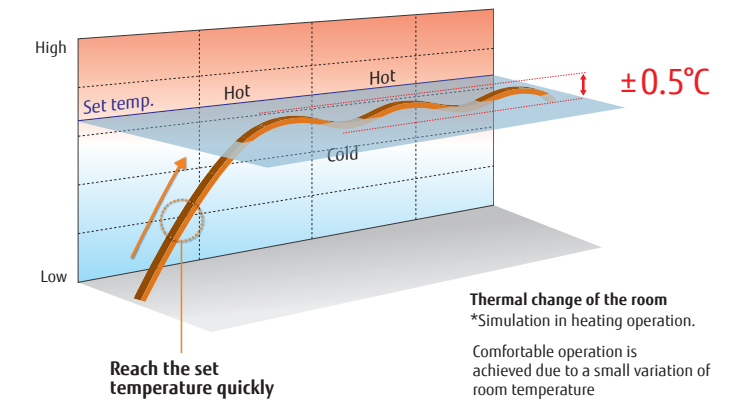

Powerful cooling capacity design

High cooling power has been realized by adopting large heat exchanger, high capacity DC inverter compressor, sub-cooler equipment, etc.

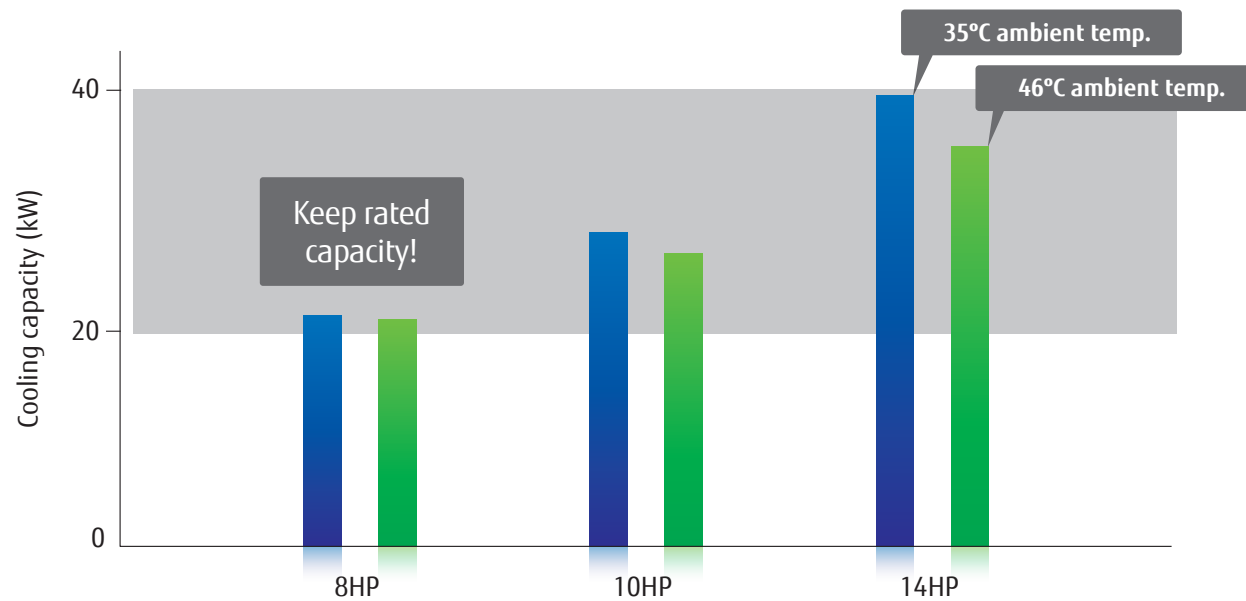

Quiet operation

Low noise mode

Two low noise modes can be selected automatically by quiet priority setting and capacity priority setting depending on the indoor environment and outside temperature load. This feature can be controlled via outdoor unit external input and/or system controller.

Quiet priority setting

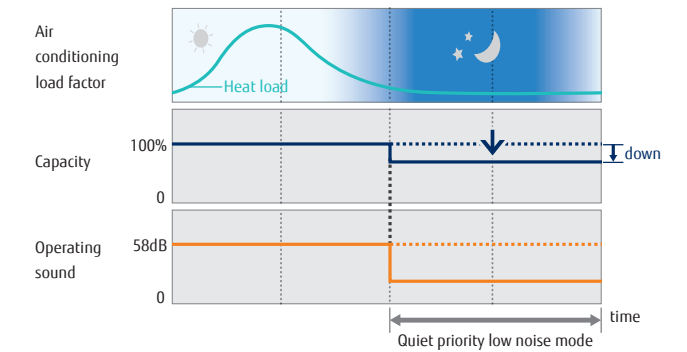

Capacity priority setting

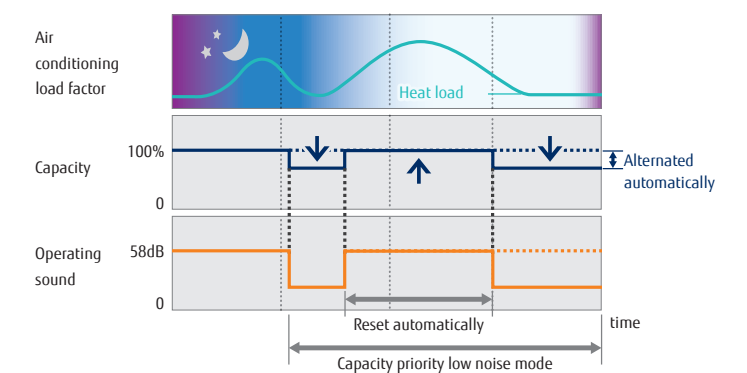

Touch Panel Wired Remote Controller

The new wired remote controller has an easy to use LCD touch panel. This new controller has a back light function and can easily control the air conditioner which provides a better energy saving operation of the air conditioner.

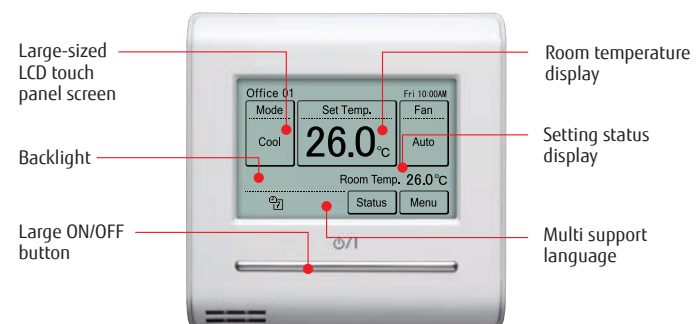

Non-stop oil recovery operation

A comfortable room condition is maintained during oil recovery mode because the product continues to operate without stopping the cooling or heating operation.

*: VRF VR-II Series is not available.

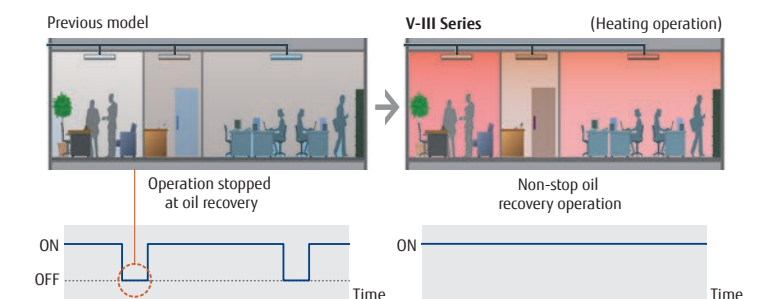

EASY INSTALLATION



Easily transported

A lifting strap can be hooked onto an outdoor unit
Design of outdoor unit allows for lifting straps to be used

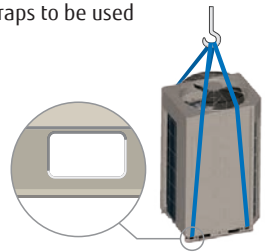

Transportable by forklift
The outdoor unit can be lifted and transported by forklift.

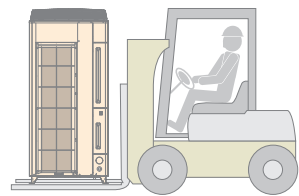

Fits into a small elevator.

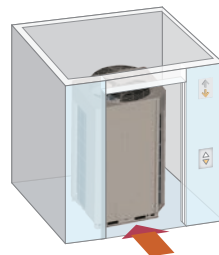

Easy access

The removable L-shaped front panel provides more room for installation and service work. Multiple installations can be performed easily and efficiently even in tight spaces.

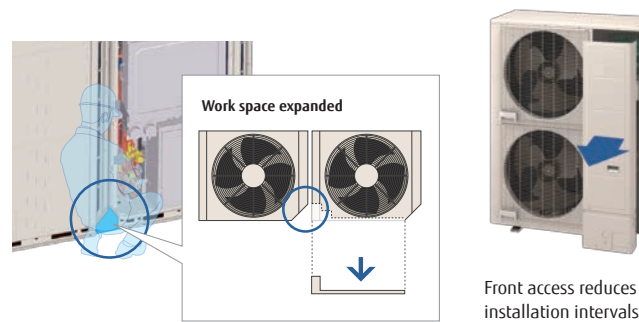

Flexible piping connection

Piping and wiring can be accessed from the front, left, right, and bottom.



Simple wiring work

Installation of the wiring systems is made easier as the communication wiring can be installed continuously between the indoor and outdoor.

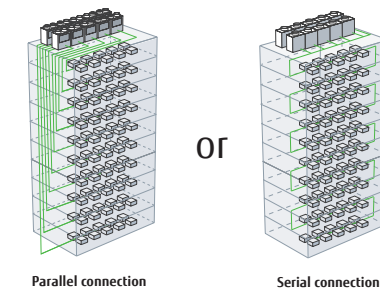

Maximum wiring length: **3,600 m**

Note: The automatic address setting is not available on a serially connected multiple refrigerant system.

Easy evacuation - using vacuum mode function

The vacuum mode function enables all expansion valves of indoor units to be fully opened, making it easy to evacuate all the air inside pipe lines and indoor units.

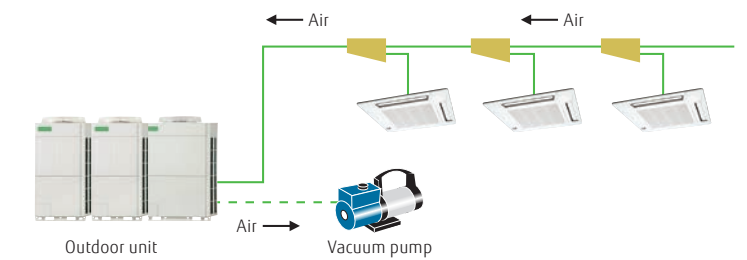

Automatic address setting

The address of the indoor unit and signal amplifier can be set through the automatic function setting on the outdoor unit PCB.

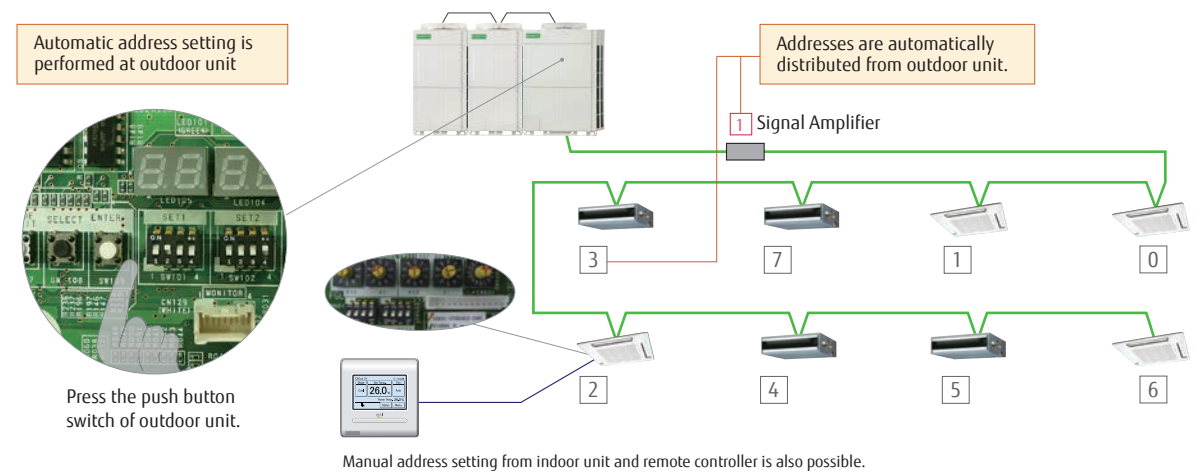

Easy commissioning by Service Tool

• Service Tool (UTY-ASGXZ1)

The Service Tool checks the refrigerant temperature and pressure, and the operating status of the electronic expansion valves, making it easy to determine if the units are connected properly.



NEW • Central Remote Controller (UTY-DCGGZ3)

After the VRF system has been installed. Conveniently, the "test run" required to verify proper system operation can be performed from a nearby Central RC.



EASY SERVICE & MAINTENANCE



Design for Easy Maintenance

7 segment LED is used to make it easy to check the details about the function setting status, refrigerant temperature, pressure, compressor operation time, and other factors for each model to make it easy to perform self-diagnostics.



Easy to read 7-segment LED : Confirm detailed operational and error status without using any specific equipment.

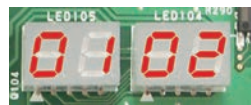

7-segment LED

- Operation mode status
- Discharge temperature/Pressure status
- Compressor operation indication
- Address/type/number of outdoor unit

Movable PCB panel
Easier for maintenance work behind the PCB



Error status can be checked easily via the indoor unit wired controller

An error code is displayed on a liquid crystal screen.

Wired Remote Controller

Simple Remote Controller

Wired Remote Controller (Touch panel)

No.	Date	Time	Address	Code
1	2012/ 8/ 1	11:00AM	002-01	143
2	2012/ 7/30	2:53AM	002-02	143
3	2012/ 7/28	10:55AM	002-02	143
4	2012/ 7/28	11:00AM	002-01	141
5	2012/ 7/22	11:00AM	002-01	141
6	2012/ 7/21	11:00AM	002-01	141

Error status can be checked easily by outdoor unit display

88 40 Error and quantity annunciation

88 88 Error code

AA 13 Abnormal indoor unit address

Error diagnosis by Service Tool

Connection to Service Tool

- Detail operation status and recent error history can be checked and analyzed by using the Service Tool.
- Last 5 min. operation memory can be also be recorded.

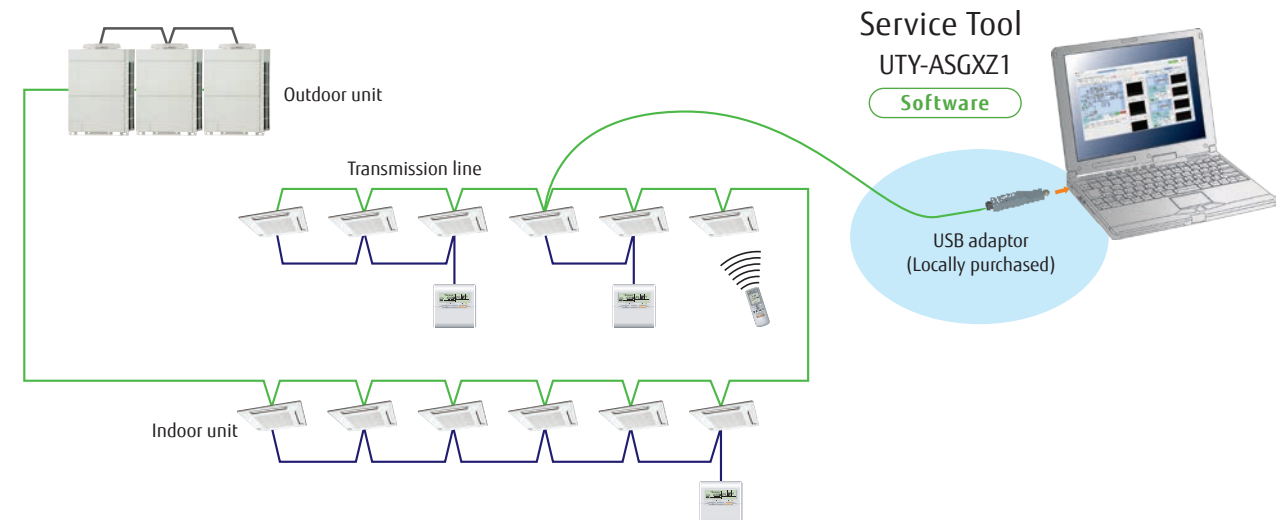

Remote monitoring

The Web Monitoring system allows you to view system operation anytime over the internet, ensuring issue free operation. The operating VRF network system in the building can be monitored real time over the Internet.

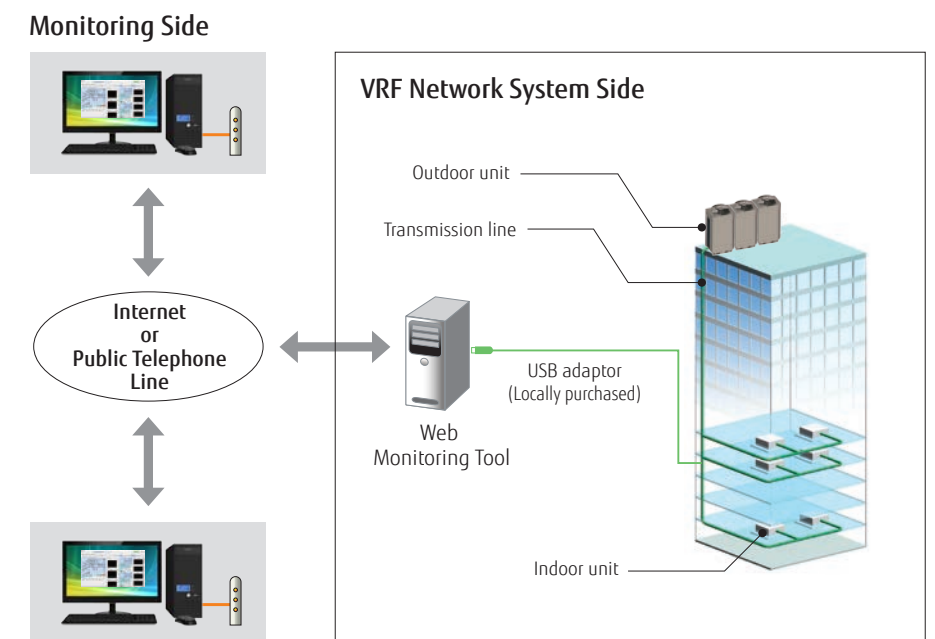

VRF OUTDOOR UNITS

VRF LINE-UP

HEAT PUMP TYPE J-III TROPICAL Series

HEAT PUMP TYPE V-III TROPICAL Series































The VRF (V-III tropical & J-III tropical) has a total of 39 models to meet the building Air-conditioning requirement

VRF Systems can be designed to effectively provide an air conditioning solution from a large domestic residence through to a large scale commercial building.

VRF LINE-UP

Fujitsu General provides multi air conditioning systems for buildings VRF Series matched to the size and application of the property.

Outdoor units range

HP	4	5	6	8	10	12	14	16	18	20	22	24	26	28	30	32	34	36	38	40	42	44	46	48	
BTU/h	36,000	45,000	54,000	72,000	90,000	108,000	126,000	144,000	162,000	180,000	198,000	216,000	234,000	252,000	270,000	288,000	306,000	324,000	342,000	360,000	378,000	396,000	414,000	432,000	
Ton	3.0	3.8	4.5	6.0	7.5	9.0	10.5	12.0	13.5	15.0	16.5	18.0	19.5	21.0	22.5	24.0	25.5	27.0	28.5	30.0	31.5	33.0	34.5	36.0	
VRF J-III Tropical Series Heat Pump	High Efficiency (Single phase)	 AJH040LTAHN	 AJH045LTAHN	 AJH054LTAHN																					
	High Efficiency (3 phase)	 AJH040LETAHN	 AJH045LETAHN	 AJH054LETAHN																					
VRF V-III Tropical Series Heat Pump	Space saving			 AJS072LNTCH	 AJS090LNTCH	 AJS108LNTCH	 AJS126LNTCH	 AJS144LNTCH		 AJS180LNTCH	 AJS198LNTCH	 AJS216LNTCH	 AJS234LNTCH	 AJS252LNTCHA	 AJS270LNTCH	 AJS288LNTCH	 AJS306LNTCHA	 AJS324LNTCHA	 AJS342LNTCHA	 AJS360LNTCH	 AJS378LNTCH			 AJS432LNTCH	
	High Efficiency						 AJS144LNTCHH	 AJS162LNTCHH	 AJS180LNTCHH		 AJS216LNTCHH	 AJS234LNTCHH	 AJS252LNTCHH	 AJS270LNTCHH	 AJS288LNTCHH	 AJS306LNTCHH	 AJS324LNTCHH	 AJS342LNTCHH	 AJS360LNTCHH	 AJS378LNTCHH	 AJS396LNTCHH	 AJS414LNTCHH			



HEAT PUMP TYPE VRF J-III Tropical Series



Fujitsu General provides air conditioning systems for a wide range of applications from small office buildings and stores to large houses.

System Outline

High Energy Efficiency

Heat pump inverter control is used to achieve an efficient cooling and heating operation in any indoor unit combination.

Flexible systems for small- and medium-size buildings air conditioning

Space saving design and long piping design allow for flexible installation on the roofs or balconies of small- and medium-size buildings. Multiple indoor units of various capacities and types can be connected.

System configuration example

- This system is used for small and medium-sized buildings. 1 refrigerant system is used for each outdoor unit.
- Connection of multiple indoor units using separation tubes and headers.

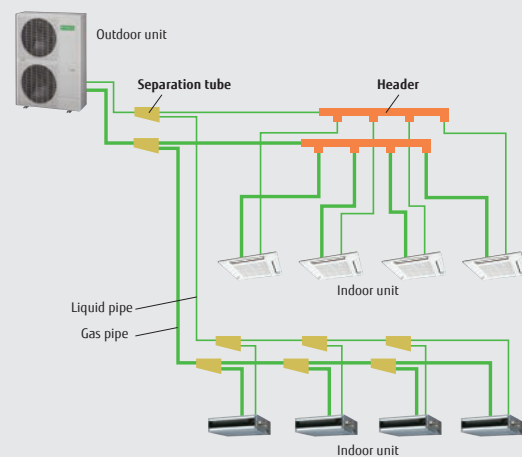

Features

Energy efficiency

Top class high COP is achieved for all models by large heat exchanger, high efficient DC twin compressor, and our own technologies.

High EER / COP

[3 phase]

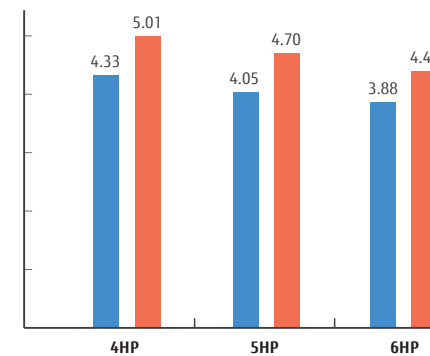

[Single phase]

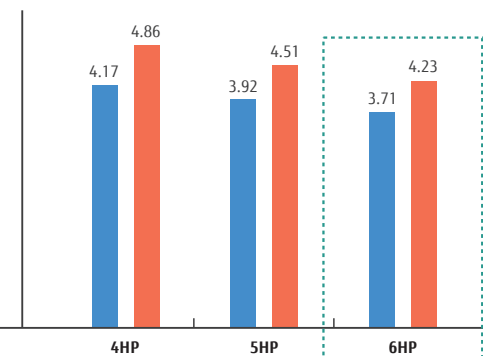

■ EER / ■ COP

6HP class

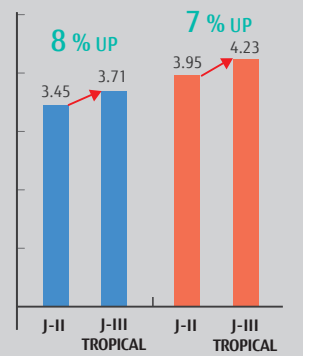

Advanced high efficiency technology



Large propeller fan

High performance and low noise realized by large propeller and optimization of angle.

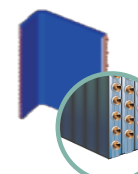

Large heat exchanger

Heat exchange performance is substantially improved by mounting of 3-row large heat exchanger.



Subcool heat exchanger

Cooling performance is improved by mounting of dual tube heat exchanger.

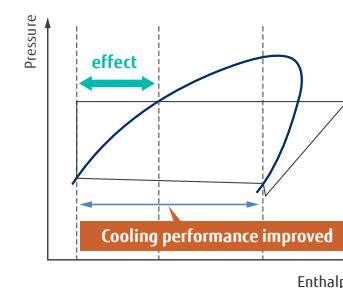

All Inverter



INVERTER control PCB

Efficiency is improved by mounting of new active filter module.



INVERTER fan motor

Miniaturized, low noise, high efficiency, multi-stage DC fan motor is mounted.



INVERTER Compressor

Efficiency in all load regions is good. Especially good performance from low to medium at normal operation.

Made in JAPAN

Long piping capability

Our advanced refrigerant control technology allows us to achieve a total refrigerant piping length of 180 m. This opens up new possibilities in system design.

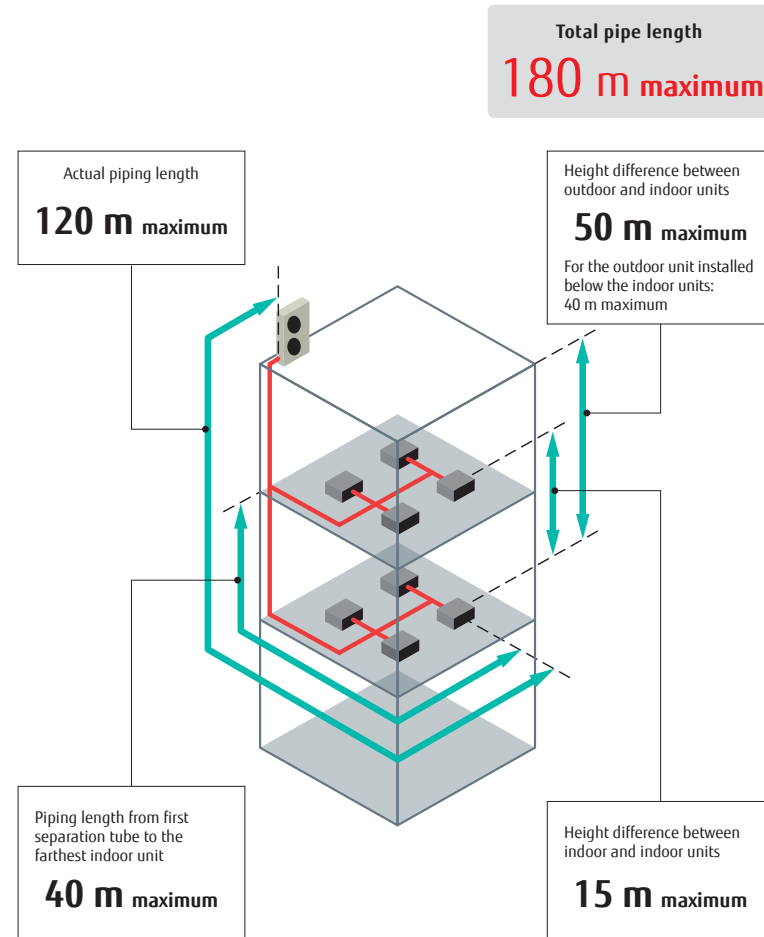

Specifications

		HP	4	5	6	4	5	6
Rating Capacity range	Btu/h		36,000	45,000	54,000	36,000	45,000	54,000
	Ton		3.0	3.8	4.5	3.0	3.8	4.5
Model name			AJH040LBTAHN	AJH045LBTAHN	AJH054LBTAHN	AJH040LETAHN	AJH045LETAHN	AJH054LETAHN
Maximum Connectable Indoor Unit			1-7	1-8	1-9	1-7	1-8	1-9
Power source			Single phase, 220-240V, 60Hz			3 phase, 380-415V, 60Hz		
Capacity	Cooling(T1/T3)	kW	12.1/10.3	14.0/11.1	15.5/11.5	12.1/10.3	14.0/11.1	15.5/11.5
	Heating	kW	13.6	16.0	18.0	13.6	16.0	18.0
Input power	Cooling(T1/T3)	Btu/h	41,000/35,000	47,500/37,800	52,500/39,000	41,000/35,000	47,500/37,800	52,500/39,000
	Heating	Btu/h	46,000	54,500	61,000	46,000	54,500	61,000
EER	Cooling(T1/T3)	W/W	4.17/2.97	3.92/2.95	3.71/2.94	4.33/3.13	4.05/3.11	3.88/3.10
	Heating	W/W	4.86	4.51	4.23	5.01	4.70	4.41
COP	Cooling(T1/T3)	Btu/h/W	14.15/10.10	13.30/10.05	12.60/9.95	14.70/10.60	13.75/10.60	13.15/10.50
	Heating	Btu/h/W	16.45	15.35	14.30	17.00	16.00	14.95
Air flow rate	High	m ³ /h(l/s)	6,200(1,722)	6,400(1,778)	6,900(1,916)	6,200(1,722)	6,400(1,778)	6,900(1,916)
Sound pressure level	Cooling	dB (A)	50	51	53	50	51	53
	Heating	dB (A)	52	53	55	52	53	55
Net Dimensions	Height	mm	1,334	1,334	1,334	1,334	1,334	1,334
	Width	mm	970	970	970	970	970	970
	Depth	mm	370	370	370	370	370	370
Net Weight	kg	120	120	120	120	120	120	
Refrigerant	Type		R410A	R410A	R410A	R410A	R410A	R410A
Connection pipe diameter	Liquid	mm	9.52	9.52	9.52	9.52	9.52	9.52
	Gas	mm	15.88	15.88	19.05	15.88	15.88	19.05
Operating range	Cooling	°CDB	-5 to 52	-5 to 52	-5 to 52	-5 to 52	-5 to 52	-5 to 52
	Heating	°CDB	-20 to 21	-20 to 21	-20 to 21	-20 to 21	-20 to 21	-20 to 21

Note: Specifications are based on the following conditions.
 Cooling(T1): Indoor temperature of 27°CDB / 19°CWB, and outdoor temperature of 35°CDB / 24°CWB
 Cooling(T3): Indoor temperature of 29°CDB / 19°CWB, and outdoor temperature of 46°CDB / 24°CWB
 Heating: Indoor temperature of 20°CDB / (15°CWB), and outdoor temperature of 7°CDB / 6°CWB.
 Pipe length: 7.5 m. Height difference between outdoor and indoor unit: 0 m.

Dimensions

Models : AJH040LBTAHN / AJH045LBTAHN / AJH054LBTAHN / AJH040LETAHN / AJH045LETAHN / AJH054LETAHN

(Unit : mm)

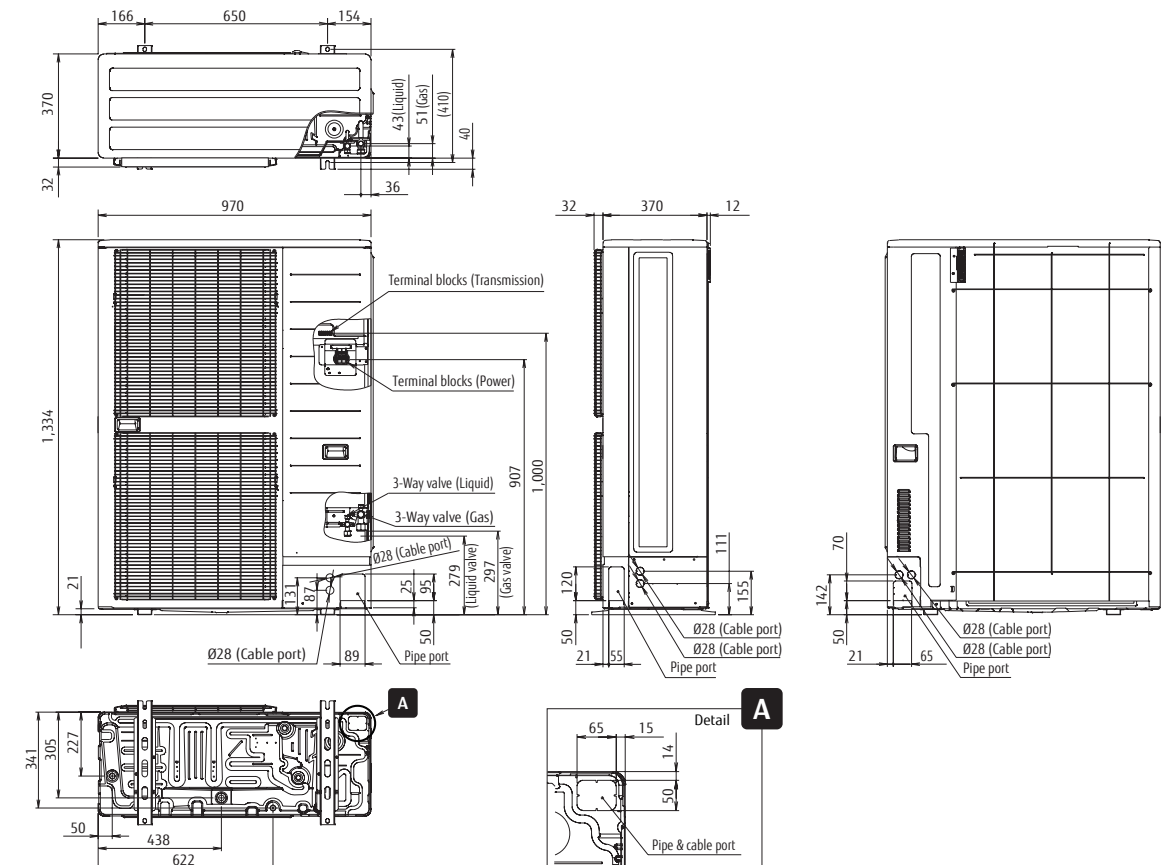

Non-stop oil recovery operation

A comfortable room condition is maintained during oil recovery mode because the product continues to operate without stopping the cooling or heating operation.

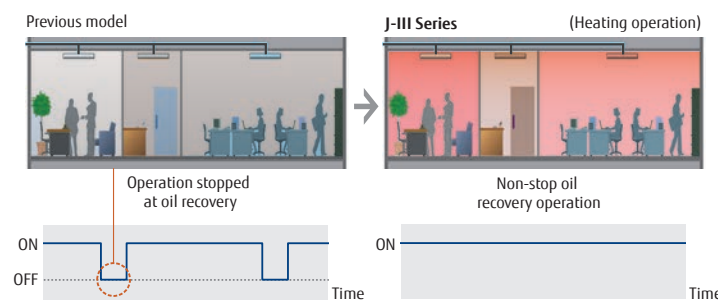

Easier Installation

Connection check function : Possible to confirm whether wiring connection and address setting are correct by a quick check run function.

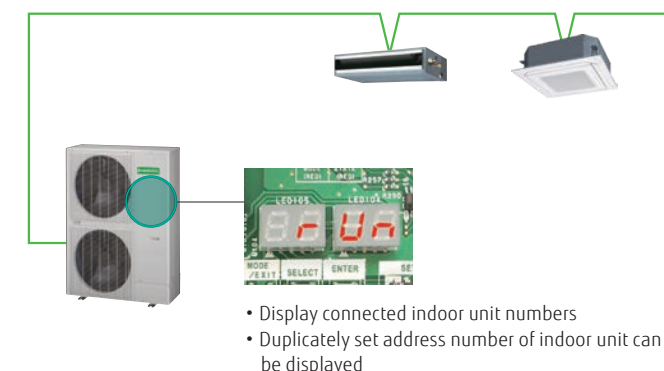

HEAT PUMP TYPE

VRF V-III Tropical Series



Fujitsu General tropical VRF is designed for tropical weather. Extensive lineup from 8HP to 54HP in 2HP increment connectable indoor unit capacity ratio up to 130%

System Outline

High ambient operation design

Possible to operate cooling up to 52°C outdoor temperature

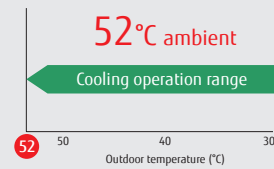

Powerful cooling capacity design

Keeping high cooling power at even high ambient temperature

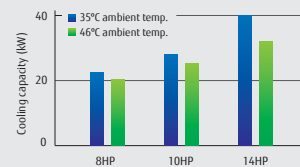

Anti-corrosion treatment design

All metallic and PCB components are protected against corrosion



System configuration example

- This system is used for medium-sized and large buildings. Connecting each outdoor unit makes it possible to create a high-capacity system.
- Connection of multiple indoor units using separation tubes and headers.

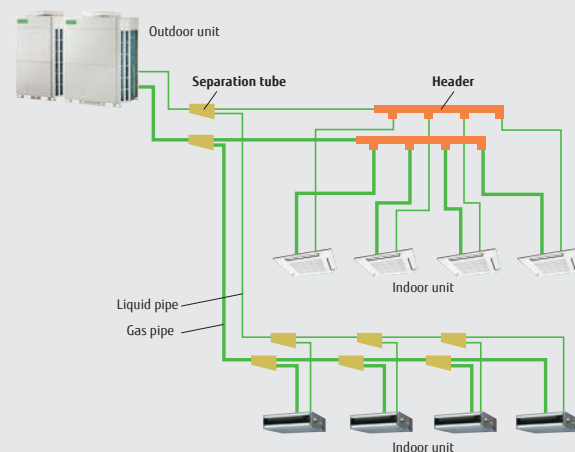

Features

Energy efficiency

Top class high COP is realized for all combinations by our unique heat exchanger structure, high efficient DC twin compressor, and other our own technologies.

Space saving combination

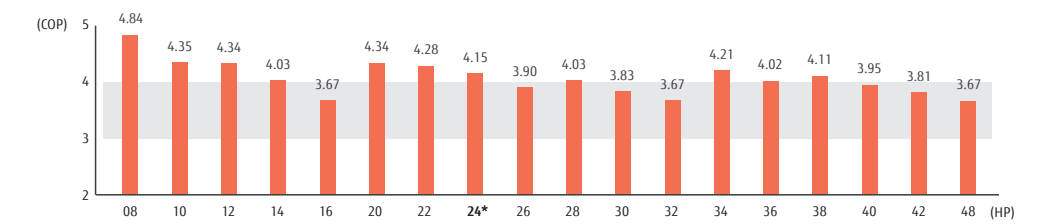

Energy efficiency combination

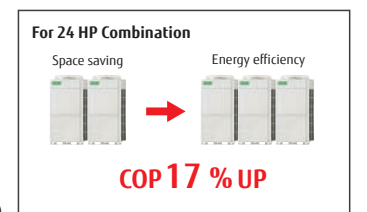
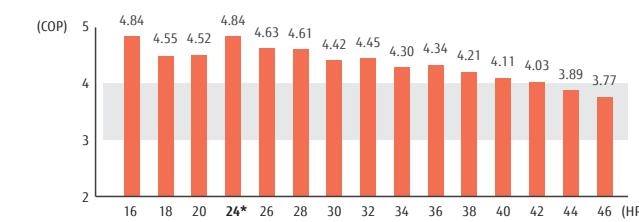

Energy saving technology that boosted operation efficiency



Powerful large propeller fan

By using CFD*1 technology, a newly designed fan achieves high performance and low noise operation.
*1. CFD = Computational Fluid Dynamics



3 phase DC fan motor

Efficiency is substantially improved by high efficient motor with sophisticated driver control. In addition, low noise is realized by DC fan motor.



Sine-wave DC inverter control

High efficiency is realized by adoption of reduced switching loss IPM.



High efficient & Large capacity DC inverter compressor

Large capacity high efficient DC twin rotary compressor with 0.1Hz steps compressor speed control

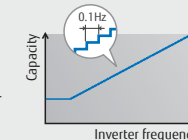

Subcool heat exchanger

High Heat Exchange efficiency is achieved by using an internal projection shape double pipe construction.



4-face heat exchanger

Heat exchange efficiency is significantly improved by the introduction of a new 4-face heat exchanger that increases effective surface area.

Front intake port (corner cut air inhaling structure)

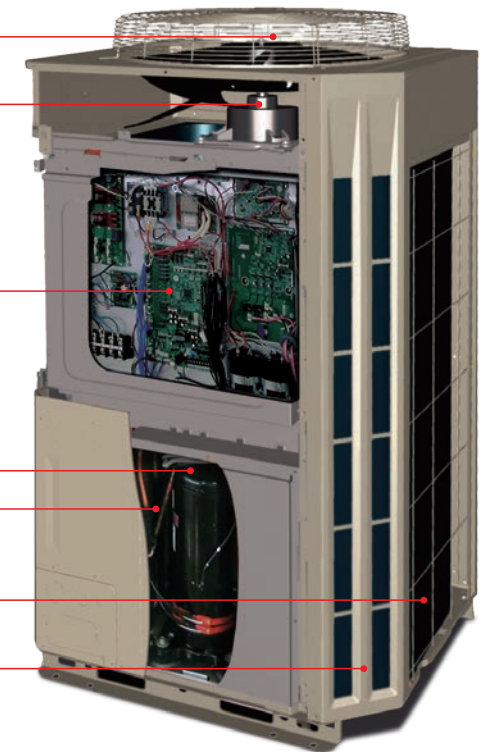

Advanced energy saving control

Multiple outdoor operation control

This control method operates all compressors at part load and distributes refrigerant to all heat exchangers to improve the overall system efficiency.

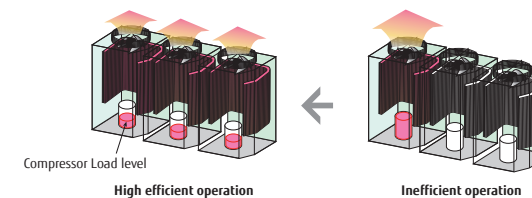

Heat exchanger refrigerant control



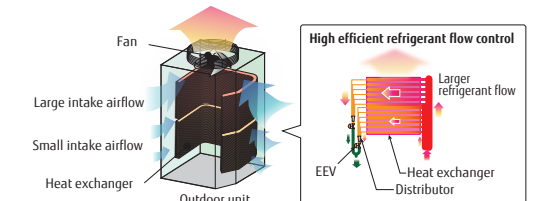













The efficiency of the top and bottom heat exchanger in the outdoor unit has been improved by adopting an optimum refrigerant path control.

















Outdoor units lineup

• Combinations other than the followings are not recommended.

Space saving combinations

72,000Btu/h (8HP)  AJS072LNTCH UNIT : AJS072LNTCH	90,000Btu/h (10HP)  AJS090LNTCH UNIT : AJS090LNTCH	108,000Btu/h (12HP)  AJS108LNTCH UNIT : AJS108LNTCH	126,000Btu/h (14HP)  AJS126LNTCH UNIT : AJS126LNTCH	144,000Btu/h (16HP)  AJS144LNTCH UNIT : AJS144LNTCH
180,000Btu/h (20HP)  AJS180LNTCH UNIT : AJS090/090LNTCH	198,000Btu/h (22HP)  AJS198LNTCH UNIT : AJS126/072LNTCH	216,000Btu/h (24HP)  AJS216LNTCH UNIT : AJS126/090LNTCH	234,000Btu/h (26HP)  AJS234LNTCH UNIT : AJS144/090LNTCH	252,000Btu/h (28HP)  AJS252LNTCHA UNIT : AJS126/126LNTCH
270,000Btu/h (30HP)  AJS270LNTCH UNIT : AJS144/126LNTCH	288,000Btu/h (32HP)  AJS288LNTCH UNIT : AJS144/144LNTCH	306,000Btu/h (34HP)  AJS306LNTCHA UNIT : AJS126/090/090LNTCH	324,000Btu/h (36HP)  AJS324LNTCHA UNIT : AJS144/090/090LNTCH	342,000Btu/h (38HP)  AJS342LNTCHA UNIT : AJS126/126/090LNTCH
360,000Btu/h (40HP)  AJS360LNTCH UNIT : AJS144/126/090LNTCH	378,000Btu/h (42HP)  AJS378LNTCH UNIT : AJS144/144/090LNTCH	432,000Btu/h (48HP)  AJS432LNTCH UNIT : AJS144/144/144LNTCH		

Energy efficiency combinations

144,000Btu/h (16HP)  AJS144LNTCHH UNIT : AJS072/072LNTCH	162,000Btu/h (18HP)  AJS162LNTCHH UNIT : AJS090/072LNTCH	180,000Btu/h (20HP)  AJS180LNTCHH UNIT : AJS108/072LNTCH	216,000Btu/h (24HP)  AJS216LNTCHH UNIT : AJS072/072/072LNTCH	234,000Btu/h (26HP)  AJS234LNTCHH UNIT : AJS090/072/072LNTCH
252,000Btu/h (28HP)  AJS252LNTCHH UNIT : AJS108/072/072LNTCH	270,000Btu/h (30HP)  AJS270LNTCHH UNIT : AJS126/072/072LNTCH	288,000Btu/h (32HP)  AJS288LNTCHH UNIT : AJS108/108/072LNTCH	306,000Btu/h (34HP)  AJS306LNTCHH UNIT : AJS126/108/072LNTCH	324,000Btu/h (36HP)  AJS324LNTCHH UNIT : AJS108/108/108LNTCH
342,000Btu/h (38HP)  AJS342LNTCHH UNIT : AJS126/108/108LNTCH	360,000Btu/h (40HP)  AJS360LNTCHH UNIT : AJS126/126/108LNTCH	378,000Btu/h (42HP)  AJS378LNTCHH UNIT : AJS126/126/126LNTCH	396,000Btu/h (44HP)  AJS396LNTCHH UNIT : AJS144/126/126LNTCH	414,000Btu/h (46HP)  AJS414LNTCHH UNIT : AJS144/144/126LNTCH

8,10HP : AJS072LNTCH / AJS090LNTCH
12,14,16HP : AJS108LNTCH / AJS126LNTCH / AJS144LNTCH



8, 10HP

12, 14, 16HP

Dimensions

8,10HP

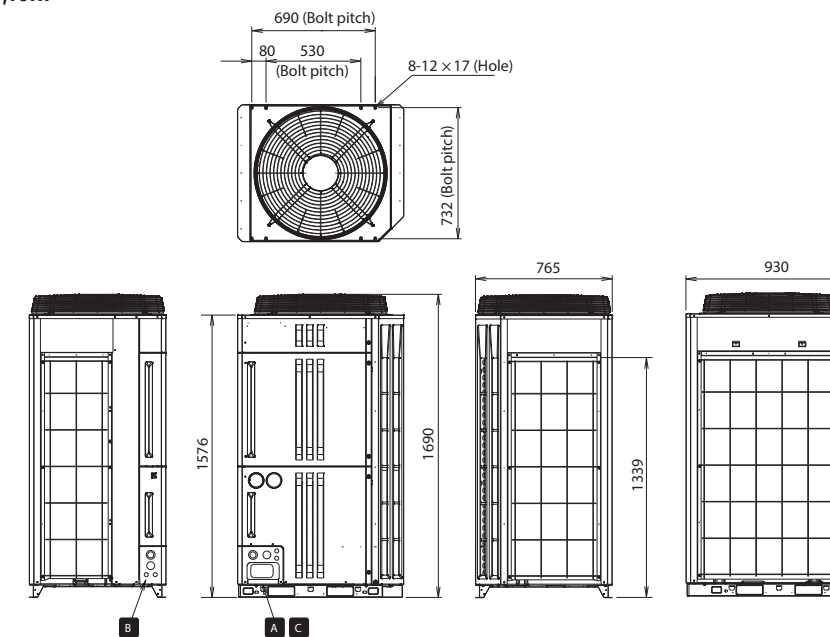

(Unit : mm)

12,14,16HP

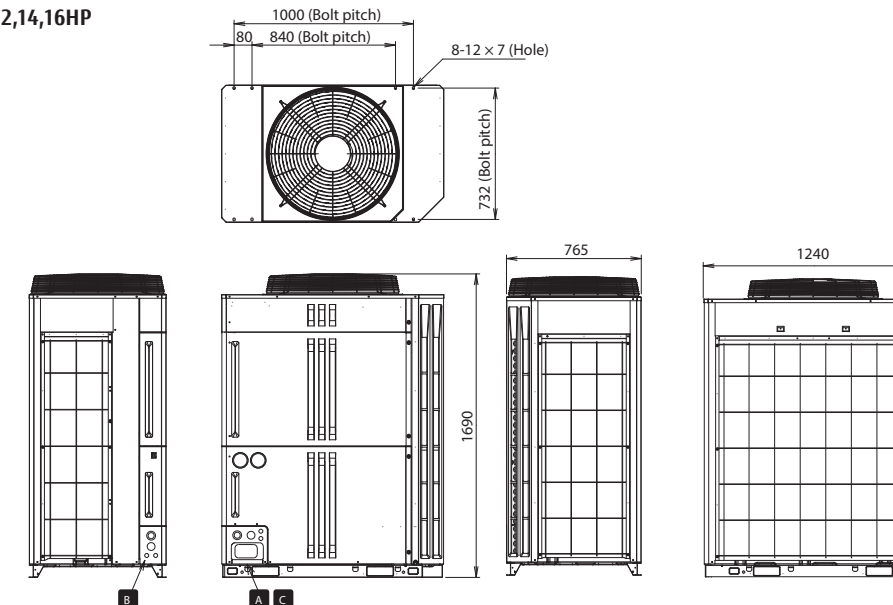

Space Saving Combination

Rating Capacity range		HP	8	10	12	14	16	20	22	24	26	28	30	32	34	36	38	40	42	48		
		Btu/h	72,000	90,000	108,000	126,000	144,000	180,000	198,000	216,000	234,000	252,000	270,000	288,000	306,000	324,000	342,000	360,000	378,000	396,000	432,000	
		Ton	6.0	7.5	9.0	10.5	12.0	15.0	16.5	18.0	19.5	22.5	24.0	25.5	27.0	28.5	31.5	33.0	34.5	36.0		
Model name			AJS072LNTCH	AJS090LNTCH	AJS108LNTCH	AJS126LNTCH	AJS144LNTCH	AJS180LNTCH	AJS198LNTCH	AJS216LNTCH	AJS234LNTCH	AJS252LNTCH	AJS270LNTCH	AJS288LNTCH	AJS306LNTCH	AJS324LNTCH	AJS342LNTCH	AJS360LNTCH	AJS378LNTCH	AJS396LNTCH	AJS432LNTCH	
Unit 1			AJS072LNTCH	AJS090LNTCH	AJS108LNTCH	AJS126LNTCH	AJS144LNTCH	AJS180LNTCH	AJS198LNTCH	AJS216LNTCH	AJS234LNTCH	AJS252LNTCH	AJS270LNTCH	AJS288LNTCH	AJS306LNTCH	AJS324LNTCH	AJS342LNTCH	AJS360LNTCH	AJS378LNTCH	AJS396LNTCH	AJS432LNTCH	
Unit 2			AJS072LNTCH	AJS090LNTCH	AJS108LNTCH	AJS126LNTCH	AJS144LNTCH	AJS180LNTCH	AJS198LNTCH	AJS216LNTCH	AJS234LNTCH	AJS252LNTCH	AJS270LNTCH	AJS288LNTCH	AJS306LNTCH	AJS324LNTCH	AJS342LNTCH	AJS360LNTCH	AJS378LNTCH	AJS396LNTCH	AJS432LNTCH	
Unit 3			AJS072LNTCH	AJS090LNTCH	AJS108LNTCH	AJS126LNTCH	AJS144LNTCH	AJS180LNTCH	AJS198LNTCH	AJS216LNTCH	AJS234LNTCH	AJS252LNTCH	AJS270LNTCH	AJS288LNTCH	AJS306LNTCH	AJS324LNTCH	AJS342LNTCH	AJS360LNTCH	AJS378LNTCH	AJS396LNTCH	AJS432LNTCH	
Maximum Connectable Indoor Unit			13	16	19	23	26	33	36	40	43	47	50	53	55	55	55	55	55	55	55	
Indoor unit connectable capacity		Cooling	kW	11.2-29.1	14-36.4	16.8-43.5	20-52	22.5-58.5	28-72.8	31.2-81.1	34-88.4	36.5-94.9	40-104	42.5-110.5	45-117	48-124.8	50.5-131.3	54-140.4	56.5-146.9	59-153.4	67.5-175.5	
Power source		3 phase, 380-415V, 60Hz										3 phase, 380-415V, 60Hz										
T1 condition	Capacity	Cooling	kW	22.4	28.0	33.5	40.0	45.0	56.0	62.4	68.0	73.0	80.0	85.0	90.0	96.0	101.0	108.0	113.0	118.0	135.0	
			Btu/h	76000	95000	114000	135000	152000	190000	211000	230000	270000	270000	304000	322000	340000	366000	384000	411000	429000	447000	510000
		Heating	kW	5.20	7.28	8.96	10.96	13.01	14.56	16.16	18.24	20.29	21.92	23.97	26.02	25.52	27.57	29.20	31.25	33.30	33.30	39.03
			Btu/h	17700	24600	30600	36900	44100	49200	55200	63000	70800	78600	86400	94200	92000	100000	108000	116000	124000	124000	150000
		Input power	Cooling	kW	5.17	7.25	8.65	11.17	13.63	14.50	16.34	18.42	20.88	22.34	24.80	27.26	25.67	28.13	29.59	32.05	34.51	40.89
	Btu/h			17500	24300	29400	37200	45600	49200	55200	63000	70800	78600	86400	94200	92000	100000	108000	116000	124000	150000	
	Heating		kW	9.2	12.0	15.0	17.7	20.7	-	-	-	-	-	-	-	-	-	-	-	-	-	-
	Current	Cooling	A	9.2	12.2	14.6	18.2	21.5	-	-	-	-	-	-	-	-	-	-	-	-	-	-
			Btu/h	32.5	42.5	51.5	63.5	74.5	-	-	-	-	-	-	-	-	-	-	-	-	-	-
		Heating	kW	4.31	3.85	3.74	3.65	3.46	3.85	3.86	3.73	3.60	3.65	3.55	3.46	3.76	3.66	3.70	3.62	3.54	3.46	
Btu/h			14600	13000	12700	12300	11650	13050	13060	12610	12170	12320	11970	11680	12740	12400	12500	12220	11980	11680		
EER		Cooling	W/W	4.84	4.35	4.34	4.03	3.67	4.34	4.28	4.15	3.90	4.03	3.83	3.67	4.21	4.02	4.11	3.95	3.81	3.67	
	Btu/h/W		16.40	14.75	14.65	13.60	12.45	14.76	13.27	14.06	13.27	12.98	12.98	12.47	13.65	13.89	13.39	12.95	12.47			
	Heating	W/W	16.40	14.75	14.65	13.60	12.45	14.76	13.27	14.06	13.27	12.98	12.98	12.47	13.65	13.89	13.39	12.95	12.47			
T3 condition	Capacity	Cooling	kW	20.2	25.2	28.5	32	35.1	50.4	52.2	57.2	60.3	64.0	67.1	70.2	82.4	85.5	89.2	92.3	95.4	105.3	
			Btu/h	68000	86000	97000	109000	119000	172000	177000	195000	205000	218000	228000	238000	281000	291000	304000	314000	324000	357000	
		Heating	kW	6.73	9.20	9.34	10.70	11.82	18.40	17.43	19.90	21.02	21.40	22.52	23.64	29.10	30.22	30.60	31.72	32.84	35.46	
			Btu/h	22800	31200	31800	36300	40200	63000	60000	68000	71500	73500	78000	81000	100000	103000	105000	109000	113000	121000	
		EER	Cooling	W/W	3.00	2.74	3.05	2.99	2.97	2.74	2.99	2.87	2.87	2.99	2.98	2.97	2.83	2.83	2.92	2.91	2.90	2.97
Btu/h/W	10.10			9.30	10.35	10.15	10.05	9.35	10.15	9.80	9.75	10.19	10.12	10.07	9.66	9.63	9.93	9.90	9.87	10.07		
Power factor		%	90	92	92	92	92	92	92	92	92	92	92	92	92	92	92	92	92	92		
Air flow rate		High	m³/h	11100	11100	13000	13000	13700	11100*2	13000+11100	13000+11100	13700+11100	13000*2	13700+13000	13700*2	13000+11100*2	13700+11100*2	13000*2+11100	13700+13000+11100	13700*2+11100	13700*3	
Sound pressure level	Cooling	dB (A)	56	58	57	60	62	61	63	61	63	64	65	66	67	65	66	66	67	68	69	
			Heating	58	59	60	62	64	62	63	64	65	66	67	68	69	67	68	68	69	70	
Maximum external static pressure		Pa	82	82	82	82	82	82	82	82	82	82	82	82	82	82	82	82	82	82		
Compressor motor output		kW	7.5	7.5	11	11	11	7.5*2	11.0+7.5	11.0+7.5	11.0+7.5	11.0+7.5	11.0+7.5	11.0+7.5	11.0+7.5	11.0+7.5	11.0+7.5	11.0+7.5	11.0+7.5	11.0+7.5		
Heat exchanger fin		Blue fin	Blue fin	Blue fin	Blue fin	Blue fin	Blue fin	Blue fin	Blue fin	Blue fin	Blue fin	Blue fin	Blue fin	Blue fin	Blue fin	Blue fin	Blue fin	Blue fin	Blue fin	Blue fin		
Dimensions	Height	mm	1690	1690	1690	1690	1690	1690	1690	1690	1690	1690	1690	1690	1690	1690	1690	1690	1690	1690		
			Width	930	930	1240	1240	1240	930*2	1240+930	1240+930	1240+930	1240+930	1240+930	1240+930	1240+930	1240+930	1240+930	1240+930	1240+930	1240+930	
			Depth	765	765	765	765	765	765	765	765	765	765	765	765	765	765	765	765	765	765	
Weight		kg	255	255	279	279	279	255*2	279+255	279+255	279+255	279+255	279+255	279+255	279+255	279+255	279+255	279+255	279+255	279+255		
Refrigerant	Type	R410A	R410A	R410A	R410A	R410A	R410A	R410A	R410A	R410A	R410A	R410A	R410A	R410A	R410A	R410A	R410A	R410A	R410A			
		Charge	kg	11.7	11.7	11.8	11.8	11.8	11.7+2	11.8+11.7	11.8+11.7	11.8+11.7	11.8+2	11.8+2	11.8+2	11.8+11.7+2	11.8+11.7+2	11.8+11.7+2	11.8+11.7+2	11.8+11.7+2		
Connection pipe diameter	Liquid	mm	12.70	12.70	12.70	12.70	12.70	15.88	15.88	15.88	15.88	15.88	19.05	19.05	19.05	19.05	19.05	19.05	19.05			
			Discharge Gas	22.22	22.22	28.58	28.58	28.58	28.58	34.92	34.92	34.92	34.92	34.92	41.27	41.27	41.27	41.27	41.27			
Operating range	Cooling	°CDB	-15 to 52	-15 to 52	-15 to 52	-15 to 52	-15 to 52	-5 to 52	-5 to 52	-5 to 52	-5 to 52	-5 to 52	-5 to 52	-5 to 52	-5 to 52	-5 to 52	-5 to 52	-5 to 52	-5 to 52			
			Heating	-20 to 21	-20 to 21	-20 to 21	-20 to 21	-20 to 21	-20 to 21	-20 to 21	-20 to 21	-20 to 21	-20 to 21	-20 to 21	-20 to 21	-20 to 21	-20 to 21	-20 to 21	-20 to 21	-20 to 21		

Energy Efficiency Combination

Rating Capacity range		HP	16	18	20	24	26	28	30	32	34	36	38	40	42	44	46	
		Btu/h	144,000	162,000	180,000	216,000	234,000	252,000	270,000	288,000	306,000	324,000	342,000	360,000	378,000	396,000	414,000	
		Ton	12.0	13.5	15.0	18.0	19.5	21.0	22.5	24.0	25.5	27.0	28.5	30.0	31.5	33.0	34.5	
Model name			AJS144LNTCHH	AJS162LNTCHH	AJS180LNTCHH	AJS216LNTCHH	AJS234LNTCHH	AJS252LNTCHH	AJS270LNTCHH	AJS288LNTCHH	AJS306LNTCHH	AJS324LNTCHH	AJS342LNTCHH	AJS360LNTCHH	AJS378LNTCHH	AJS396LNTCHH	AJS414LNTCHH	
Unit 1			AJS072LNTCH	AJS090LNTCH	AJS108LNTCH	AJS126LNTCH	AJS144LNTCH	AJS180LNTCH	AJS198LNTCH	AJS216LNTCH	AJS234LNTCH	AJS252LNTCH	AJS270LNTCH	AJS288LNTCH	AJS306LNTCH	AJS324LNTCH	AJS342LNTCH	
Unit 2			AJS072LNTCH	AJS090LNTCH	AJS108LNTCH	AJS126LNTCH	AJS144LNTCH	AJS180LNTCH	AJS198LNTCH	AJS216LNTCH	AJS234LNTCH	AJS252LNTCH	AJS270LNTCH	AJS288LNTCH	AJS306LNTCH	AJS324LNTCH	AJS342LNTCH	
Unit 3			AJS072LNTCH	AJS090LNTCH	AJS108LNTCH	AJS126LNTCH	AJS144LNTCH	AJS180LNTCH	AJS198LNTCH	AJS216LNTCH	AJS234LNTCH	AJS252LNTCH	AJS270LNTCH	AJS288LNTCH	AJS306LNTCH	AJS324LNTCH	AJS342LNTCH	
Maximum Connectable Indoor Unit			26	29	33	39	43	46	50	52	55	55	55	55	55	55		
Indoor unit connectable capacity		Cooling	kW	22.4-58.2	25-65	28-72.6	33.6-87.3	36.4-94.6	39.2-101.7	42.4-110.2	44.7-116.2	48-124.6	50.3-130.6	53.5-139.1	56.8-147.5	60-156	62.5-162.5	65-169
Power source		3 phase, 380-415V, 60Hz										3 phase, 380-415V, 60Hz						
T1 condition	Capacity	Cooling	kW	44.8	50.4	55.9	67.2	72.8	84.8	89.4								

VRF INDOOR UNITS

INDOOR UNITS LINE-UP

Compact Cassette

Circular Flow Cassette

Slim Duct / Slim Concealed Floor

Medium Static Pressure Duct

High Static Pressure Duct

Large Airflow Duct

Floor / Ceiling

Ceiling

Wall Mounted (EEV Internal)































































10 Type and 55 models available to meet the requirements of any building design.

VRF indoor units were developed to be highly efficient, compact, low noise and to have user friendly operation. With a variety of indoor units and capacities available, Fujitsu General has an indoor unit to match any requirement which is easy to install and maintain. Further, a variety of options are available to achieve an air conditioning environment that is more desirable from the user's perspective.

INDOOR UNITS LINE-UP

Comprehensive range of indoor units of variety design and capacity ranges available which can be selected to suit any air conditioning needs.
10 types, 55 models, Capacity range from 7,000 Btu/h to 96,000 Btu/h

Indoor units range

Capacity range		Btu/h	7,000	9,000	12,000	14,000	18,000	24,000	30,000	34,000	36,000	45,000	54,000	60,000	72,000	90,000	96,000		
		kW	2.2	2.8	3.6	4.5	5.6	7.1	9.0	10.0	11.2	12.5	14.0	18.0	22.4	25.0	28.0		
Cassette	Compact Cassette			 AUXB09GATH	 AUXB12GATH	 AUXB14GATH	 AUXB18GATH	 AUXB24GATH											
	(Slim type)						 AUXM018GTAH	 AUXM024GTAH											
	Circular Flow (Large type)						 AUXK018GTAH	 AUXK024GTAH	 AUXK030GTAH	 AUXK034GTAH	 AUXK036GTAH	 AUXK045GTAH	 AUXK054GTAH						
Duct	Slim Duct (With drain pump)		 ARXD07GATH	 ARXD09GATH	 ARXD12GATH	 ARXD14GATH	 ARXD18GATH	 ARXD24GATH											
	Medium Static Pressure Duct							 ARXA24GBTH	 ARXA30GBTH		 ARXA36GBTH	 ARXA45GBTH							
	High Static Pressure Duct											 ARXC36GBTH			 ARXC72GBTH*1	 ARXC90GBTH*1	 ARXC96GBTH*1		
													 ARKC45GATH	 ARKC60GATH*1					
Large Airflow Duct						 ARXN18GATH*2	 ARXN24GATH*2	 ARXN30GATH*2	 ARXN34GATH*2	 ARXN36GATH*2	 ARXN45GATH*2								
Floor	Floor (Same as Ceiling models)			 ABHA12GATH	 ABHA14GATH	 ABHA18GATH	 ABHA24GATH												
	Slim Concealed Floor (Same as Slim Duct models)		 ARXD07GATH	 ARXD09GATH	 ARXD12GATH	 ARXD14GATH	 ARXD18GATH	 ARXD24GATH											
Ceiling	Ceiling			 ABHA12GATH	 ABHA14GATH	 ABHA18GATH	 ABHA24GATH	 ABHA30GATH			 ABHA36GATH	 ABHA45GATH	 ABHA54GATH						
Wall Mounted	Wall Mounted		 ASHA07GATH	 ASHA09GATH	 ASHA12GATH	 ASHA14GATH	 ASHA18GATH	 ASHA24GATH	 ASHA30GATH										

*1:ARXC60/72/90/96 cannot be connected to J-III tropical Series. *2:Large Airflow Duct can be connected to V-III tropical Series only.

Compact Cassette



2-stage turbo fan

High efficiency design by 2 stage structure

An evenly spread air distribution across the heat exchanger is possible due to the new 2 stage turbo fan which produces two separate airflow streams.

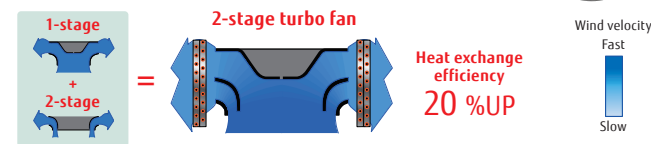

Previous turbo fan
In the case of a previous fan, the air outlet range was narrow as the airflow moved to the motor side which meant the velocity of air passing through the heat exchanger was uneven.

Quiet quality

Optimization of wing form (laminar wing type) and wing number (7 blades each)

Designed by CFD-analysis (fluid) simulations

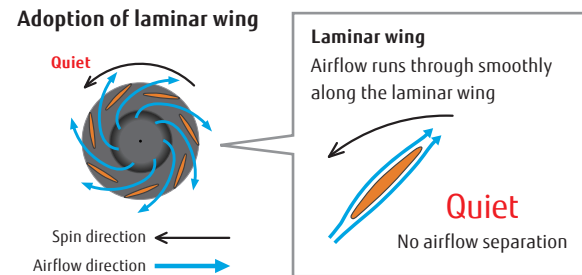

Improvement of the airflow distribution

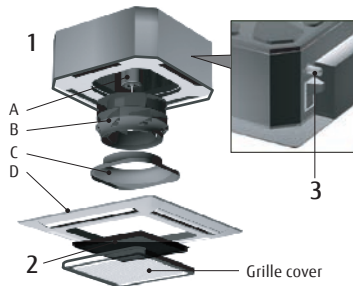

1. Maintenance of fan motor and fan

Maintenance of the fan motor and fan can be done easily after taking off the panel as the bell mouth of the fan can be removed easily.

- A : Fan motor B : 2-stage turbo fan
- C : Bell-mouth D : Panel

2. Air filter : standard equipment

3. Adaptation of transparent drainage parts

During installation, maintenance and operation, the drain pump and kit can be checked easily.

High ceiling mode

The compact cassette can be installed up to a height of 3.0 m (12/14/18/24).

Model code	The maximum height from floor to ceiling (m)	
	Standard mode	High ceiling mode
07	2.7	-
09	2.7	-
12	2.7	3.0
14	2.7	3.0
18	2.7	3.0
24	2.7	3.0

Compact design

World's first 24,000 Btu model in the compact cassette category (Easy installation by taking off ceiling panel of 600 x 600 size)



Model: AUXB09GATH / AUXB12GATH / AUXB14GATH
AUXB18GATH / AUXB24GATH



Specifications

Model name		AUXB09GATH	AUXB12GATH	AUXB14GATH	AUXB18GATH	AUXB24GATH
Power source		Single phase, 220-240V,				
Capacity	Cooling	2.8	3.6	4.5	5.6	7.1
	Heating	3.2	4.1	5.0	6.3	8.0
Input power		25	29	35	36	84
Airflow rate	High	550 (153)	600 (167)	680 (189)	710 (197)	1,030 (286)
	Med	450 (125)	530 (147)	590 (164)	580 (161)	830 (231)
	Low	350 (97)	390 (108)	390 (108)	400 (111)	450 (125)
Sound pressure level	High	35	37	38	41	50
	Med	30	34	34	35	44
	Low	25	27	27	27	30
Dimensions (H x W x D)		245 x 570 x 570	245 x 570 x 570	245 x 570 x 570	245 x 570 x 570	245 x 570 x 570
Weight		15 (33)	15 (33)	15 (33)	17 (37)	17 (37)
Connection pipe diameter	Liquid (Flare)	6.35	6.35	6.35	9.52	9.52
	Gas (Flare)	12.70	12.70	12.70	15.88	15.88
Drain hose diameter (I.D./O.D.)		25 / 32				
Cassette Grille		Model name: UTG-UFGC-W				
		Dimensions (H x W x D) mm: 50 x 700 x 700				
		Weight kg(lbs): 2.6 (6)				

Note : Specifications are based on the following conditions.

Cooling : Indoor temperature of 27°CDB / 19°CWB, and outdoor temperature of 35°CDB / 24°CWB.

Heating : Indoor temperature of 20°CDB / (15°CWB), and outdoor temperature of 7°CDB / 6°CWB.

Pipe length : 7.5 m; Height difference between outdoor unit and indoor unit : 0 m. Voltage : 230 [V].

Optional parts

- Air Outlet Shutter Plate: UTR-YDZB
- Insulation Kit for High Humidity: UTZ-KXGC

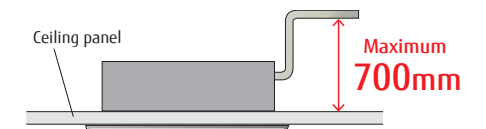

Dimensions (Unit: mm)

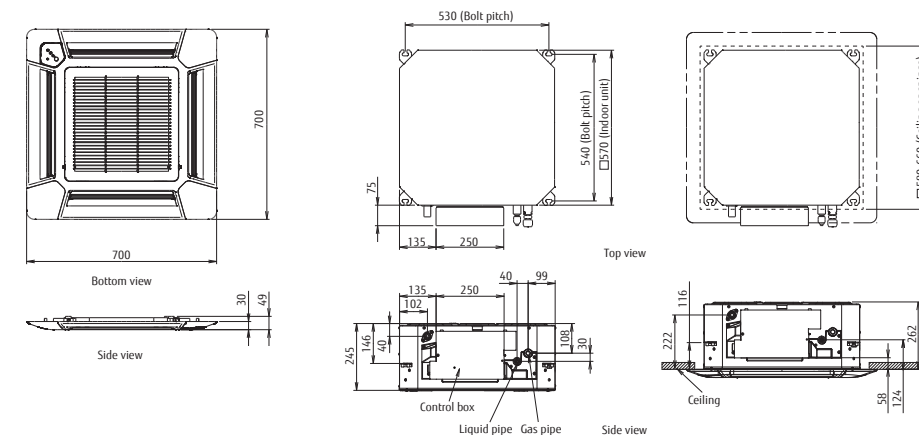

Cassette Slim/Large type Circular Flow



Unique Circular Flow design

New Cassette type realizes Circular Flow to blow large airflow in 360° direction by mounting high performance DC fan motor, new turbo fan and unique seamless airflow louver design.

- Ø7 mm high density heat exchanger
- New DC fan motor
- High efficient turbo fan
- Seamless airflow louver

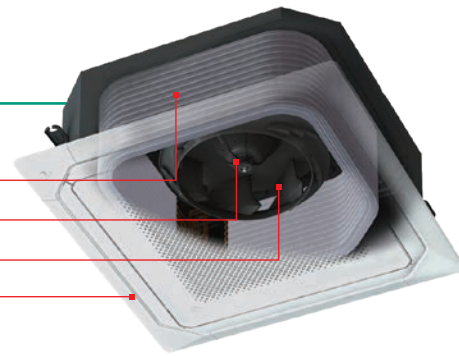

Uniform temperature air conditioning

Achieve a comfortable air conditioning spread to every corner of the room by circular flow & wide vertical airflow.

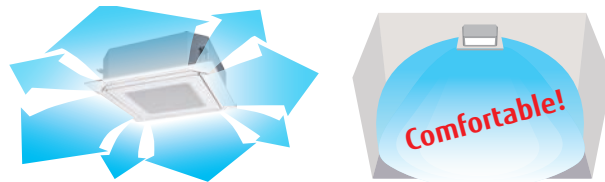

Individual louver control

Each louver can be set individually by Touch Panel Wired Remote Controller to enjoy the comfort of different directional airflows according to various room layouts.

* Touch Panel Wired RC (UTY-RNRGZ5) and Central Remote Controller(UTY-DCGGZ2) only



Comfortable air conditioning by preventing direct blowing of cold air and by providing swinging air flow simultaneously.

Efficient air conditioning based on the room layout

Occupancy sensor increases more energy saving

Energy saving operation starts automatically by detecting the motion of a person. 2 modes of save operation mode and stop mode can be selected.

* Touch Panel Wired RC (UTY-RNRGZ5) and Central Remote Controller(UTY-DCGGZ2) only



Human sensor (Optional)

2 modes can be selected

- Auto saving** Power is saved while people are away.
- Auto OFF** Operation stops after people go out.

Model: (Slim type)
AUXM018GTAH / AUXM024GTAH
(Large type)
AUXK018GTAH / AUXK024GTAH / AUXK030GTAH
AUXK034GTAH / AUXK036GTAH / AUXK045GTAH
AUXK054GTAH

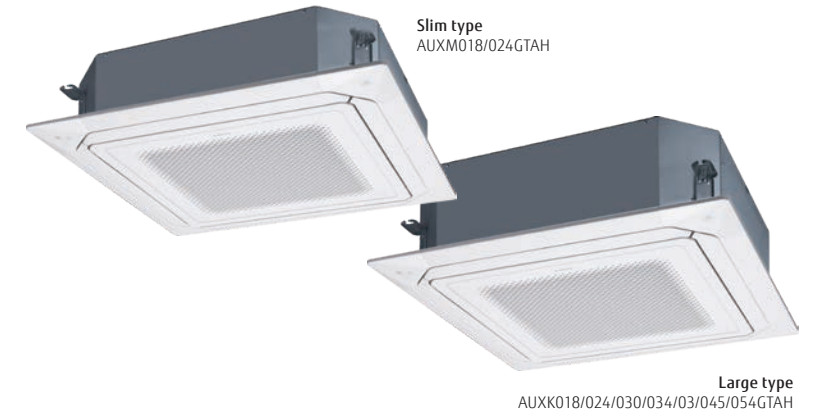

Specifications

Model name	AUXM018 GTAH	AUXM024 GTAH	AUXK018 GTAH	AUXK024 GTAH	AUXK030 GTAH	AUXK034 GTAH	AUXK036 GTAH	AUXK045 GTAH	AUXK054 GTAH	
Power source	Single phase, 220-240V, 60Hz									
Capacity	Cooling	5.6	7.1	5.6	7.1	9.0	10.0	11.2	12.5	14.0
	Heating	6.3	8.0	6.3	8.0	10.0	11.2	12.5	14.0	16.0
Input power	W	20	25	40	40	47	47	61	89	116
Airflow rate	High	1,050	1,120	1,420	1,420	1,440	1,440	1,620	1,820	2,040
	Med-High	930	1,050	1,360	1,360	1,440	1,440	1,500	1,590	1,800
	Med	900	930	1,300	1,300	1,340	1,340	1,400	1,500	1,590
	Med-Low	870	900	1,270	1,270	1,300	1,300	1,340	1,400	1,440
	Low	810	870	1,200	1,200	1,280	1,280	1,280	1,300	1,300
Sound pressure level	Quiet	780	780	1,150	1,150	1,150	1,150	1,150	1,150	1,150
	High	33	35	38	38	39	39	41	44	47
	Med-High	32	33	37	37	38	38	40	42	45
	Med	31	32	36	36	37	37	38	40	42
	Med-Low	30	31	35	35	36	36	37	38	39
Dimensions (H × W × D)	mm	246×840×840	246×840×840	288×840×840	288×840×840	288×840×840	288×840×840	288×840×840	288×840×840	288×840×840
	kg	24.0	24.5	26.5	26.5	29.5	29.5	29.5	29.5	29.5
Connection pipe diameter	Liquid (Flare)	6.35	9.52	6.35	9.52	9.52	9.52	9.52	9.52	9.52
	Gas (Flare)	12.70	15.88	12.70	15.88	15.88	15.88	15.88	15.88	15.88
Drain hose diameter (I.D./O.D.)		25 / 32								
Cassette Grille	Model name	UTG-UKGD-W/UTG-UKGA-B								
	Dimensions (H×W×D)	53×950×950								
Weight	kg	6.0								

Note : Specifications are based on the following conditions.

Cooling : Indoor temperature of 27°CDB / 19°CWB, and outdoor temperature of 35°CDB / 24°CWB.
Heating : Indoor temperature of 20°CDB / (15°CWB), and outdoor temperature of 7°CDB / 6°CWB.
Pipe length : 7.5 m; Height difference between outdoor unit and indoor unit : 0 m. Voltage : 230 [V].

When AUX*018GTAH is connected to the outdoor unit other than J-III, pipe diameter should be Ø9.52/Ø15.88 (Liq/Gas)
When AUXK036GTAH is connected to the outdoor unit other than J-III, gas pipe diameter should be Ø19.05.

Optional parts

- Human Sensor Kit: UTY-SHZXC
- Wide Panel: UTG-AKXA-W
- Panel Spacer: UTG-BKXA-W
- Cassette Grille: UTG-UKGD-W
- IR Receiver Unit: UTY-LBHXD
- Air Outlet Shutter Plate: UTR-YDZK
- Insulation Kit for High Humidity: UTZ-KXRA

Dimensions (Unit: mm)

Models: AUGM018 / AUGM024

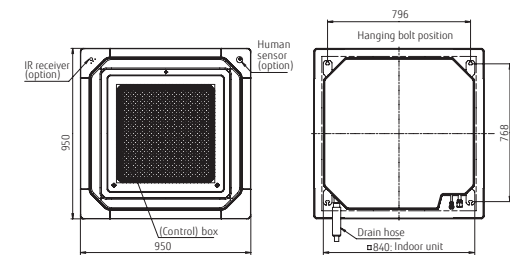

Models: AUGK018 / AUGK024 / AUGK030 / AUGK034
AUGK036 / AUGK045 / AUGK054

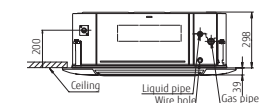
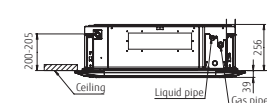
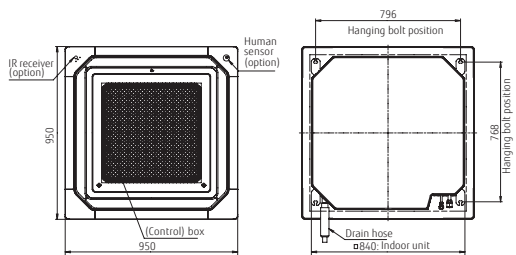

Slim Duct/ Slim Concealed Floor

(With drain pump)



Slim design

With a slim indoor design, this indoor can be installed in narrow ceiling spaces.

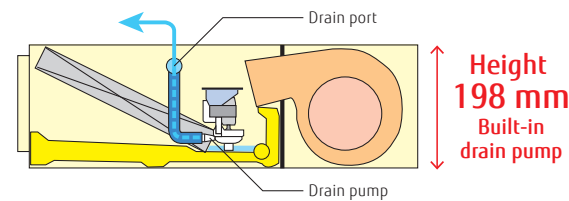

Air-intake

Air intake direction can be selected to match the installation site.

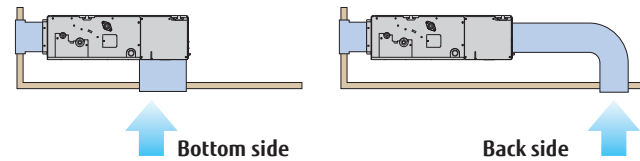

Flexible installation

Ceiling concealed

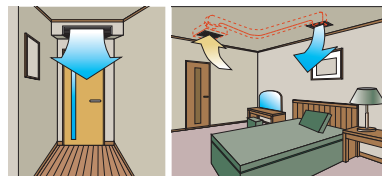

Floor concealed

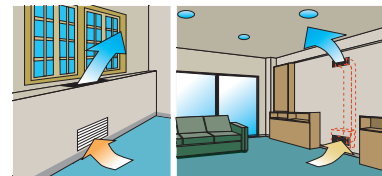

Selectable with a wide range of static pressure

By using DC fan motor, it is possible to change of static pressure range 0 to 90 Pa. The change of static pressure range is possible by remote controller.



Static pressure range
0 to 90 Pa

*24 model is 0 to 50 Pa

Filter (Accessory)

ARXD07 / 09 / 12 / 14 / 18

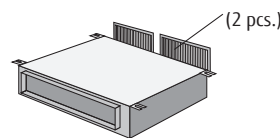

ARXD24

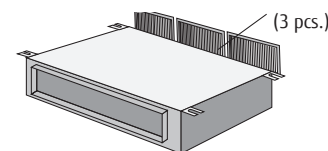

Model: ARXD07GATH / ARXD09GATH / ARXD12GATH
ARXD14GATH / ARXD18GATH / ARXD24GATH

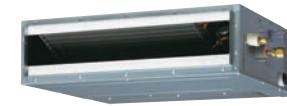

ARXD07/09/12/14GATH

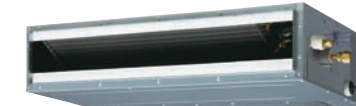

ARXD18GATH



ARXD24GATH

Slim
Concealed
Floor



Specifications

Model name		ARXD07GATH	ARXD09GATH	ARXD12GATH	ARXD14GATH	ARXD18GATH	ARXD24GATH
Power source		Single phase, 220-240V, 60Hz					
Capacity	Cooling	2.2	2.8	3.6	4.5	5.6	7.1
	Heating	2.8	3.2	4.0	5.0	6.3	8.0
Input power		44	50	54	92	83	122
Airflow rate	High	550 (153)	600 (167)	600 (167)	800 (222)	940 (261)	1,330 (369)
	Med	490 (136)	550 (153)	510 (142)	710 (197)	840 (233)	1,240 (344)
	Low	440 (122)	480 (133)	450 (125)	610 (169)	750 (208)	1,100 (306)
Static pressure range		0 to 90	0 to 90	0 to 90	0 to 90	0 to 90	0 to 50
Standard static pressure		25	25	25	25	25	25
Sound pressure level	High	28	29	30	34	34	35
	Med	25	26	27	32	32	32
	Low	22	24	24	28	28	29
Dimensions (H × W × D)		198 × 700 × 620	198 × 700 × 620	198 × 700 × 620	198 × 700 × 620	198 × 900 × 620	198 × 1,100 × 620
Weight		17 (37)	17 (37)	18 (40)	18 (40)	22 (48)	26 (57)
Connection pipe diameter	Liquid (Flare)	6.35	6.35	6.35	6.35	9.52	9.52
	Gas (Flare)	12.70	12.70	12.70	12.70	15.88	15.88
Drain hose diameter (I.D./O.D.)		25 / 32					

Note : Specifications are based on the following conditions.

Cooling : Indoor temperature of 27°CDB / 19°CWB, and outdoor temperature of 35°CDB / 24°CWB.

Heating : Indoor temperature of 20°CDB / (15°CWB), and outdoor temperature of 7°CDB / 6°CWB.

Pipe length : 7.5 m; Height difference between outdoor unit and indoor unit : 0 m. Voltage : 230 [V].

Optional parts

Auto louvre grille kit : UTD-GXTA-W (for ARXD07 - 14)
UTD-GXTB-W (for ARXD18)
UTD-GXTC-W (for ARXD24)

Remote Sensor Unit : UTY-XSZX

IR Receiver Unit : UTB-YWC

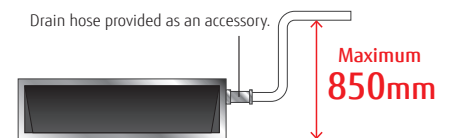

Dimensions (Unit: mm)

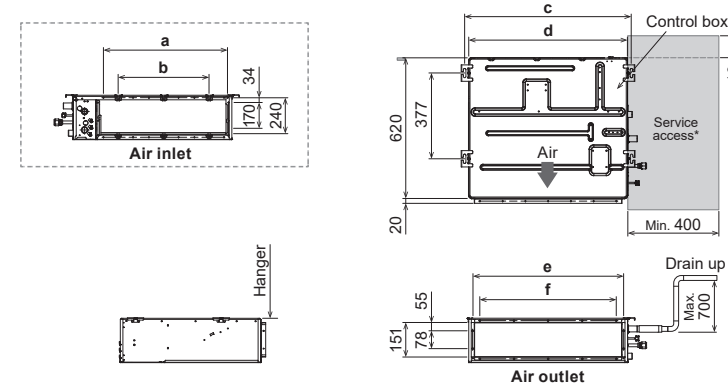

	ARXD07-14 GATH	ARXD18 GATH	ARXD24 GATH
a	574	774	974
b	P200×2=400	P200×3=600	P200×4=800
c	734	934	1,134
d	700	900	1,100
e	650	850	1,050
f	P100×6=600	P100×8=800	P100×10=1,000

*The design of the service access depends on the installation method. Refer to the installation manual for more information.

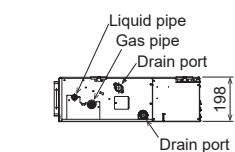

Medium Static Pressure Duct



Slim & Compact design

The slim and compact design of the indoor unit, with the control box mounted on the side of the unit, allows installation in narrow spaces.

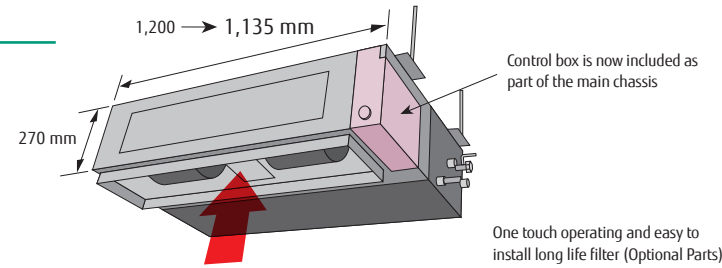

Easy maintenance

See below for the case of rear suction type

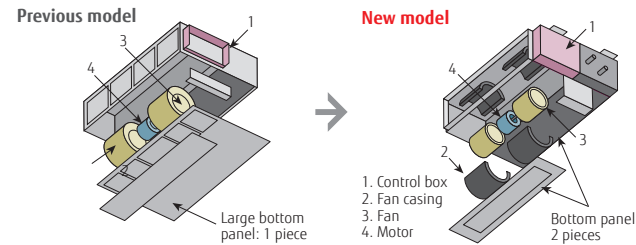

Structural improvement is attained by making the bottom panel two pieces, front and rear. The internal fan casing is also manufactured in two pieces, namely upper and lower. The maintenance of the motor and fan can be easily carried out by removing the rear panel and the lower part of the casing while leaving the main chassis installed.

Installation styles

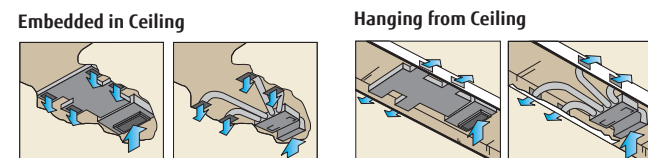

Two-direction drain piping

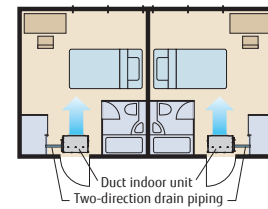

Easy setting by using remote controller

The change of static pressure range is possible by remote controller

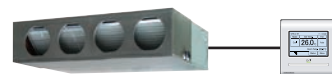

Selectable with a wide range of static pressure

It is possible to change of static pressure range 0 to 150 Pa.

Static pressure range
0 to 150 Pa

Model: ARXA24GBTH / ARXA30GBTH
ARXA36GBTH / ARXA45GBTH



Specifications

Model name		ARXA24GBTH	ARXA30GBTH	ARXA36GBTH	ARXA45GBTH
Power source		Single phase, 220-240V, 60Hz			
Capacity	Cooling	7.1	9.0	11.2	12.5
	Heating	8.0	10.0	12.5	14.0
Input power		94	108	194	240
Airflow rate	High	1,280 (356)	1,410 (392)	1,840 (511)	1,970 (547)
	Med	990 (275)	1,280 (356)	1,600 (444)	1,860 (517)
	Low	840 (233)	1,150 (319)	1,470 (408)	1,640 (456)
Static pressure range		30 to 150	30 to 150	30 to 150	30 to 150
Standard static pressure		100	100	100	100
Sound pressure level	High	31	34	37	41
	Med	27	32	35	38
	Low	23	29	33	36
Dimensions (H x W x D)		270 x 1,135 x 700	270 x 1,135 x 700	270 x 1,135 x 700	270 x 1,135 x 700
Weight		39 (86)	42 (93)	42 (93)	42 (93)
Connection pipe diameter	Liquid (Flare)	9.52	9.52	9.52	9.52
	Gas (Flare)	15.88	15.88	19.05	19.05
Drain hose diameter (I.D./O.D.)		25 / 32			

Note : Specifications are based on the following conditions.
Cooling : Indoor temperature of 27°CDB / 19°CWB, and outdoor temperature of 35°CDB / 24°CWB.
Heating : Indoor temperature of 20°CDB / (15°CWB), and outdoor temperature of 7°CDB / 6°CWB.
Pipe length : 7.5 m; Height difference between outdoor unit and indoor unit : 0 m. Voltage : 230 [V].

Optional parts

- Remote Sensor Unit : UTY-XSZX
- Long Life Filter : UTD-LF25NA
- Flange (Round) : UTD-RF204
- IR Receiver Unit : UTB-YWC
- Flange (Square) : UTD-SF045T
- Drain Pump Unit : UTZ-PX1NBA

Dimensions (Unit: mm)

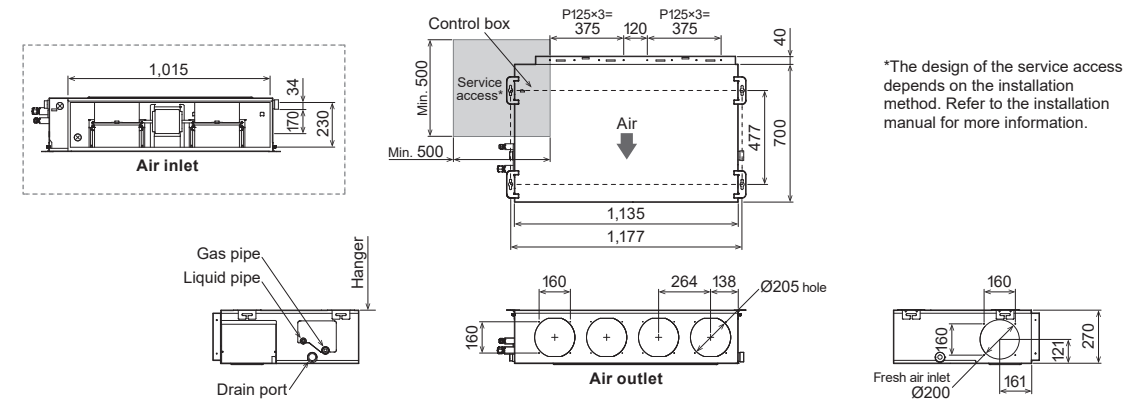

*The design of the service access depends on the installation method. Refer to the installation manual for more information.

High Static Pressure Duct



Static pressure selection

By using DC fan motor, it is possible to change static pressure range from 0 to 200 Pa (ARXC36) / 300 Pa (ARXC72 / 90 / 96).



Easy installation (Compact size & Lightweight)

A compact size and lightweight indoor unit has been developed by reducing the basic chassis and the overall material weight.

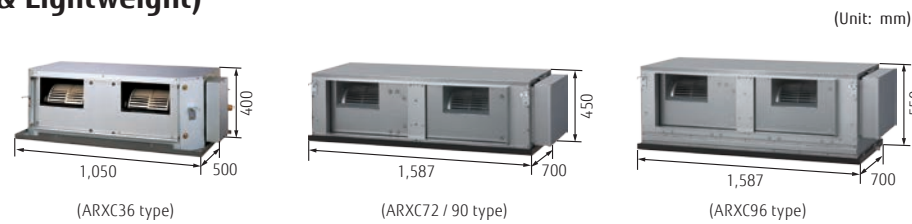

Low noise

Models : ARXC36

Cutting off the corners of the conventional indoor unit front panel and fan casing, has enabled less turbulent air flow. Low noise is realized by adopting a plastic case and a plastic fan.

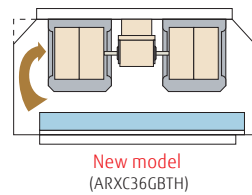

ARXC36GBTH : Plastic fan [42dB(A)]

* Model : Material (At 100 Pa : Actual noise measurement value)

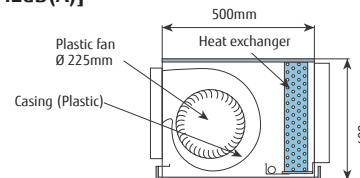

Low energy consumption by high efficiency DC fan motor

Improved motor efficiency from previous model.

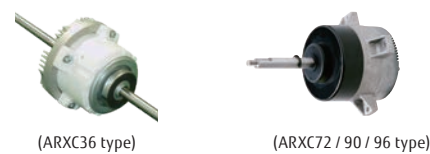

Model: ARXC36GBTH
ARXC72GBTH / ARXC90GBTH
ARXC96GATH



Specifications

Model name		ARXC36GBTH	ARXC72GBTH	ARXC90GBTH	ARXC96GATH
Power source		Single phase, 220-240V, 60Hz			
Capacity	Cooling	11.2	22.4	25.0	28.0
	Heating	12.5	25.0	28.0	31.5
Input power		207	681	819	838
Airflow rate	High	1,990 (553)	3,900 (1,083)	4,300 (1,195)	4,850 (1,347)
	Med	1,680 (467)	3,300 (917)	4,000 (1,111)	4,250 (1,181)
	Low	1,330 (369)	3,000 (833)	3,500 (972)	3,600 (1,000)
Static pressure range		0 to 200	0 to 300	0 to 300	0 to 300
Standard static pressure		100	150	150	150
Sound pressure level	High	42	47	48	48
	Med	36	43	46	45
	Low	32	40	44	42
Dimensions (H x W x D)		400 x 1,050 x 500	450 x 1,587 x 700	450 x 1,587 x 700	550 x 1,587 x 700
Weight		40 (88)	84 (185)	84 (185)	105 (231)
Connection pipe diameter	Liquid	9.52 (Flare)	12.70 (Brazing)	12.70 (Brazing)	12.70 (Brazing)
	Gas	19.05 (Flare)	22.22 (Brazing)	22.22 (Brazing)	22.22 (Brazing)
Drain hose diameter (I.D./O.D.)		25 / 32			

Note : Specifications are based on the following conditions.

Cooling : Indoor temperature of 27°CDB / 19°CWB, and outdoor temperature of 35°CDB / 24°CWB.

Heating : Indoor temperature of 20°CDB / (15°CWB), and outdoor temperature of 7°CDB / 6°CWB.

Pipe length : 7.5 m; Height difference between outdoor unit and indoor unit : 0 m. Voltage : 230 [V].

Optional parts

Long-Life Filter : UTD-LF60KA (For ARXC36)

Remote Sensor Unit : UTU-XSZX

IR Receiver Unit : UTB-YWC

Dimensions (Unit: mm)

Models: ARXC36

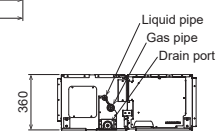
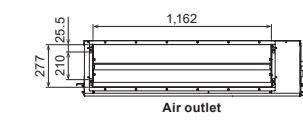
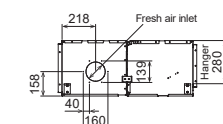
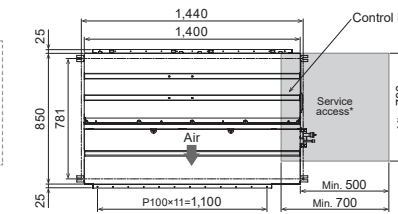
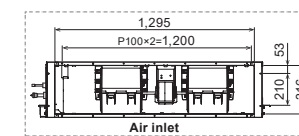

Models: ARXC72 / ARXC90 / ARXC96

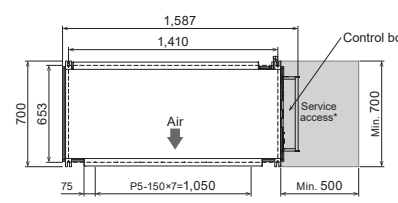
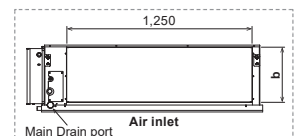

	ARXC72/90GBTH	ARXC96GATH
a	450	550
b	370	470

*The design of the service access depends on the installation method. Refer to the installation manual for more information.

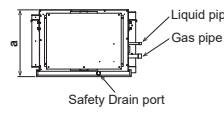
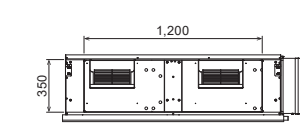
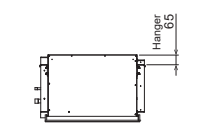

High Static Pressure Duct



Easy installation (Compact size & Lightweight)

A compact size and lightweight indoor unit has been developed by reducing the basic chassis and the overall material weight.

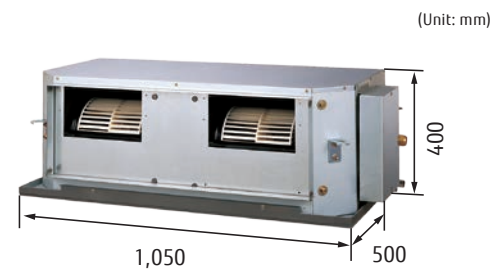

Static pressure selection

Models : ARKC45 / ARKC60

2 Types of static pressure mode are selectable.



Low noise

Models : ARKC45 / ARKC60

Cutting off the corners of the conventional indoor unit front panel and fan casing, has enabled less turbulent air flow. Low noise is realized by adopting a plastic case and a plastic fan.

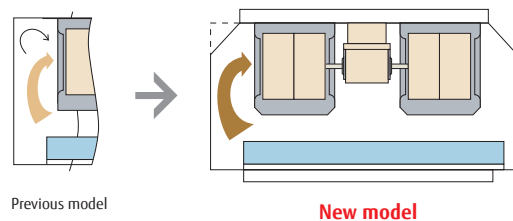

Installation styles

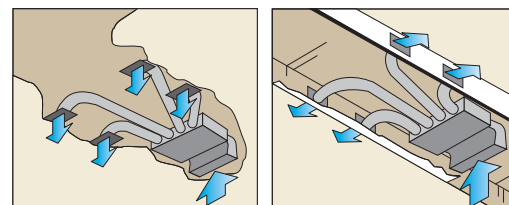

Model: ARXC45GATH / ARXC60GATH



Specifications

Model name		ARKC45GATH	ARKC60GATH
Power source		Single phase, 220-240V, 60Hz	
Capacity	Cooling	12.5	18.0
	Heating	14.0	20.0
Input power		715	730
Airflow rate	High	3,500 (972)	3,500 (972)
	Med	3,000 (833)	3,000 (833)
	Low	2,460 (683)	2,460 (683)
Static pressure range		100 to 250	100 to 250
Standard static pressure		100	100
Sound pressure level	High	49	49
	Med	45	45
	Low	42	42
Dimensions (H x W x D)		400 x 1,050 x 500	400 x 1,050 x 500
Weight		46 (101)	46 (101)
Connection pipe diameter	Liquid (Flare)	9.52 (Flare)	9.52 (Flare)
	Gas (Flare)	19.05 (Flare)	19.05 (Flare)
Drain hose diameter (I.D./O.D.)		25 / 32	

Note : Specifications are based on the following conditions.

Cooling : Indoor temperature of 27°CDB / 19°CWB, and outdoor temperature of 35°CDB / 24°CWB.

Heating : Indoor temperature of 20°CDB / (15°CWB), and outdoor temperature of 7°CDB / 6°CWB.

Pipe length : 7.5 m; Height difference between outdoor unit and indoor unit : 0 m. Voltage : 230 [V].

Optional parts

Long-Life Filter : UTD-LF60KA

IR Receiver Unit : UTB-YWC

Remote Sensor Unit : UTY-XSZX

Dimensions (Unit: mm)

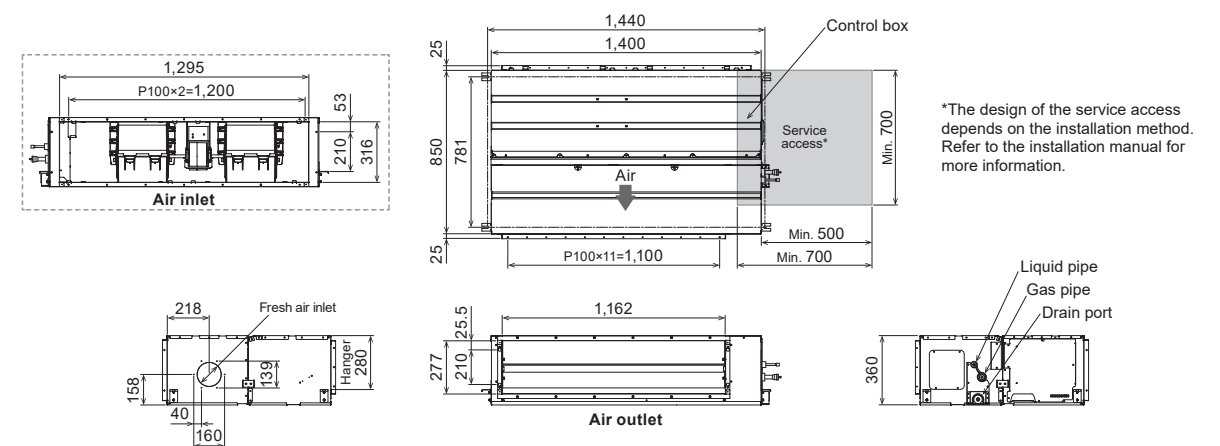

*The design of the service access depends on the installation method. Refer to the installation manual for more information.

Large Airflow Duct



Large airflow volume

It can be installed in places such as early replacement of air required by large airflow volume.

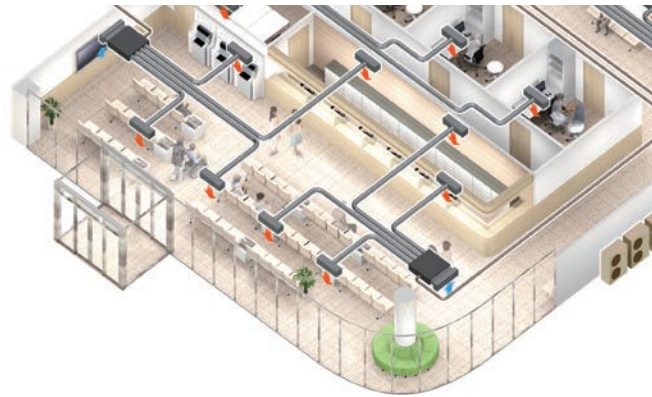
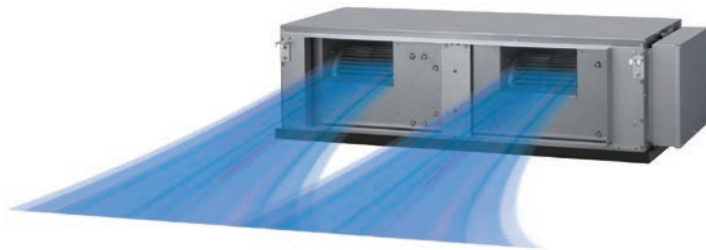

Selectable with a wide range of static pressure

Static pressure range
50 to 250 Pa
(30 / 34class)

Static pressure range
50 to 300 Pa
(36 / 45class)



Installation styles

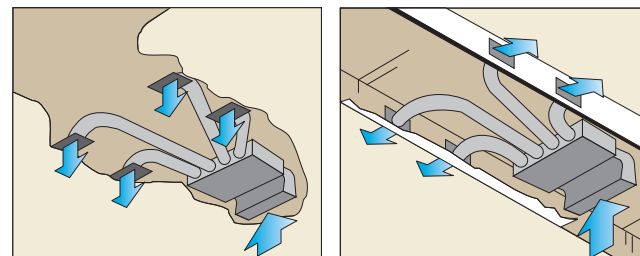

Model: ARXN18GATH / ARXN24GATH / ARXN30GATH
ARXN34GATH / ARXN36GATH / ARXN45GATH



Specifications

Model name	ARXN18GATH	ARXN24GATH	ARXN30GATH	ARXN34GATH	ARXN36GATH	ARXN45GATH	
Power source	Single phase, 220-240V, 50Hz						
Capacity	Cooling	5.6	7.1	9.0	10.0	11.2	12.5
	Heating	6.3	8.0	10.0	11.2	12.5	14.0
Input power	W	154	205	306	432	572	572
Airflow rate	High	2,280 (633)	2,640 (733)	3,200 (889)	3,720 (1,033)	4,120 (1,145)	4,120 (1,145)
	Med	-	-	-	-	-	-
	Low	-	-	-	-	-	-
Static pressure range	Pa	50 to 100	50 to 150	50 to 250	50 to 250	50 to 300	50 to 300
Standard static pressure	Pa	50	50	50	50	60	60
Sound pressure level	High	35	37	40	43	45	45
	Med	-	-	-	-	-	-
	Low	-	-	-	-	-	-
Dimensions (H x W x D)	mm	450 x 1,587 x 700	450 x 1,587 x 700	450 x 1,587 x 700	450 x 1,587 x 700	450 x 1,587 x 700	450 x 1,587 x 700
Weight	kg(lbs)	84 (185)	84 (185)	84 (185)	84 (185)	84 (185)	84 (185)
Connection pipe diameter	Liquid (Flare)	9.52	9.52	9.52	9.52	9.52	9.52
	Gas (Flare)	15.88	15.88	15.88	15.88	19.05	19.05
Drain hose diameter (I.D./O.D.)		25 / 32					

Note : Specifications are based on the following conditions.

Cooling : Indoor temperature of 27°CDB / 19°CWB, and outdoor temperature of 35°CDB / 24°CWB.
Heating : Indoor temperature of 20°CDB / (15°CWB), and outdoor temperature of 7°CDB / 6°CWB.
Pipe length : 7.5 m; Height difference between outdoor unit and indoor unit : 0 m. Voltage : 230 [V].

Large Airflow Duct can be connected to V-III Series only.

Optional parts

Remote Sensor Unit : UTY-XSZX

Dimensions (Unit: mm)

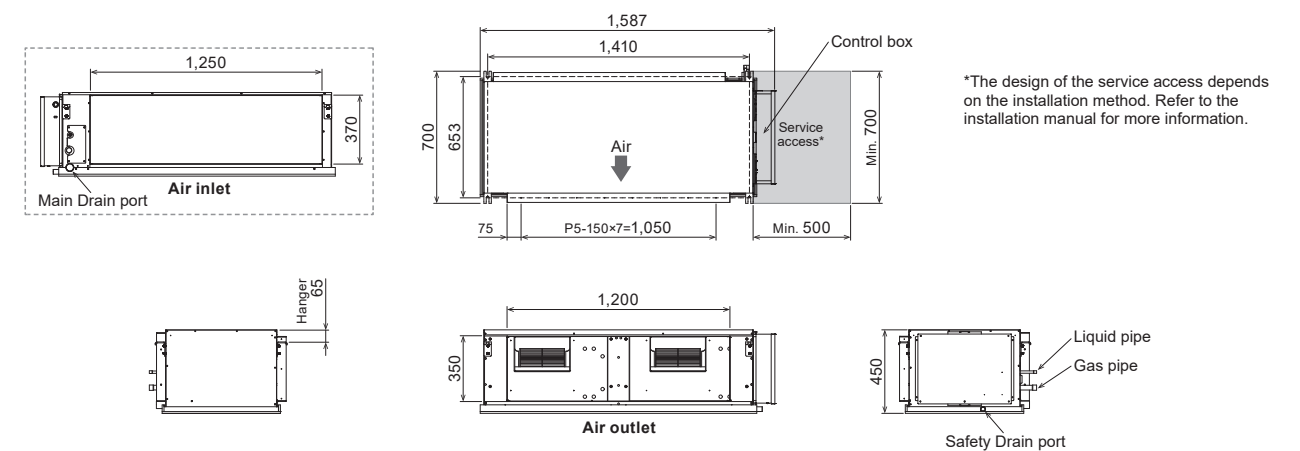

Floor/Ceiling



Flexible installation

Example for floor installation

Floor console



Example for ceiling installation

Under ceiling



Double auto swing

A combination of up/down and right/left directional swing allows three-dimensional air direction control.

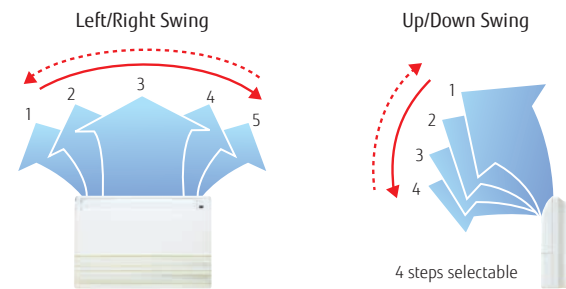

High power DC fan motor

- High power
- Wide rotation range
- High efficiency



Compact design

Symmetrical, slim and compact design.

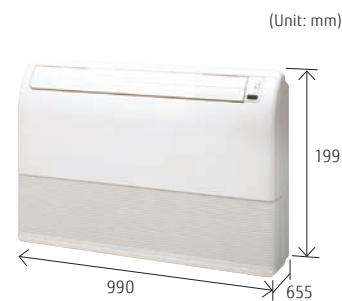

Model: ABHA12GATH / ABHA14GATH
ABHA18GATH / ABHA24GATH



Specifications

Model name		ABHA12GATH	ABHA14GATH	ABHA18GATH	ABHA24GATH
Power source		Single phase, 220-240V, 60Hz			
Capacity	Cooling	3.6	4.5	5.6	7.1
	Heating	4.0	5.0	6.3	8.0
Input power		30	42	74	99
Airflow rate	High	660 (183)	780 (216)	1,000 (277)	1,000 (277)
	Med	570 (158)	640 (177)	720 (199)	820 (227)
	Low	490 (136)	550 (152)	580 (161)	680 (188)
Sound pressure level	High	36	40	46	47
	Med	32	36	39	42
	Low	28	34	35	37
Dimensions (H × W × D)		199 × 990 × 655	199 × 990 × 655	199 × 990 × 655	199 × 990 × 655
Weight		25 (55)	26 (57)	26 (57)	27 (59)
Connection pipe diameter	Liquid (Flare)	6.35	6.35	9.52	9.52
	Gas (Flare)	12.70	12.70	15.88	15.88
Drain hose diameter (I.D./O.D.)		25 / 32			

Note : Specifications are based on the following conditions.

Cooling : Indoor temperature of 27°CDB / 19°CWB, and outdoor temperature of 35°CDB / 24°CWB.

Heating : Indoor temperature of 20°CDB / (15°CWB), and outdoor temperature of 7°CDB / 6°CWB.

Pipe length : 7.5 m; Height difference between outdoor unit and indoor unit : 0 m. Voltage : 230 [V].

Optional parts

Dimensions (Unit: mm)

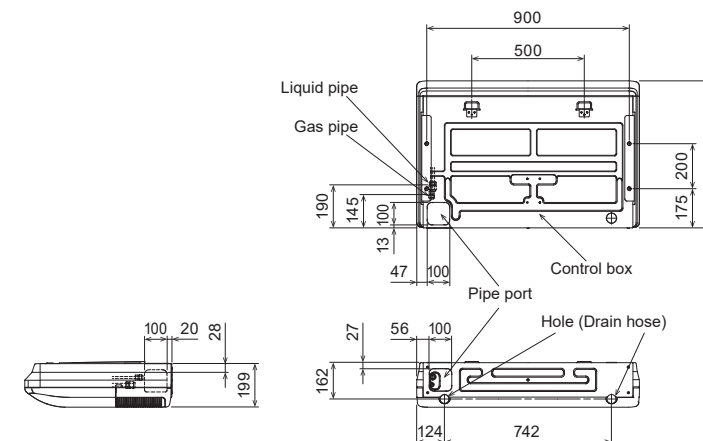

Ceiling



Installation

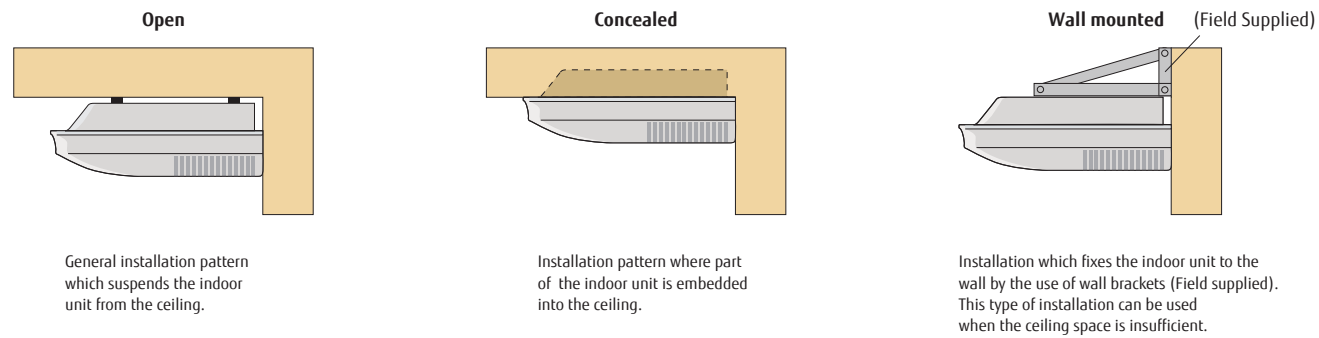

Double auto swing and wide airflow

Auto airflow direction and auto swing

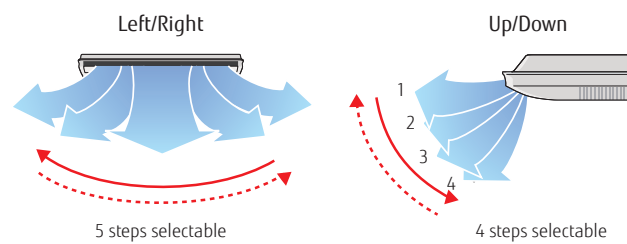

High power DC fan motor

- High power
- Wide rotation range
- High efficiency



Long airflow

Long Airflow ensures comfort to every corner of a large room.

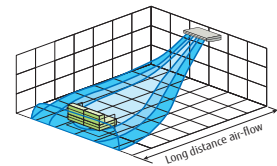

Fresh air intake

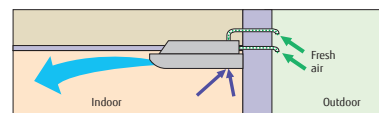

Slim & Compact design

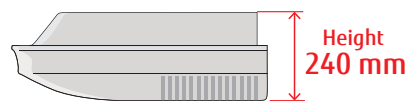

Model: ABHA30GATH / ABHA36GATH
ABHA45GATH / ABHA54GATH



Specifications

Model name		ABHA30GATH	ABHA36GATH	ABHA45GATH	ABHA54GATH
Power source		Single phase, 220-240V, 60Hz			
Capacity	Cooling	9.0	11.2	12.5	14.0
	Heating	10.0	12.5	14.0	16.0
Input power		66	85	131	180
Airflow rate	High	1,630 (452)	1,690 (469)	2,010 (558)	2,270 (629)
	Med	1,370 (379)	1,400 (389)	1,600 (444)	1,780 (493)
	Low	1,140 (316)	1,170 (325)	1,230 (342)	1,280 (355)
Sound pressure level	High	42	45	48	51
	Med	38	38	42	45
	Low	33	34	35	36
Dimensions (H × W × D)		240 × 1,660 × 700	240 × 1,660 × 700	240 × 1,660 × 700	240 × 1,660 × 700
Weight		46 (101)	48 (106)	48 (106)	48 (106)
Connection pipe diameter	Liquid (Flare)	9.52	9.52	9.52	9.52
	Gas (Flare)	15.88	19.05	19.05	19.05
Drain hose diameter (I.D./O.D.)		25 / 32			

Note : Specifications are based on the following conditions.

Cooling : Indoor temperature of 27°CDB / 19°CWB, and outdoor temperature of 35°CDB / 24°CWB.

Heating : Indoor temperature of 20°CDB / (15°CWB), and outdoor temperature of 7°CDB / 6°CWB.

Pipe length : 7.5 m; Height difference between outdoor unit and indoor unit : 0 m. Voltage : 230 [V].

Optional parts

Drain Pump Unit : UTR-DPB24T
Flange : UTD-RF204

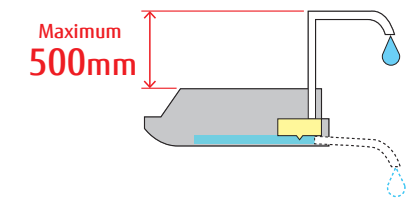

Dimensions (Unit: mm)

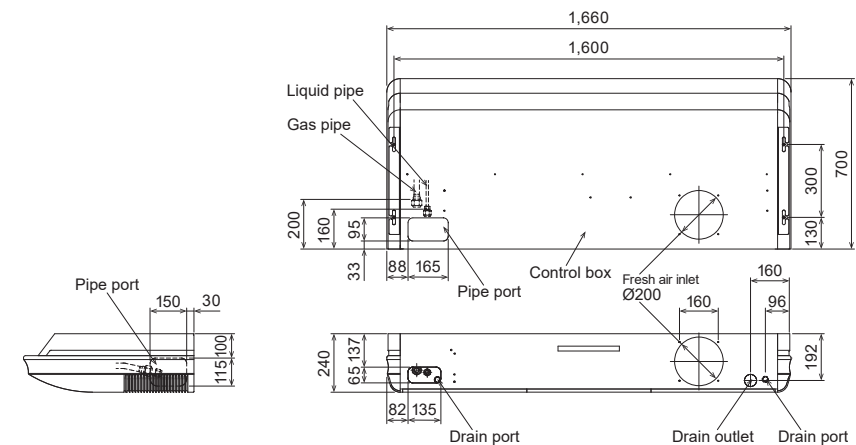

Wall-mounted type



Filter features

High performance filter provides high quality air conditioning



Long-life* Ion Deodorization Filter

The filter deodorizes by powerfully decomposing absorbed odors using the oxidizing and reducing effects of ions generated by the ultra-fine-particle ceramic.

(*The filter can be used for approx. 3 years if it is washed under water to restore its surface action when it is dirty.)



Apple-catechin Filter

Fine dust, invisible mold spores, and harmful microorganisms are absorbed onto the filter by static electricity, and further growth is inhibited and deactivated by the polyphenol extracted from apples.

Deodorizing effect (Odor reduction rate)

Ammonia

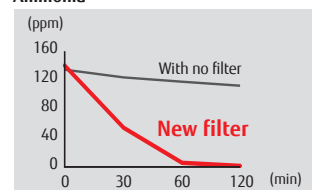

Trimethylamine

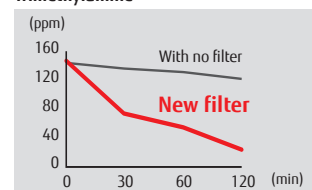

Hydrogen sulfate



High performance filters have been thoroughly tested by the Environmental Sanitary Inspection Center using an advanced Deodorization Test.

Compact size

Powerful output even compact design

Though the indoor unit is compact, it features a large, high pressure cross fan (90 mm diameter) in a centre mounted configuration and a Lambda type heat exchanger to provide plenty of power.

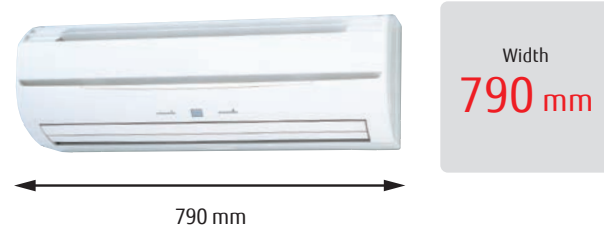

High power DC fan motor

- High power
- Wide rotation range
- High efficiency
- Compact size



Easy maintenance

Easy maintenance has been realized as the front panel can be removed for easy access.

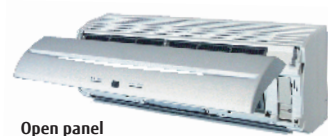

Model: (EEV internal)
ASHA07GATH / ASHA09GATH
ASHA12GATH / ASHA14GATH



Specifications

Model name		ASHA07GATH	ASHA09GATH	ASHA12GATH	ASHA14GATH
Power source		Single phase, 220-240V, 60Hz			
Capacity	Cooling	2.2	2.8	3.6	4.5
	Heating	2.8	3.2	4.1	5.0
Input power		17	18	22	34
Airflow rate	High	490 (136)	500 (139)	560 (156)	670 (186)
	Med	450 (125)	450 (125)	480 (133)	490 (136)
	Low	370/420*1 (103/117*1)	370/420*1 (103/117*1)	420 (117)	420 (117)
Sound pressure level	High	35	36	39	44
	Med	33	33	35	37
	Low	27 / 31*1	27 / 31*1	31	32
Dimensions (H × W × D)		275 × 790 × 215	275 × 790 × 215	275 × 790 × 215	275 × 790 × 215
Weight		9 (20)	9 (20)	9 (20)	9 (20)
Connection pipe diameter	Liquid (Flare)	6.35	6.35	6.35	6.35
	Gas (Flare)	12.70	12.70	12.70	12.70
Drain hose diameter (I.D./O.D.)		13.8 / 15.8 to 16.7			

Note : Specifications are based on the following conditions.

Cooling : Indoor temperature of 27°CDB / 19°CWB, and outdoor temperature of 35°CDB / 24°CWB.

Heating : Indoor temperature of 20°CDB / (15°CWB), and outdoor temperature of 7°CDB / 6°CWB.

Pipe length : 7.5 m; Height difference between outdoor unit and indoor unit : 0 m. Voltage : 230 [V].

*1 : This value is under cooling operation.

Optional parts

Dimensions (Unit: mm)

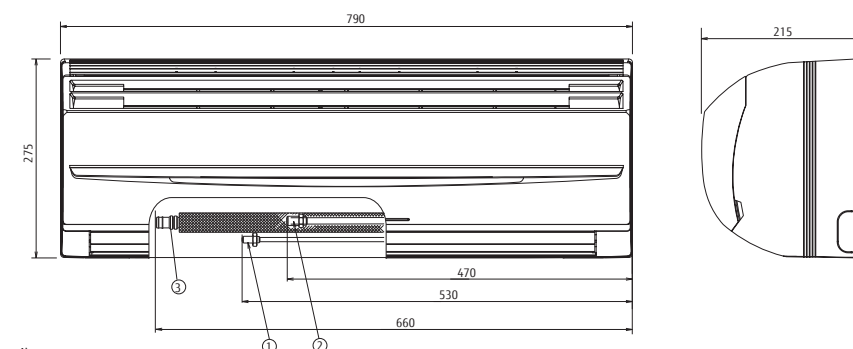

- ① Refrigerant piping flare connection (Liquid)
- ② Refrigerant piping flare connection (Gas)
- ③ Drain piping connection

Wall-mounted type



More comfort airflow by adopting power diffuser

"Vertical airflow" provides powerful floor level heating

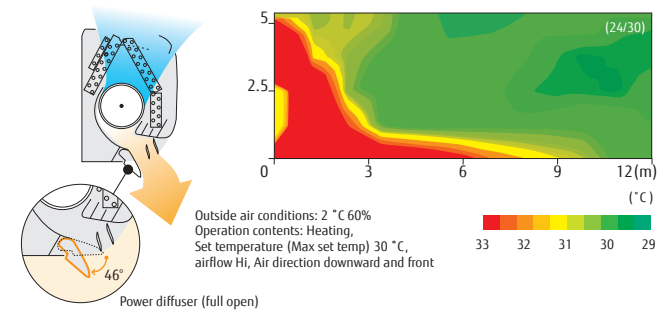

"Horizontal airflow" does not blow cool air directly at the occupants in the room

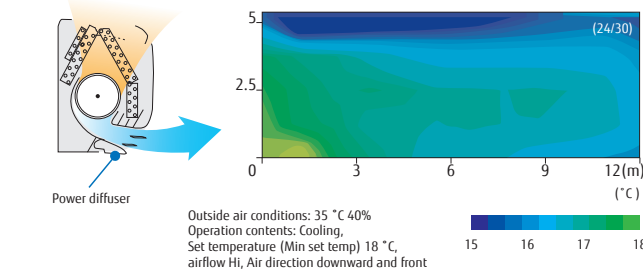

Air conditioner filter features

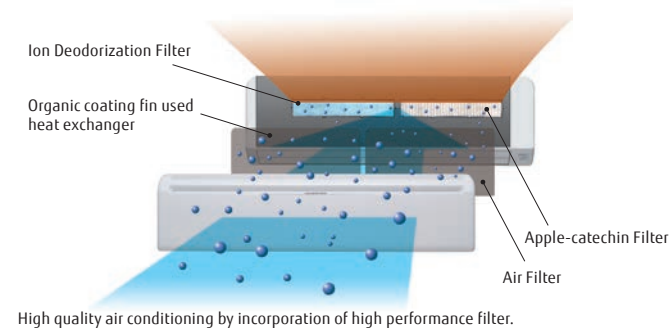

Ion Deodorization Filter
The filter deodorizes by powerfully decomposing absorbed odors using the oxidizing and reducing effects of ions generated by the ultra-fine-particle ceramic.

Apple-catechin Filter
Apple-catechin filter uses static electricity to clean fine particles and dust in the air.

Double auto swing

A combination of up/down and right/left directional swing allows three-dimensional air direction control.

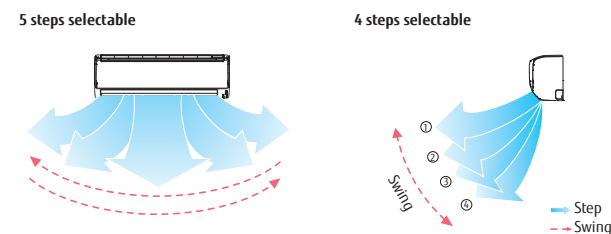

Model: ASHA18GATH / ASHA24GATH / ASHA30GATH



Specifications

Model name		ASHA18GATH	ASHA24GATH	ASHA30GATH
Power source		Single phase, 220-240V, 60Hz		
Capacity	Cooling	5.6	7.1	8.0
	Heating	6.3	8.0	9.0
Input power		32	60	91
Airflow rate	High	840 (233)	1,100 (305)	1,240 (343)
	Med	770 (213)	910 (252)	980 (271)
	Low	690 (191)	730 (202)	770 (213)
Sound pressure level	High	41	48	52
	Med	39	43	45
	Low	35	35	35
Dimensions (H × W × D)		320 × 998 × 228	320 × 998 × 228	320 × 998 × 228
Weight		15 (33)	15 (33)	15 (33)
Connection pipe diameter	Liquid (Flare)	9.52	9.52	9.52
	Gas (Flare)	15.88	15.88	15.88
Drain hose diameter (I.D./O.D.)		12 / 16		

Note : Specifications are based on the following conditions.
Cooling : Indoor temperature of 27 °CDB / 19 °CWB, and outdoor temperature of 35 °CDB / 24 °CWB.
Heating : Indoor temperature of 20 °CDB / (15 °CWB), and outdoor temperature of 7 °CDB / 6 °CWB.
Pipe length : 7.5 m; Height difference between outdoor unit and indoor unit : 0 m. Voltage : 230 [V].

Optional parts

Dimensions (Unit: mm)

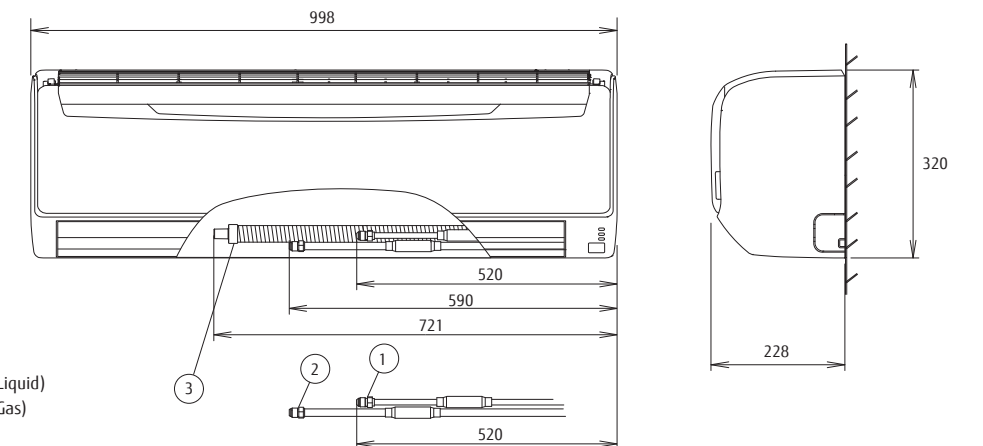

- ① Refrigerant piping flare connection (Liquid)
- ② Refrigerant piping flare connection (Gas)
- ③ Drain piping connection

VRF CONTROL SYSTEMS

BEST CONTROL SOLUTION FOR EACH PROPERTY

CONTROL SYSTEM OVERVIEW

COMPARISON TABLE OF CONTROLLERS

Individual Controller

Centralized Controller

Converter / Adaptor











User friendly control system provides individual control to centralized control

The VRF control system can perform air conditioning control of individual room, centralized control by floor or by building, or centralized energy saving air conditioning control for large buildings. A variety of air conditioning management schemes are available to match the application, such as linking with the building control system, linking with a single split models, and using various interfaces.











BEST CONTROL SOLUTION FOR EACH PROPERTY

Fujitsu General provides the best control solutions suitable for the various properties.











SHOP

Type	Individual Control			Centralized Control		Integrating Control (Interface)		
								
	Wired Remote Controller	Central Remote Controller	System Controller	Network Converter for LonWorks®	MODBUS® Converter	KNX® Convertor		
	UTY-RNRGZ5, UTY-RLRG, UTY-RCRGZ1, UTY-RCRGZ1K	UTY-DCGGZ3	UTY-APGXZ1, UTY-ALGXZ1	UTY-VLGX	UTY-VMGX	UTY-VKGX		
Automatic control of A/C (Schedule timer, Weekly timer etc.)	●	●	●					
Limited control for staff (RC Prohibition, Room temp set point limitation etc.)		●	●	●				
Group Control		●	●					
Advanced Energy Saving (Peak cut, Indoor unit lead lag operation etc.)			●					
Remote Management			●					
Manage multiple sites			●					
Monitor energy consumption			●					
Control third party products			●					
Integrate FGL A/C into BMS				●	●	●		

HOTEL

Type	Individual Control			Centralized Control		Integrating Control (Interface)				
										
	Wired Remote Controller	Simple Remote Controller	Wireless Remote Controller	Central Remote Controller	System Controller	BACnet® Gateway	Network Converter for LonWorks®	MODBUS® Converter	KNX® Convertor	External Switch Controller
	UTY-RNRGZ5, UTY-RLRG, UTY-RCRGZ1, UTY-RCRGZ1K	UTY-RSRG, UTY-RHRG	UTY-LNHG	UTY-DCGGZ3	UTY-APGXZ1, UTY-ALGXZ1	UTY-ABGXZ1, UTY-VBGX	UTY-VLGX	UTY-VMGX	UTY-VKGX	UTY-TERX
Local control for hotel guest	●	●	●							
Centralized A/C control for common space				●	●	●	●	●	●	
Limited control for hotel guests				●	●	●	●	●	●	
Remote Management					●					
Advanced Energy Saving (Peak cut, Indoor unit lead lag operation etc.)					●	●				
Monitor energy consumption					●					
Control third party products					●					
Integrate FGL A/C into BMS						●	●	●	●	
Interlock with window contact										●
Interlock with key-card										●

OFFICE

Type	Individual Control			Centralized Control		Integrating Control (Interface)				
										
	Wired Remote Controller	Simple Remote Controller	Wireless Remote Controller	Central Remote Controller	System Controller	BACnet® Gateway	Network Converter for LonWorks®	MODBUS® Converter	KNX® Convertor	External Switch Controller
	UTY-RNRGZ5, UTY-RLRG, UTY-RCRGZ1, UTY-RCRGZ1K	UTY-RSRG, UTY-RHRG	UTY-LNHG	UTY-DCGGZ3	UTY-APGXZ1, UTY-ALGXZ1	UTY-ABGXZ1, UTY-VBGX	UTY-VLGX	UTY-VMGX	UTY-VKGX	UTY-TERX
Local control for office staff	●	●	●	●						
Automatic control of A/C (Schedule timer, Weekly timer etc.)	●		●	●	●	●				
Centralized A/C control for management				●	●	●	●	●	●	
Limited control for office staff (RC Prohibition, Room temp set point limitation etc.)				●	●	●	●	●	●	
Advanced Energy Saving (Peak cut, Indoor unit lead lag operation etc.)					●	●				
Remote Management					●					
Energy Charge Apportionment					●	●				
Monitor energy consumption					●					
Control third party products					●					
Integrate FGL A/C into BMS						●	●	●	●	
Interlock with door contact										●
Interlock with human sensor for meeting room										●

CONTROL SYSTEM OVERVIEW

User's needs are supported by offering a variety of controls, such as individual control, central control and building management control options.

Air Conditioning Individual Control

- Wired Remote Controller (Touch panel)**
UTY-RNRGZ5
- Wired Remote Controller**
UTY-RLRG
- Compact Wired Remote Controller**
UTY-RCRGZ1
UTY-RCRGZ1K
- Simple Remote Controller**
UTY-RSRG
UTY-RHRG Without operation mode
- Wireless Remote Controller**
UTY-LNHG
- IR Receiver Unit**
UTB-YWC For Duct type
- IR Receiver Unit**
UTY-LBHxD For Circular Flow Cassette

Air Conditioning Centralised Control

System controller (Software)
UTY-APGXZ1
UTY-ALGXZ1 (Lite edition)

Maximum controllable **1600*** indoor units

* Lite edition is maximum controllable 400 indoor units

NEW

Central Remote Controller
UTY-DCGGZ3

Maximum controllable **100** indoor units



Converter / Adaptor For external device

- BACnet® Gateway**
UTY-ABGXZ1 (Software)
- BACnet® Gateway**
VTY-VBGX (Hardware)
- Network Converter For LonWorks®**
UTY-VLGX
- MODBUS® Converter**
UTY-VMGX (Hardware)
- MODBUS® Interface**
FJ-RC-MBS-1
- KNX® Converter**
UTY-VKGX (Hardware)
- KNX® Interface**
FJ-RC-KNX-1i
- Wireless LAN Adaptor**
FJ-RC-WIFI-1
- External Switch Controller**
UTY-TERX

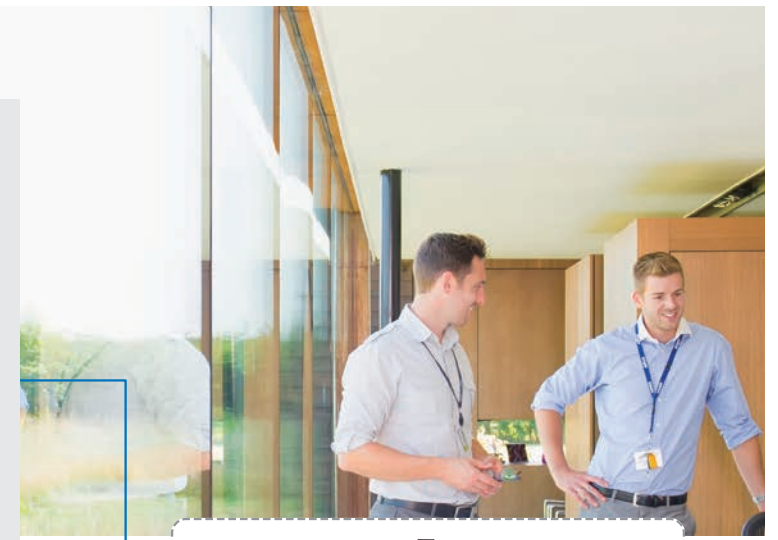

BMS / BAS*2

BMS, Home automation system

*1. USB Adaptor: Echelon™ U10 USB Network Interface
*2. BMS/BAS: Building Management System/Building Automation System











Converter / Adaptor For system expansion

- Network Converter (DC power supply)**
UTY-VTGX
- Network Converter (AC power supply)**
UTY-VTGXV
- Signal Amplifier**
UTY-VSGXZ1
- Thermostat Converter**
UTY-TTRXZ1

Card-key (Field supplied)

Internet device

COMPARISON TABLE OF CONTROLLERS

Item											
	Wired Remote Controller (Touch panel)	Wired Remote Controller	Compact Wired Remote Controller	Compact Wired Remote Controller	Simple Remote Controller	Simple Remote Controller*	Wireless Remote Controller	Central Remote Controller	System Controller Lite <small>Software</small>	System Controller <small>Software</small>	
Model name	UTY-RNRGZ5	UTY-RLRG	UTY-RCRGZ1	UTY-RCRGZ1	UTY-RSRG	UTY-RHRG	UTY-LNHG	UTY-DCGGZ3	UTY-ALGXZ1	UTY-APGXZ1	
Max. controllable remote controller groups	1	1	1	1	1	1	1	100	400	1600	
Max. controllable indoor units	16	16	1	1	16	16	16	100	400	1600	
Max. controllable groups	-	-	-	-	-	-	-	50	400	1600	
Air conditioning control function	On / Off	●	●	●	●	●	●	●	●	●	
	Operation mode setting	●	●	●	●	●	-	●	●	●	
	Fan speed setting	●	●	●	●	●	●	●	●	●	
	Room temp. setting	●	●	●	●	●	●	●	●	●	
	Room temp. set point limitation	●	●	-	-	●	●	-	●	●	
	Test operation	●	●	●	●	●	●	-	-	-	
	Up/down air direction flap setting	●	●	●	●	●	●	●	●	●	
	Right/left air direction flap setting	●	●	●	●	-	-	●	●	●	
	Individual louver control	●	-	●	●	-	-	-	●*4	-	
	Group setting	-	-	-	-	-	-	-	●	●	
	RC prohibition	-	-	-	-	-	-	-	●	●	
	Anti freeze setting	●	-	●	●	-	-	-	●	●	
	Set temp. auto return	●	●	-	-	-	-	-	-	-	
	Economy mode setting	●	●	●	●	-	-	●	●	●	
	Human sensor control	●	-	-	-	-	-	-	●	●	
Display	Error	●	●	●	●	●	-	●	●	●	
	Defrosting	●	●	●	●	●	-	●	●	●	
	Current time	●	●	-	-	-	●	●	●	●	
	Day of the week	●	●	-	-	-	-	●	●	●	
	R.C. prohibition	●	●	●	●	●	-	●	●	●	
	Address display	●	●	●	●	●	-	-	●	●	
	Room temp	●	-	●	●	●	-	●*3	●*3	●*3	
	Multi-language	●	-	-	-	-	-	●	●	●	
	Summer time	●	-	-	-	-	-	●	●	●	
	Name registration	●	-	-	-	-	-	●	●	●	
	Backlight	●	-	●	●	●	●	●	-	-	
	2D floor layout / 3D building display	-	-	-	-	-	-	-	-	●	
	Refrigerant leakage detection function	-	-	-	-	-	-	-	●	●	
	Timer	Schedule timer	Period	Week	Week	-	-	-	Week	Year	Year
			On/off, Temp, Mode, Low noise mode*3, Times per day	8	4	-	-	-	20	144	144
On/off timer		●	●	● (OFF only)	● (OFF only)	-	-	●	-	-	
Sleep timer		-	-	-	-	-	●	-	-	-	
Program timer		-	-	-	-	-	●	-	-	-	
Auto off timer		●	●	-	-	-	-	●	-	-	
Day off		●	●	-	-	-	-	●	●	●	
Min. unit of timer setting (Minutes)	10 • 30	30	-	-	-	5	10	10	10		
Control	Status monitoring system	-	-	-	-	-	-	●	●	●	
	Electricity charge apportionment	-	-	-	-	-	-	-	○	●	
	Error history	●	●	-	-	-	-	●	●	●	
	Emergency stop	-	-	-	-	-	-	●*2	-	-	
	Remote management	-	-	-	-	-	-	●	○	●	
	Energy saving management	-	-	-	-	-	-	-	○	○	
	E-mail notification for malfunction	-	-	-	-	-	-	●	●	●	
	Key lock	●	●	-	-	-	-	●	●	●	
Low noise mode	Child lock	Child lock	-	-	-	-	Password setting	Password setting	Password setting		

*1 "Operation mode" setting is not available for this model. *2 This function is available only through external input control.
 *3 This function is available only when using wired remote controller. *4 Equipped only with individual air volume batch reset. *5 UTY-DCGGZ3 only
 ●: Supported ○: Optional function -: Not supported yet

Wired remote controller (with touch panel)

UTY-RNRGZ5



Up to **16** indoor units
Up to **1** group

Easy operation by high-definition large STN-LCD touch panel screen

- Easy finger touch operation with LCD panel
- Built-in weekly/Daily timer (ON/OFF, Temp., Mode)
- Backlight enables easy operation in a darkened room
- Room temperature display
- Control up to 16 indoor units
- Corresponds to 12 different languages (English, Chinese, French, German, Spanish, Russian, Polish, Italian, Greek, Portuguese, Turkish and Dutch)
- 2-wire type

High performance and compact size

- In addition to the individual control, various energy saving controls can be realized using one remote controller only.



Accurate and comfortable control

- Indoor temperature can be detected accurately by the inclusion of a thermo sensor in the body of the wired controller.

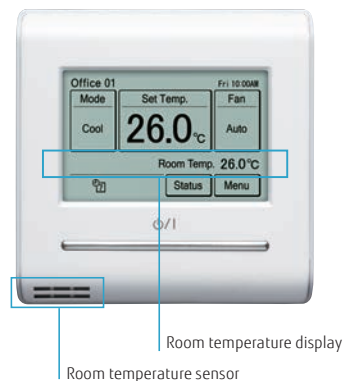

Various energy saving control

Custom Auto

- Maintains 2 separate set points for heating and cooling.
- Automatically changes mode between heating and cooling.

* This function is not available for some models.

Cooling set temp. 27°C, Heating set temp. 26°C

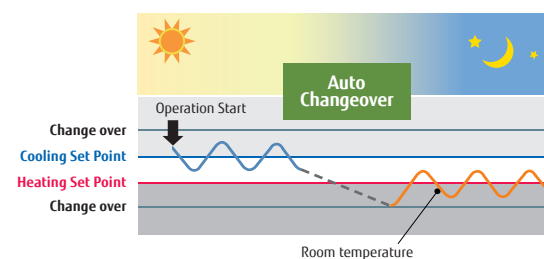

Auto OFF timer

- The indoor unit automatically is turned off when it reaches to the preset operating time frame.
- The time frame of the "Auto off timer" can be flexibly scheduled.
- Can be set off time 30 to 240 minutes

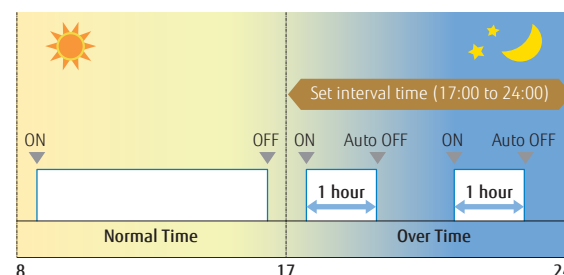

Ex.) At interval time hour (17:00 to 24:00) to prevent forgetting to turn off
Set off time : 1 hour

2 schedules Weekly Timer

Set Temperature Auto Return

Set Temperature Upper and Lower Limit Setting

Features: Wired remote controller (with touch panel)

Various energy saving control

Displays setting status and Limitations

- The remote controller settings can be easily checked

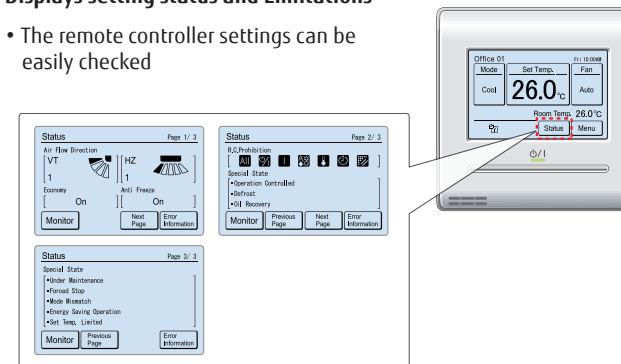

Summer Time display

- This function can be set easily from Menu screen

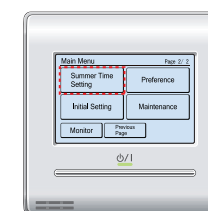

Child lock

- Lock / unlock method: Push the ON/OFF button and the screen (4 seconds)

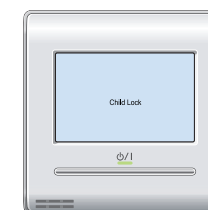

Name Registration

- Remote controller names can be registered in the remote controller screen. This makes it easy to identify the indoor unit you want to control in the room.

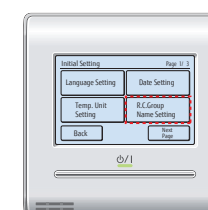

Backlight

- Backlight enable easy operation in a darkened room.
- For the lighting time of Backlight, 30 or 60 seconds can be set.
- Backlight activates while the buttons are operated and goes off 30 or 60 seconds after the operation stops.

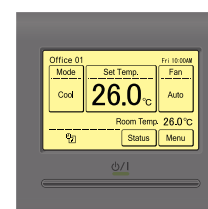

Specifications

Model name	UTY-RNRGZ5	
Power Supply	DC 12V	
Dimensions (H x W x D)	mm	120 x 120 x 20.4
Weight	g	220

DC12V is supplied by indoor unit.

Simplified installation

Uses non-polar 2-wire type

- The faulty wiring can be prevented by using non-polar 2-wire.

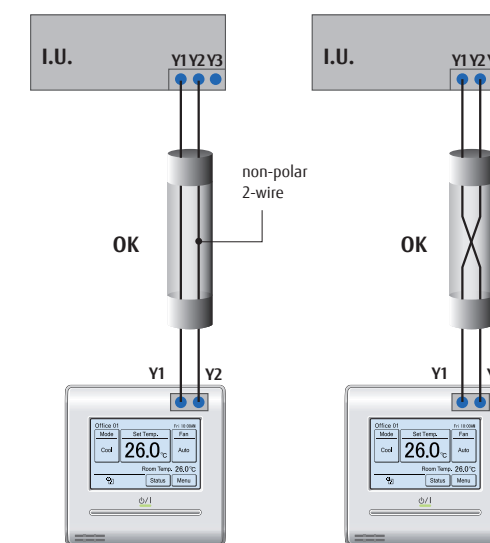

Auto Address Setting/Setting Position Notification

- Reduce errors and install time compared with the current specification Rotary SW
- When will be set remote controller groups, can also be set automatically new Wired remote controller address
- After auto address setting of new wired remote controller groups, what number can also confirm addresses

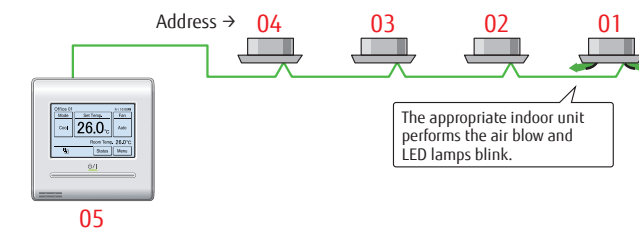

Easy Maintenance

Error History Display

- The errors that occur in the indoor unit or remote controller are saved as a history.
- A maximum of 32 error incidents can be saved.

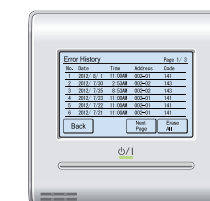

Wired remote controller

UTY-RLRG



- Various timer setup (ON / OFF / WEEKLY) are possible.
- The room temperature can be controlled by detecting the temperature accurately with Built-in thermo sensor.
- When a failure occurs, the error code is displayed.
- Error history. (Last 16 error codes can be accessed.)
- 2-wire type

Up to
16 indoor units
Up to
1 group

High performance and compact size

- In addition to the individual control, various energy saving controls can be realized using one remote controller only.



Visually intuitive operation

- The operation mode, set temperature, and fan speed are shown prominently on the top screen.
- Each function to be set is indicated by an icon.
- The control guide makes it simple and straightforward to operate a remote controller.

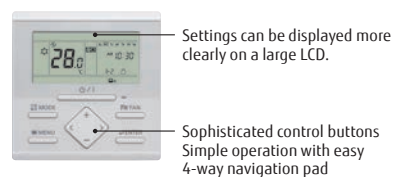

Auto-off timer

- The indoor unit automatically turns off after a set time has passed.

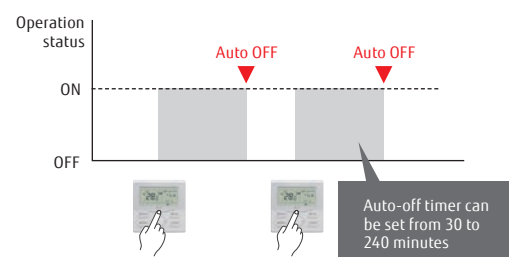

Set temperature auto return

- The setting temperature automatically returns to the previously set temperature.
- The time range in which the set temperature can be changed is 30 to 240 minutes.

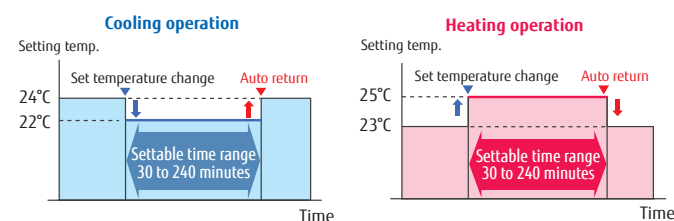

Specifications

Model name	UTY-RLRG	
Power Supply	DC 12V	
Dimensions (H x W x D)	mm	120 x 120 x 17
Weight	g	170

DC12V is supplied by indoor unit.

Compact wired remote controller

UTY-RCRGZ1 / UTY-RCRGZ1K



UTY-RCRGZ1

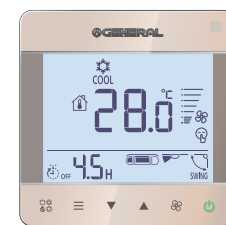

UTY-RCRGZ1K

Up to
1 indoor units
Up to
1 group

- Simple design to match the stylish interior
- Easy to install : Body of controller is designed to fit in European standard junction box
- Can be operated both by wireless and wired remote controller.
- 2-wire type

Large screen and simple display

- Although the size is compact, the screen is large
- Large letters makes it easy to see
- Operation is simple and easy-to-understand

- 1 Visible large letter
- 2 Touch key (Frequently-used operation is placed on the direct button)
- 3 Operation mode
- 4 Menu
- 5 Air flow
- 6 Built in IR receiver
- 7 LCD with backlight is clearly visible in the dark
- 8 Easy-to-understand pictograph display
- 9 LED is mounted for the ON/OFF key (Green light on when R.C. is turned on)

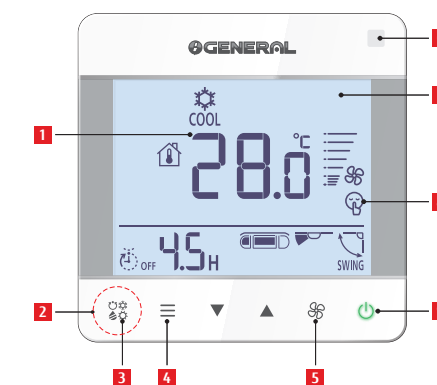

System overview

• VRF connection

One indoor unit and one remote controller are connected in one non-polar and 2-wire remote controller system.

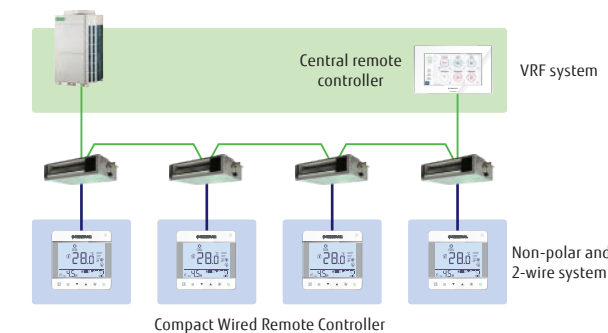

• RAC (Room air conditioner) connection

One indoor unit and one remote controller are connected in one non-polar and 2-wire remote controller system.

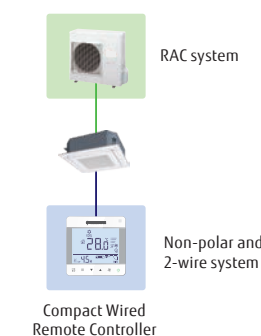

Specifications

Model name	UTY-RCRGZ1		UTY-RCRGZ1K	
Power Supply	DC 12V			
Dimensions (H x W x D)	mm	86 x 86 x 44		
Weight	g	135		

DC12V is supplied by indoor unit.

Simple remote controller

UTY-RSRG / UTY-RHRG (without operation mode)

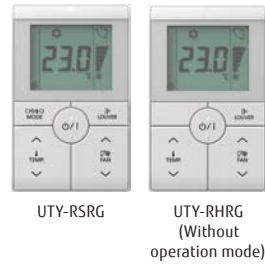

Up to
16 indoor units
Up to
1 group

Compact remote controller provides access to basic functions

- Up to 16 indoor units can be controlled with one remote controller.
- Suitable for hotels or offices as it is easily operated with no complex functions.
- Stylish design: Simple design to match the stylish interior.
- Large LCD screen & simple operation buttons
- Backlight: White colored backlight on monitor enable easy operation in dark.
- 2-wire type

Corresponding to various applications

• Vertical louver control:

Vertical airflow direction can be adjusted for Duct types with auto louver and Cassette types, which are installed in hotels and conference rooms, can be adjusted.



• Room temperature set point limitation:

The Simple Remote Controller can manage to energy saving operation in small buildings without the central control unit.

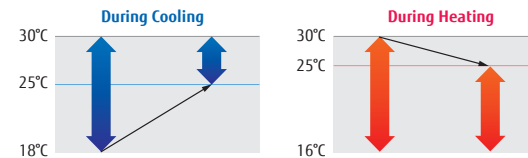

• Built in room temperature sensor:

The Simple Remote Controller detects actual room temperature and controls room climate accuracy.

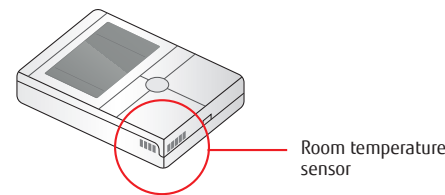

Specifications

Model name	UTY-RSRG		UTY-RHRG	
Power Supply	DC 12V			
Dimensions (H x W x D)	mm	120 x 75 x 19.4		
Weight	g	120		

Wireless remote controller

UTY-LNHG



Up to
16 indoor units
Up to
1 group
Up to
4 different daily timers

Simple and sophisticated operations with a choice of 4 daily timers

- A single controller controls up to 16 indoor units.

Built-in daily timer

Select from 4 different timer programs : On / Off / Program / Sleep

Program timer : The program timer operates the ON and OFF timer once within a 24 hour period.

Sleep timer : The sleep timer function automatically corrects the set temperature according to the time setting to prevent excessive cooling or heating during sleep hours.

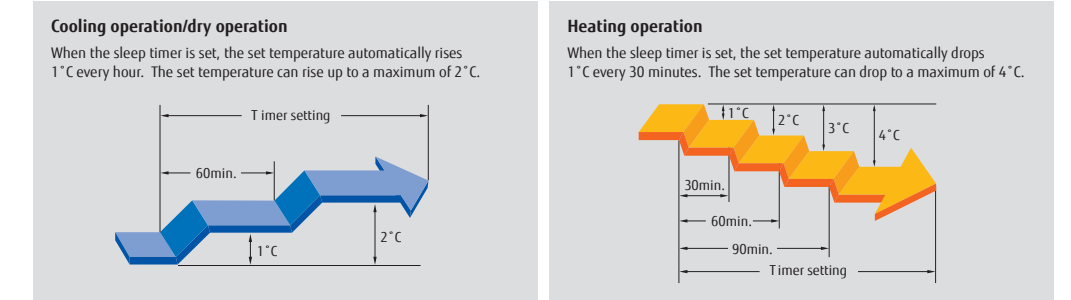

Easy installation and operation

Code selector switch prevents indoor unit mix-up. (Up to 4 codes can be set.)

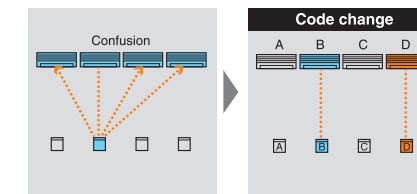

Wide and precise

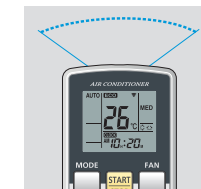

Address setting

During installation work, address setting can be performed using the Wireless Remote Controller, thus eliminating manual switch setting.

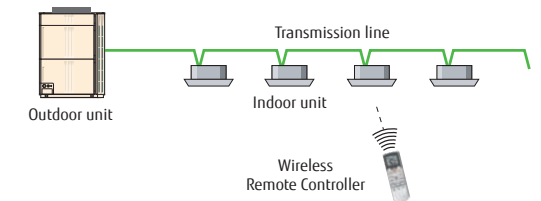

Specifications

Model name	UTY-LNHG	
Power Supply	1.5V (R03 / LR03 / AAA) x 2	
Dimensions (H x W x D)	mm	170 x 56 x 19
Weight	g	85

IR receiver unit for duct type

UTB-YWC

Duct type* indoor units can be controlled with Wireless Remote Controller

*Only Large Airflow Duct cannot be connected to IR Receiver Unit.

- Up to 16 indoor units can be controlled with one remote controller.
- Suitable for hotels or offices as it is easily operated with no complex functions.

Wiring connection

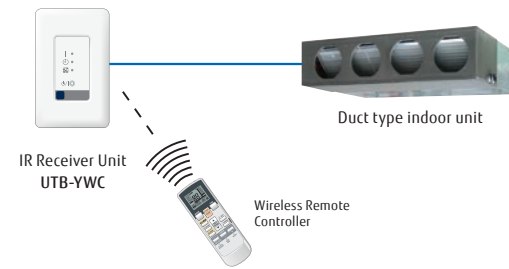

Specifications

< Wireless Remote Controller >

Model name	UTB-YWC	
Power Supply	1.5 V (R03/LR03/AAA)	
Dimensions (H x W x D)	mm	170 x 56 x 19
Weight	g	85

< IR Receiver Unit >

Battery	DC 5V	
Dimensions (H x W x D)	mm	145 x 90 x 30
Weight	g	150

IR receiver unit for Cassette

UTY-LBHxD

Cassette type indoor unit can be controlled with Wireless Remote Controller

Wiring connection

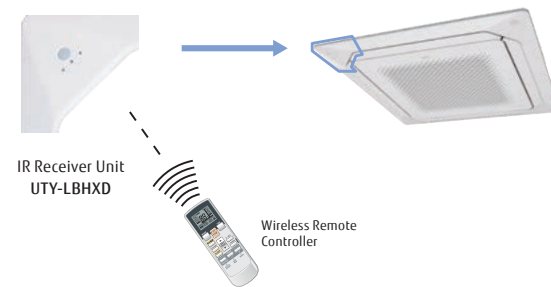

Specifications

< Wireless Remote Controller >

Model name	UTY-LBHxD	
Power Supply	1.5 V (R03/LR03/AAA)	
Dimensions (H x W x D)	mm	170 x 56 x 19
Weight	g	85

< IR Receiver Unit >

Battery	DC 5V	
Dimensions (H x W x D)	mm	193.9 x 193.9 x 31.2
Weight	g	140



NEW Central remote controller
UTY-DCGGZ3



Up to **100** indoor units
Up to **50** groups

For tenants in small to midsize commercial premises

- Individual control and monitoring of up to 100 indoor units
- 7.0inch TFT color screen
- Visually intuitive operation
- Room temperature display by indoor unit sensor & remote controller sensor
- 50 Remote Controller Groups Display & remote controller group rename
- Supports 14 languages: Chinese (Simplified/Traditional), Dutch, English, French, German, Greek, Italian, Polish, Portuguese, Russian, Spanish, Turkish, and Thai (Remote Management only)

Easy Management

Air conditioning management by detecting room temperatures of each room

The room temperature detected with indoor unit sensor or remote controller sensor can be displayed. New model can detect the room temperature by indoor units sensors even if wired remote controllers are not connected to the indoor units.



50 Remote Controller Groups Display

The group display and the 50 remote controller groups display can be switched easily. Users can choose which display is better, depending on the situation.

Group Display



Manage & Monitor by each Groups

50 Remote Controller Groups Display

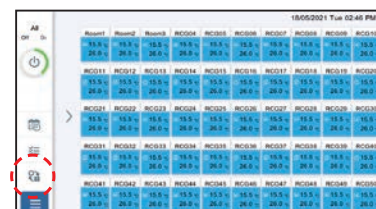

Manage & Monitor by 50 Remote Controller Groups



Remote Controller Groups Rename

The remote controller group names can be changed. Users can know easily where the air conditioning is located by changing the remote controller group names.

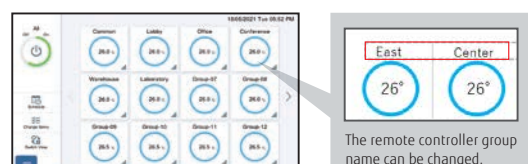

Features: Central Remote Controller

- Easy intuitive operation from the touch panel display.
- All functions can be accessed through the monitoring screen showing a pop-up window for detailed operation.

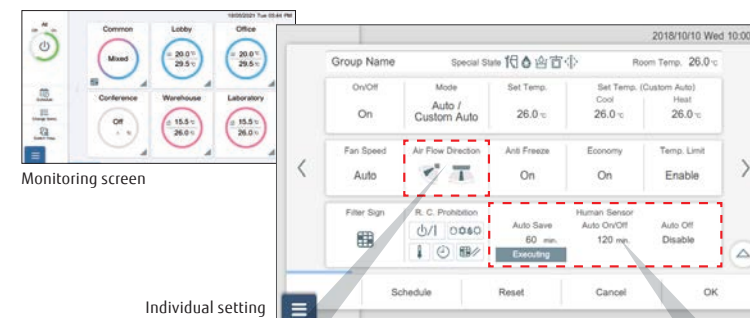

Added individual wind direction control
Individual wind direction control has been added.
Circular Flow cassette / 3D Flow cassette

Human Sensor Compatible
Human sensor setting
• Auto save
• Auto on / off
• Auto off detection time
• Enable and disable

Remote Management

Remote monitoring / Remote operation

New central remote controller can control your tenant's air conditioner anytime and anywhere. When the central remote controller manages the indoor units of some tenants, air conditioning of each tenants can be managed separately online.

Increased the Number of Accounts

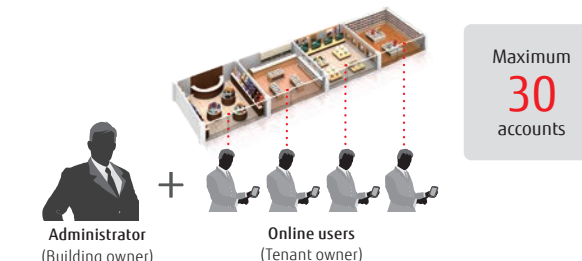

Trouble support function

Display error details
Display descriptive explanation when an error occurs



Sensor value monitoring function

Monitor sensor data of indoor unit / outdoor unit, send mail

Notify room temperature by email*

Notify by e-mail when the temperature around the air conditioner is too high or too low

*:This function is available only when using wired remote controller.

NEW Remote Management

Annual schedule

- An annual schedule can be arranged for each remote controller group or user-defined group.
- Allows for the programming of special settings for weekends, holidays, and store closings throughout the year.

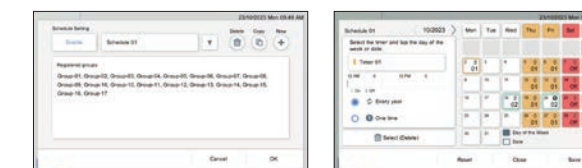

low noise schedule

Low noise operation of outdoor units can be scheduled.



Automatic return to set temperature

A function that automatically returns the changed temperature to its original value over time.

Specifications

Model name	UTY-DCGGZ3	
Power Supply	100-240 V 50 / 60 Hz	
Dimensions (H x W x D)	mm	134,6 × 216,2 × 37,9
Weight	g	800

System controller

UTY-APGXZ1 **Software**

Up to
4 VRF network systems
Up to
400 outdoor units
Up to
1,600 indoor units

System controller enables advanced integrated monitoring and control of VRF network systems operating in small to large buildings.

- Up to 1,600 indoor units and 400 outdoor units on up to 4 VRF network systems can be controlled.
- To accommodate facility management needs, the system controller offers—in addition to precise air conditioning control—remote central control, electricity charge apportionment, schedule management, and energy-saving options for VRF network systems.
- Supports 7 languages: Chinese, English, French, German, Polish, Russian, and Spanish.



System controller lite

UTY-ALGXZ1 **Software**

Up to
1 VRF network systems
Up to
100 outdoor units
Up to
400 indoor units

System controller Lite offers a set of standard functions to manage air conditioners operating in a small or midsize building.

- Up to 400 indoor units and 100 outdoor units on a VRF network system can be controlled.
- In addition to precise air conditioning control, a variety of applications are available as options to offer a wider range of control.
- Supports 7 languages: Chinese, English, French, German, Polish, Russian, and Spanish.



Features: System controller / System controller lite

3rd party devices connected by Modbus can be controlled.

Standard for System Controller **Option** for System controller Lite UTY-PLGXX2

When a MODBUS® adapter (locally available) is connected to a computer, electrical equipment and devices supported by MODBUS® can be monitored and controlled centrally from the computer. The central control can reduce wasted energy throughout an entire building resulting from a failure to turn equipment off during or after work, as well as reduce the need for on-site patrols.

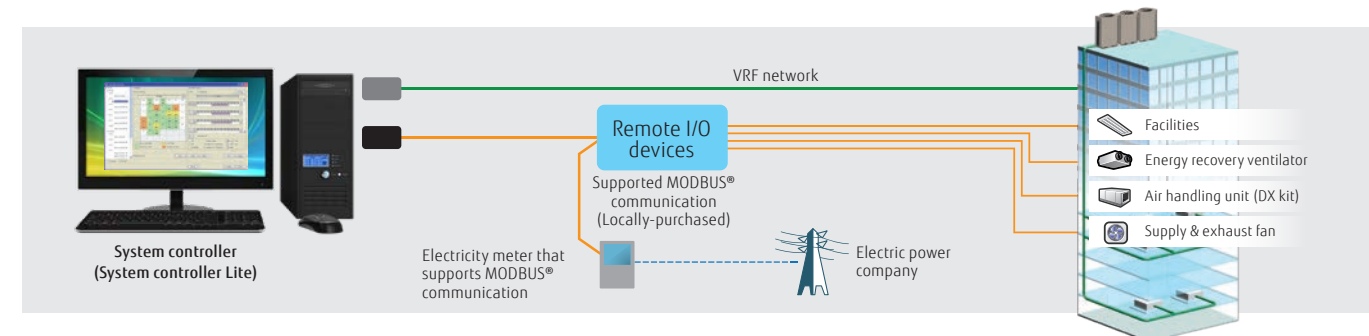

Wide-ranging operation and data management

Standard System controller and System controller Lite

Schedule management

- An annual schedule can be arranged for each remote controller group or user-defined group.
- ON/OFF, operation mode, remote controller prohibition, and temperature settings can be programmed for up to 143 times per day at 10-minute intervals and for up to 101 configurations for each remote controller group.
- Settings can be programmed for a period that spans midnight.
- Allows for the programming of special settings for weekends, holidays, and store closings throughout the year.
- Low noise operation of outdoor units can be scheduled.

Wide-ranging control of indoor and outdoor units

- The operation status and mode of each indoor unit are displayed.
- Turn on and off each indoor unit and switch its operation mode.
- Setting temperature range limitation
- Low noise setting of outdoor units

Remote controller prohibition

Prohibits the operation mode, temperature setting, or ON/OFF of an indoor unit.

Error alert and e-mail notice

When something goes wrong, an error message is shown in a popup on a computer display with a chime, and an e-mail notice is sent. Errors of the past one year are logged and can be reviewed.

Operation and control history

A history of operation status and control can be maintained and retrieved.

Importing and exporting databases

Only an administrator is authorized to import and export registration, layout, and image data.

Automatic clock adjustment

Time can be set for all controllers in batch automatically.

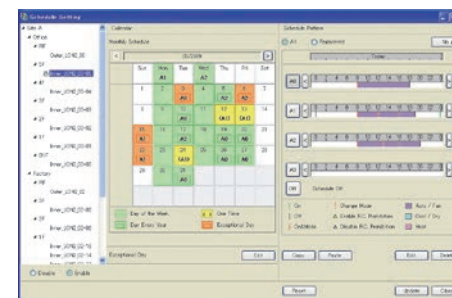

Visually intuitive operation

• **Click & Operate** : The property is shown visually from the perspective most suitable for operation and operated accordingly (Click & Operate). You can select from among the 4 displays of site, building, floor, or list.

• **Freely define groups for batched control** : Indoor units can be freely grouped for simple batched control from a tree menu. Grouping by hierarchical structure, such as by section, division or department is possible.

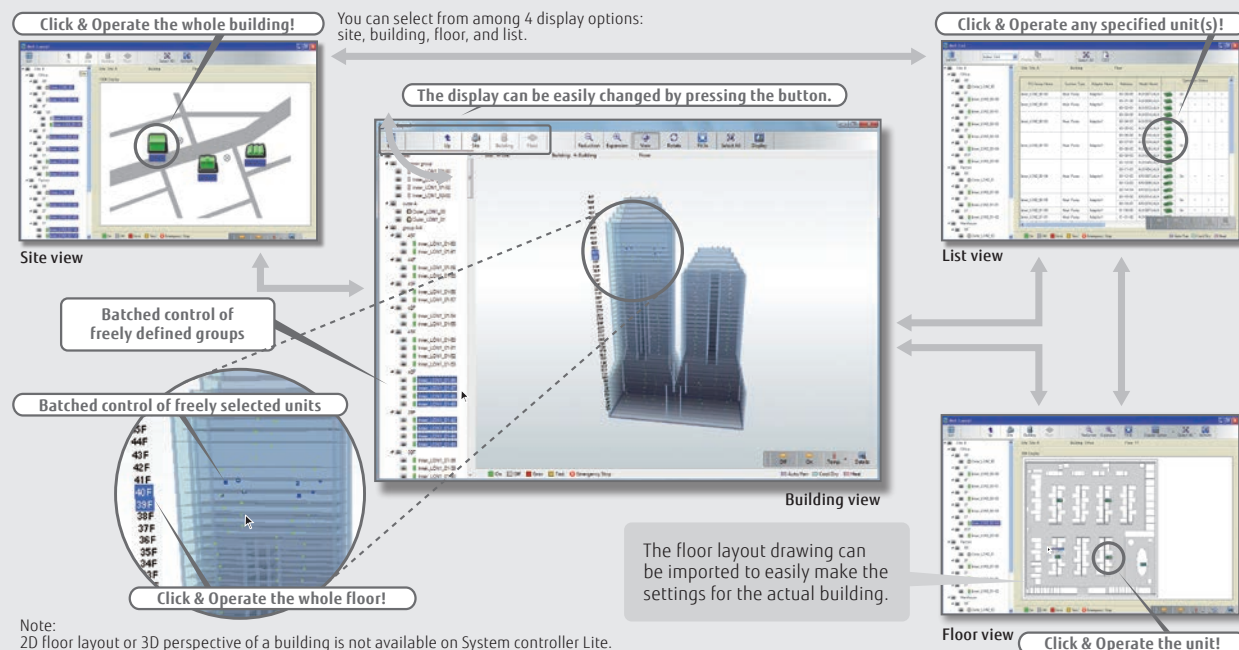

Electricity charge apportionment

Standard on System controller
Option System controller Lite UTY-PLGXA2

Electricity charge apportionment method

This is a method to calculate monthly energy costs to be allocated to each tenant based on the amount of energy used by their air conditioners. The first step is to determine exactly how much energy is consumed by air conditioners in each tenant space. The second step is to divide the total energy charge billed by an electric power company based on the amount of energy used by each tenant to determine the energy cost to be allocated to each of them. (See figure on right)

The calculation takes into consideration such factors as the number of unused rooms and nighttime electricity rate, which are shown in detail on an energy cost allocation schedule.

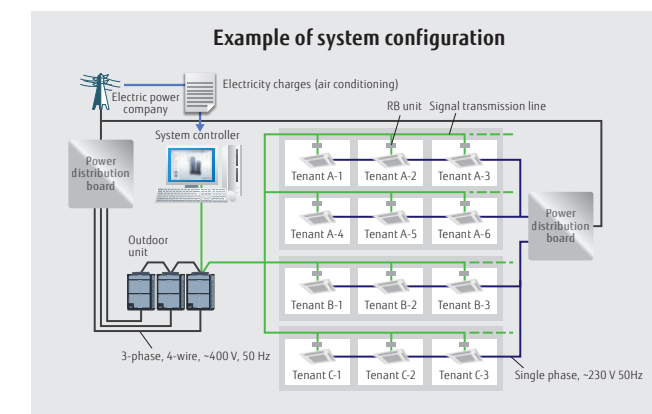

VRF Control Systems Centralized Controller

Features: System controller / System controller lite

Remote monitoring management

- Standard** on System controller
- Option** System controller Lite UTY-PLGXR2

The System controller can be used on site or remotely over networks for remote central control. The System controller requires 2 software programs working together: The VRF controller runs on site and communicates with the VRF system; The VRF explorer, which runs at a remote location, provides a user interface and communicates with the VRF controller. The VRF controller and the VRF explorer run on a single computer or on different computers connected on a network. A computer running VRF explorer can centrally control up to 10 VRF system sites having up to 20 buildings each.

On site central control

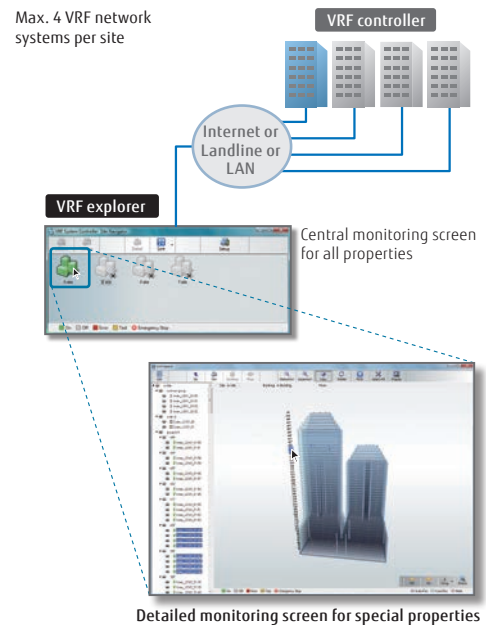

Remote central control

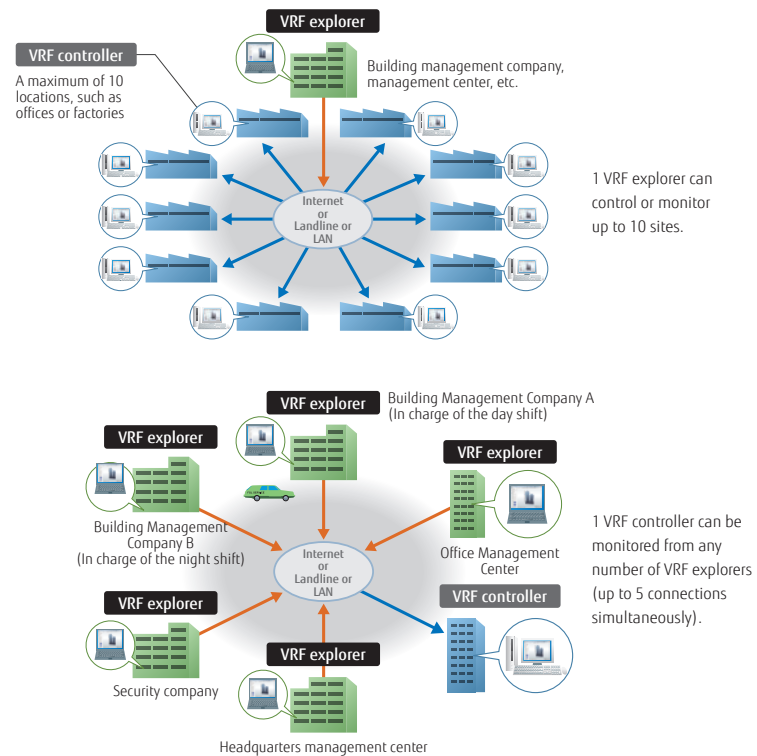

Energy-saving management

- Option** System controller UTY-PEGXZ1
- Option** System controller Lite UTY-PLGXE2

A variety of energy-saving options can be selected depending on the season, weather, and time of day. Excellent energy-saving operation is performed while keeping users comfortable.

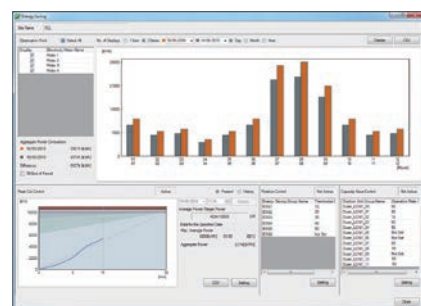

Main screen for energy-saving management

Energy saving graph data: This chart compares the energy consumption for the current month with the previous month and with the same month of the previous year to keep track of the energy-saving performance.

Indoor unit rotation

Indoor units can be automatically rotated to operate within a group in accordance with a predetermined annual schedule to reduce power consumption while keeping users comfortable. The operation stoppage rate can be selected for an indoor unit.

Peak-cut mode

The system controller monitors the connected power meter and controls the energy to maintain the target power consumption set for each time period by changing the set temperature of the indoor units or turning off the thermostat so as to keep the users comfortable. Indoor units to be controlled can be grouped in many ways, and the control level can be set for each group.

Capacity saving for outdoor unit

The upper limit on the capacity of an outdoor unit can be adjusted to reduce power consumption during a hot summer or cold winter by averaging out the power-saving performance of each refrigerant system. The upper limit on capacity can be set at 50% of the rated capacity or more.

Summary of functions

Functions	Type	System controller		System controller Lite				
		UTY-APGXZ1	Option UTY-PEGXZ1	UTY-ALGXZ1	Option UTY-PLGXR2	Option UTY-PLGXA2	Option UTY-PLGXE2	Option UTY-PLGXX2
Specifications	Max. number of VRF networks supported	4	—	1	—	—	—	—
	Max. number of indoor unit and remote controller groups per VRF network	400	—	400	—	—	—	—
	Max. number of outdoor units per VRF network	100	—	100	—	—	—	—
	Max. number of indoor units and remote controller groups per System controller	1600	—	400	—	—	—	—
Site supervision	Multiple site display	10	—	10	—	—	—	—
	Number of buildings per site	20	—	—	—	—	—	—
	Number of floors per site	200	—	—	—	—	—	—
	Number of floors per building	50	—	—	—	—	—	—
	3D graphical layout view	●	—	—	—	—	—	—
	2D graphical layout view	●	—	—	—	—	—	—
	List display	●	—	●	—	—	—	—
	Tree display	●	—	—	—	—	—	—
	Group display	●	—	●	—	—	—	—
	Error notification	●	—	●	—	—	—	—
Error management	Audible alarm	●	—	●	—	—	—	—
	E-mail notification of errors	●	—	●	—	—	—	—
	Error history	●	—	●	—	—	—	—
History	Operation history	●	—	●	—	—	—	—
	Control history	●	—	●	—	—	—	—
Operation control	Individual control	ON/OFF	●	—	●	—	—	—
		Operation mode*	●	—	●	—	—	—
		Room temperature	●	—	●	—	—	—
		Fan speed	●	—	●	—	—	—
		Airflow direction	●	—	●	—	—	—
		Economy mode	●	—	●	—	—	—
		Setting temperature range limitation	●	—	●	—	—	—
	Anti-freeze	●	—	●	—	—	—	
	Individual management	Low noise setting of outdoor units	●	—	●	—	—	—
		Remote controller prohibition	●	—	●	—	—	—
	Other	Setting temperature range limitation	●	—	●	—	—	—
		Filter sign reset	●	—	●	—	—	—
	Schedule	memory operations	●	—	●	—	—	—
Pattern operations		●	—	●	—	—	—	
Schedule	Annual Schedule	●	—	●	—	—	—	
	Setting for a specific date	●	—	●	—	—	—	
	ON/OFF per day	72	—	72	—	—	—	
	ON/OFF per week	504	—	504	—	—	—	
	Day off	●	—	●	—	—	—	
	Minimum unit of timer setting (minutes)	10	—	10	—	—	—	
	Weekly schedule for low noise mode	●	—	●	—	—	—	
Remote monitoring management	Web Operation	●	—	●	—	—	—	
	Remote monitoring	●	—	●	—	—	—	
	Remote operation control	●	—	●	—	—	—	
	Remote function setting	●	—	●	—	—	—	
Electricity charge apportionment	Apportionment charge/bill calculation	●	—	●	—	—	—	
	Tenant (block) setting	●	—	●	—	—	—	
	Common facilities apportionment setting	●	—	●	—	—	—	
	Rated power consumption allotment	●	—	●	—	—	—	
Energy-saving management	Individual calculations for cooling and heating	—	●	—	●	—	—	
	Electricity meter supported	—	●	—	●	—	—	
	Indoor unit rotation	—	●	—	●	—	—	
	Peak cut control	—	●	—	●	—	—	
	Capacity saving for outdoor unit	—	●	—	●	—	—	
Control of external devices	Record of energy-saving operation	—	●	—	●	—	—	
	Information on energy saving	—	●	—	●	—	—	
	Power consumption monitor	—	●	—	●	—	—	
	Electricity meter supported	—	●	—	●	—	—	
Others	Monitor	●	—	●	—	—	—	
	Control	●	—	●	—	—	—	
Others	Importing and exporting databases	●	—	●	—	—	—	
	Automatic clock adjustment	●	—	●	—	—	—	
	Multiple language support	7 languages	—	7 languages	—	—	—	
	Refrigerant leak detector	●	—	●	—	—	—	
	Power shutdown	●	—	●	—	—	—	

●●: Available - : Not available

Computer requirements

The specifications required for the computer are shown in the table below:

	System controller	System controller Lite
Operating system	<ul style="list-style-type: none"> Microsoft® Windows® 7 Home Premium (32-bit or 64-bit) SP1, Windows® 7 Professional (32-bit or 64-bit) SP1 Microsoft® Windows® 8.1 (32-bit or 64-bit), Windows® 8.1 Pro (32-bit or 64-bit) Microsoft® Windows® 10 Home (32-bit or 64-bit), Windows® 10 Pro (32-bit or 64-bit) Supports 7 languages: English, Chinese, French, German, Russian, Spanish, and Polish	<ul style="list-style-type: none"> Ethernet port (for getting access to the internet using LAN) or a modem (for getting access to the internet via landline)
CPU	Intel® Core™ i3 2 GHz or higher	
Memory	<ul style="list-style-type: none"> 2 GB or more (for Windows® 7 [32-bit]) 4 GB or more (for Windows® 7 [64-bit], Window : ® 8.1, and Windows® 10) 	
HDD	40 GB or more of free space	
Displayed items	1024 × 768 or higher resolution	
Interfaces	<ul style="list-style-type: none"> Ethernet port (for getting access to the internet using LAN) or a modem (for getting access to the internet via landline) Up to 6 USB ports (Only required for a server computer working as a VRF controller) - Maximum of 2 USB ports are required to connect to a White-USB-key/WibuKey - Up to 4 USB ports required to connect to an Echelon® U10 USB network interface * Maximum number of required USB ports depends on the applicable system configuration. 	<ul style="list-style-type: none"> Ethernet port (for getting access to the internet using LAN) or a modem (for getting access to the internet via landline) Up to 6 USB ports (Only required for a server computer working as a VRF controller) - Maximum of 4 USB ports are required to connect to a White-USB-key/WibuKey - 1 USB port is required for an Ec ; helon® U10 USB Network interface * The maximum number of required USB ports depends on the applicable system configuration.
Graphic accelerator	Microsoft® DirectX® 9.0c compatible	
Software	Adobe® Acrobat Reader® 9.0 or later	

• Echelon® U10 USB Network interface - TP/FT-10 Channel (Model name: 75010R) (Required for each VRF Network)

<PACKING LIST>

Type	For System controller		For System controller Lite				
	System controller	Option Energy manager	System controller Lite	Remote access	Option Electricity charge apportionment	Option Energy saving	Option Centralized control
Model name	UTY-APGXZ1	UTY-PEGXZ1	UTY-ALGXZ1	UTY-PLGXR2	UTY-PLGXA2	UTY-PLGXE2	UTY-PLGXX2
White-USB-key	1	1	1	1	1	1	1

*1: Software protection key to be inserted in a USB slot running System controller or System controller Lite.

System controller or System controller Lite may only run on a PC with a WHITE-USB-KEY. However, a WHITE-USB-KEY is not required for remote VRF explorer software.

BACnet® gateway

UTY-ABGXZ1 **Software**



White-USB-key
(Software Protection Key)



BACnet® is a registered trademark of ASHRAE. ASHRAE does not endorse, approve or test products for compliance with ASHRAE standards. Compliance of listed products to the requirements of ASHRAE Standard 135 is the responsibility of BACnet International (BI). BTL is a registered trademark of BACnet International.

- Up to **4** VRF network systems
- Up to **400** outdoor units
- Up to **1,600** indoor units

- It is possible to connect medium to large sized BMS to VRF network system via BACnet®, a global standard for open networks.
- A maximum of 1600 indoor units with 4 VRF network systems (a maximum of 400 indoor units & 100 outdoor units for one network system) can be connected to one BACnet® Gateway.
- It is possible to control or monitor VRF network system from BMS via BACnet® Gateway.
- Compatible with BACnet® (ANSI / ASHRAE-135-2014) application specific controller (B-ASC).
- Compatible with BACnet®/IP over Ethernet.
- Scheduling function, Alarm & Event functions as well as Electricity Change Apportionment function are provided in BACnet® Gateway.
- Connection between VRF network system to personal computer is possible via small U10 USB interface. However, both U10 USB interface & personal computer are field supplied items.
- Corresponds to 7 different languages, English, Chinese, French, German, Spanish, Russian, Polish.

Installation example

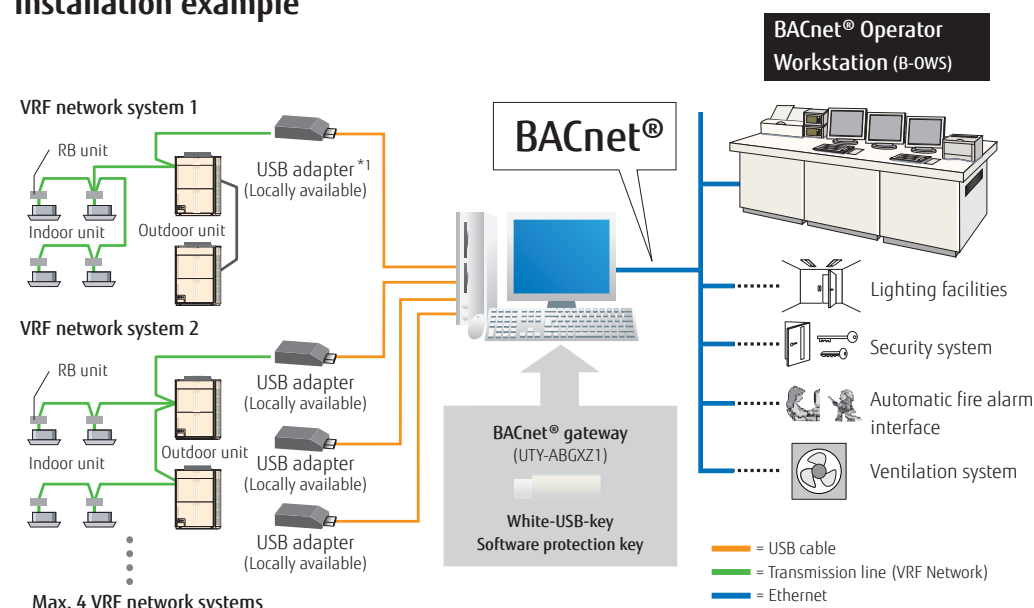

*1: U10 USB network interface available from Echelon® Corporation.

Specifications

	UTY-ABGXZ1
Operating system	<ul style="list-style-type: none"> • Microsoft® Windows® 7 Home Premium (32-bit or 64-bit) SP1, Windows® 7 Professional (32-bit or 64-bit) SP1 • Microsoft® Windows® 8.1 (32-bit or 64-bit), Windows® 8.1 Pro (32-bit or 64-bit) • Microsoft® Windows® 10 Home (32-bit or 64-bit), Windows® 10 Pro (32-bit or 64-bit) [Supported languages] English, Chinese, French, German, Russian, Spanish, and Polish
CPU	Intel® Core™ i3 2 GHz or higher
Memory	<ul style="list-style-type: none"> • 2 GB or more (for Windows® 7 [32-bit]) • 4 GB or more (for Windows® 7 [64-bit], Windows® 8.1, and Windows® 10)
HDD	40 GB or more of free space
Display	1024 x 768 or higher resolution
Interface	<ul style="list-style-type: none"> • Ethernet port (for getting access to the Internet using LAN) • USB ports (Maximum of 5 ports) - 1 USB port is required for WHITE-USB-KEY/WibuKey connection - Maximum of 4 USB ports are required for Echelon™ U10 USB Network Interface * Maximum number of required USB ports depends on the applicable system configurations.
Software	Adobe® Reader™ 9.0 or later

*Echelon™ U10 USB Network Interface – TP/FT-10 Channel (Model number: 75010R) (Required for each VRF Network.)

<PACKING LIST>

Name and shape	Quantity	Application
WHITE-USB-KEY	1	Includes the software and manuals, license for BACnet™ Gateway.

BACnet® gateway

UTY-VBGX **Hardware**



BACnet® is a registered trademark of ASHRAE. ASHRAE does not endorse, approve or test products for compliance with ASHRAE standards. Compliance of listed products to the requirements of ASHRAE Standard 135 is the responsibility of BACnet International (BI). BTL is a registered trademark of BACnet International.

- Up to **1** VRF network systems
- Up to **32** refrigerant systems
- Up to **128** indoor units

- BACnet® Gateway enables to connect a BMS and FG VRF system.
- A maximum of 128 indoor units and 32 refrigerant system can be connected to a single BACnet® Gateway.
- Compatible with BACnet® (ANSI / ASHRAE-135-2012) application specific controller (B-ASC).
- Compatible with BACnet®/IP over Ethernet.

Installation example

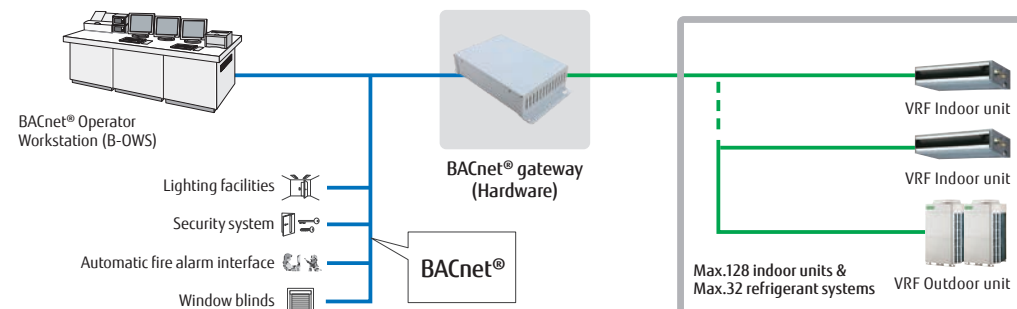

Specifications

Model name	UTY-VBGX
Number of controllable indoor units	128
Number of controllable refrigerant system	32
Number of controllable VRF network	1
Number of connectable units / one VRF network	4

Model name	UTY-VBGX	
Power Supply	100-240V 50/60Hz, single phase	
Power Consumption	W	4.6 (max)
Dimensions (H x W x D)	mm	59.6 × 270.4 × 176
Weight	g	1,200

Network converter for LONWORKS™

UTY-VLGX

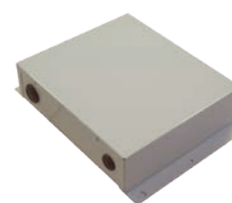

- Up to **4** units to BMS
- Up to **100** outdoor units
- Up to **128** indoor units

- For connection between VRF network system and a LONWORKS® open network for management of small to medium-sized BMS and VRF network system.
- The UTY-VLGX permits central monitoring and control of a VRF network system from a BMS through a LONWORKS® interface.
- Up to 128 Indoor units can be connected to one Network Converter for LONWORKS®

Installation example

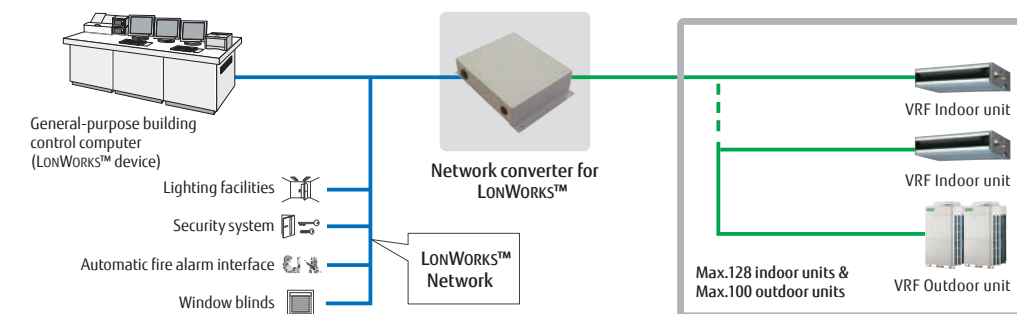

Specifications

Model name	UTY-VLGX	
Power Supply	208-240V 50/60Hz, Single phase	
Power Consumption	W	4.5
Dimensions (H x W x D)	mm	67 × 288 × 211
Weight	g	1,500

Transmission specifications (BMS side)

Transmission speed	78 kbps
Transceiver	FT-X1 (Echelon™ Corporation)
Transmission way form	Free topology
Terminal resistor	None (It attaches at the terminal of a network.)

MODBUS® convertor for VRF

UTY-VMGX **Hardware**



The MODBUS Converter allows a complete integration of air conditioners into MODBUS Networks.

- Compact and lightweight design
- Direct connection to MODBUS Network
- Up to 128 indoor units can be controlled in one MODBUS Converter
- The MODBUS Converter permits central monitoring and control of air conditioners from BMS or Central Controller.

Up to **9** units per VRF system
Up to **100** outdoor units
Up to **128** indoor units

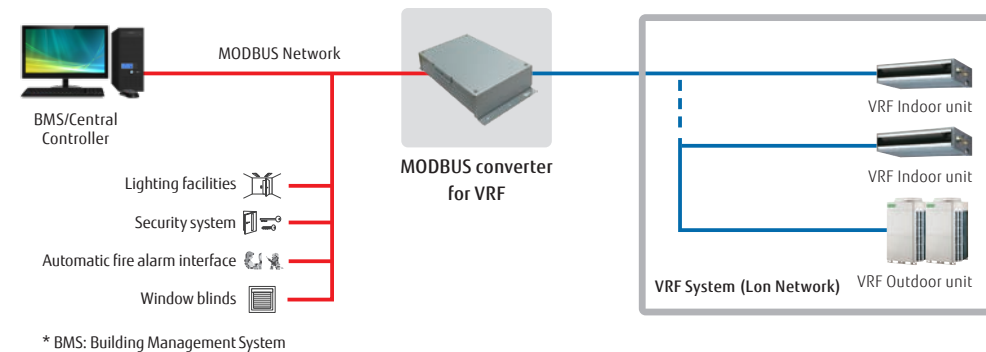

Specifications

Model name	UTY-VMGX	
Power Supply	220-240V 50/60Hz	
Input power	W	Max. 2
Dimensions (H x W x D)	mm	54 x 260 x 150
Weight	g	1,100

MODBUS® Interface

UTY-VKGX



The Modbus Interface allows a complete integration of air conditioners into Modbus Networks.

- Simple installation due to small and compact size.
- No separate external power supply required.
- The Modbus Interface permits central monitoring and control of air conditioners from BMS.

Up to **1** indoor unit

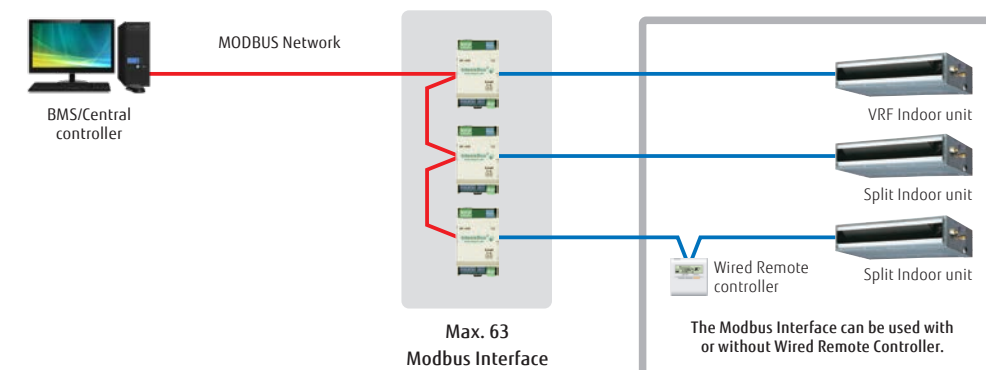

Specifications

Model name	FJ-RC-MBS-1	
Dimensions (H x W x D)	mm	93 x 53 x 58
Weight	g	85

KNX® converter for VRF

UTY-VKGX **Hardware**



It is possible to control the VRF system from central / home controller via KNX network.

- New KNX Converter enables to connect central/home controller and FG VRF system.
- A maximum of 128 indoor units and 100 outdoor units can be connected to single KNX Converter.

Up to **100** outdoor units
Up to **128** indoor units

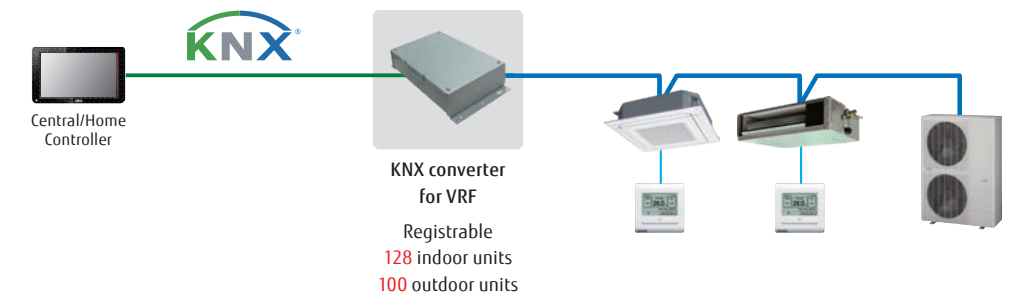

Specifications

Model name	UTY-VKGX	
Power Supply	220-240V 50/60Hz	
Input power	W	1.5
Dimensions (H x W x D)	mm	54 x 260 x 150
Weight	g	1,200

KNX® Interface

FJ-RC-KNX-1i



The KNX Interface allows a complete integration of air conditioners with KNX Network systems.

- Simple installation due to small and compact size.
- No separate external power supply required (just KNX bus power).
- Can be used for single indoor units and group controlled (up to 16) indoor units

Up to **1** indoor unit

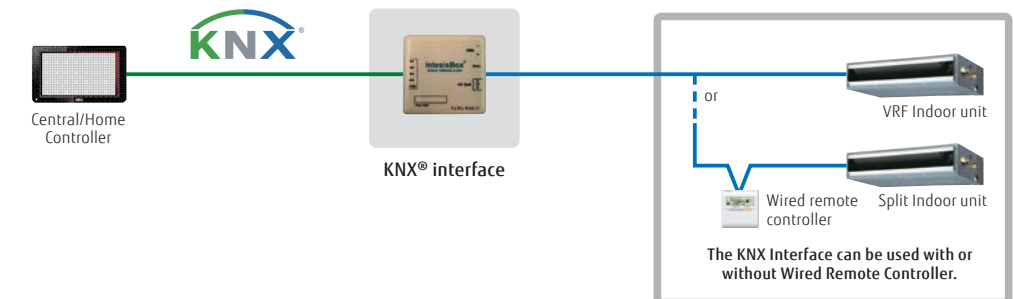

Specifications

Model name	FJ-RC-KNX-1i	
Dimensions (H x W x D)	mm	70 x 70 x 28
Weight	g	70

Wireless LAN Adapter

FJ-RC-WIFI-1



Up to
1 Single indoor unit



- It is the most advanced solution to remotely manage an Air Conditioning system using all sort of mobile devices such as Smartphones, Tablets and PC
- No separate external power supply required
- Can be used for single indoor units and group controlled (up to 16) indoor units

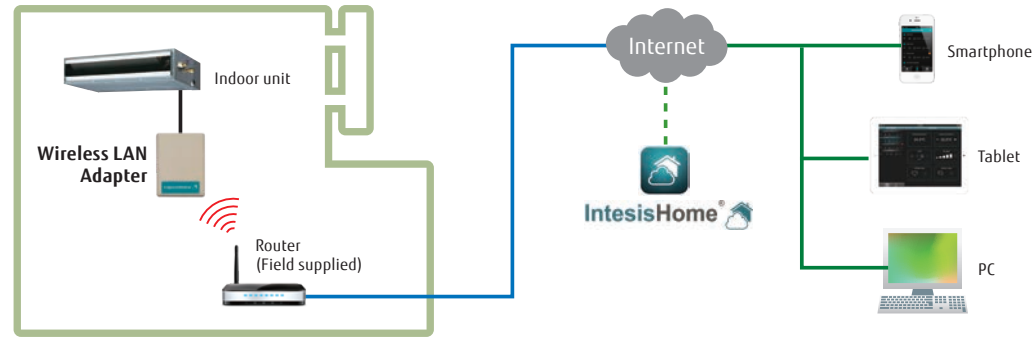

Basic control

- Turning the units on and off
- Mode control (Heat, Cool, Dry, Auto, Fan)
- Fan speed setting
- Louver position (Airflow direction setting)
- Room temperature display
- Set temperature control
- Multi Language
- One Scene and Timer



Notifications and History

- Alerts e-mail notification (future release)
- Air conditioning malfunction alerts
- Connectivity monitoring and alerts
- History (future release)

Advanced control (Optional functions)

- Climate working modes (ECO, Comfort, Powerful) (future release)
- Schedulable functionalities (ON/OFF, Modes, Set point temperature, Fan Speed, Louver position)
- Set temperature limitation (future release)
- Multiple Scenes & Timers and Calendar function

Specifications

Model name	FJ-RC-WIFI-1	
Dimensions (H x W x D)	mm	108 x 70 x 28
Weight	g	80

Network converter

UTY-VTGX / UTY-VTGXV



UTY-VTGX
DC power supply type

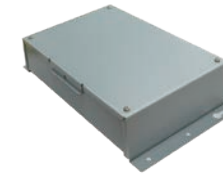

UTY-VTGXV
AC power supply type

Up to
16 single indoor units
Up to
1 group
Up to
100 Network Converters

Compact remote controller provides access to basic functions

- The network converters are required when connecting single split system to VRF network system.
- Compact and light weight design
- Connectable to both types of 2-wire and 3-wire remote controllers

Installation example

- 2 types of 1 remote controller type and 2 remote controllers type are available.
- Power supply (AC220-240V, 50/60Hz) is required for 2 remote controllers type.

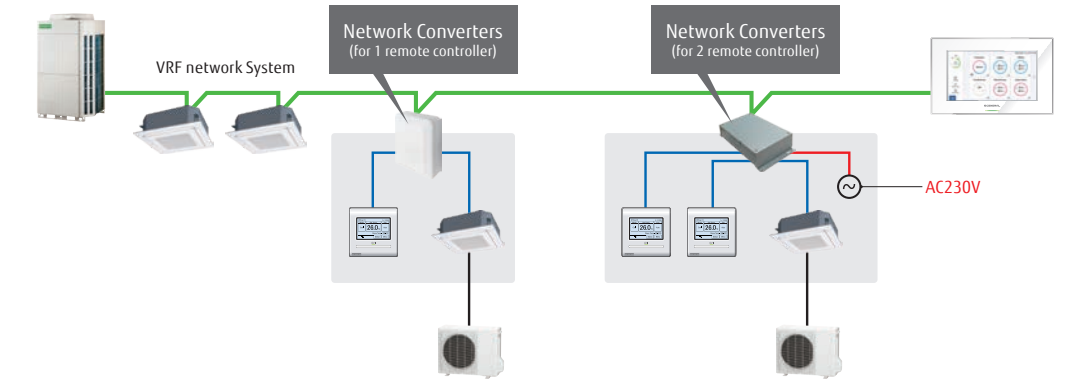

- 2-wire and 3-wire type of the wired remote controller can be connectable.

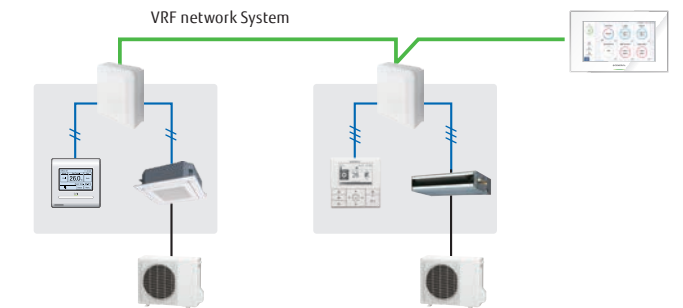

- A central control can be provided for the single split systems. (Up to 100 units of Network Converter is connectable in one VRF network system)

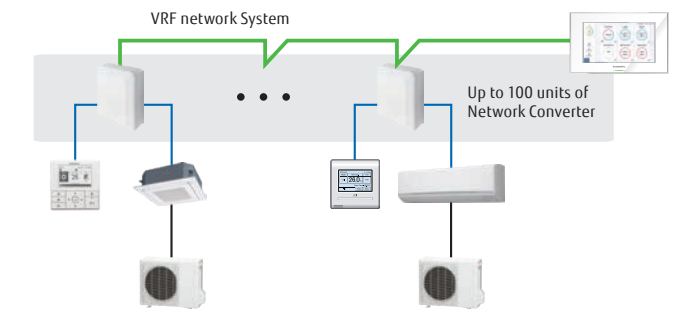

Specifications

Model name	UTY-VTGX		UTY-VTGXV
Power Supply	polar 3-wire DC12V	non-polar 2-wire DC12V	220-240V 50/60Hz, Single phase
Input power	W	Max. 1.2	Max. 3
Dimensions (H x W x D)	mm	140 x 117 x 43	54 x 260 x 150
Weight	g	250	1,100

External switch controller

UTY-TERX



Up to
1 group

- In combination with a field supply Card-Key Switch or other sensor, the External Switch Controller allows control of the ON / OFF, Room temperature, Fan speed and Master control functions. This makes this product suitable for installations such as hotel rooms.
- Card-key or other sensor switches are available as a locally purchased parts.
- The set temperature can be specified at two points for cooling and heating individually (4 points).

Installation example

Human sensor catches movements of people in a room, and operates with lower capacity when people come back to the room, it automatically returns to previous operation mode.

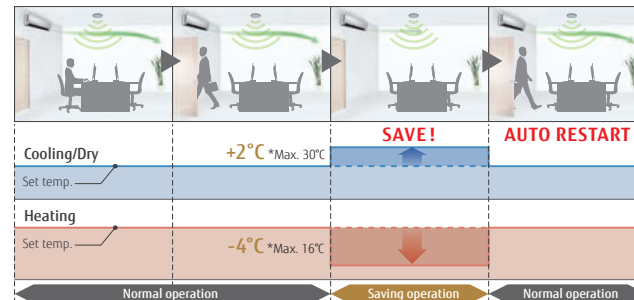

Human sensor equipment needs to be purchased locally. The above example indicated that a signal is sent to this External Switch Controller if human sensor does not detect for 20 minutes. Human sensor is not mounted on the External Switch Controller.

Specifications

Model name	UTY-TERX	
Power Supply	DC 6.5-16V	
Dimensions (H x W x D)	mm	140 x 117 x 43
Weight	g	250

DC12V is supplied by indoor unit.

Signal amplifier

UTY-VSGXZ1

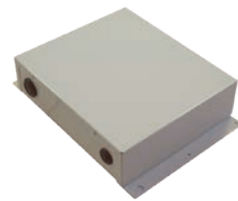

- Transmission Line length can be extended up to 3,600m with multiple Signal Amplifiers.
- Up to 40 signal amplifiers can be installed in a VRF network system.
- A signal amplifier is required,
 - (1) When the total wiring length of the transmission line exceeds 500m.
 - (2) When the total number of units on the transmission line exceeds 64.

Installation example

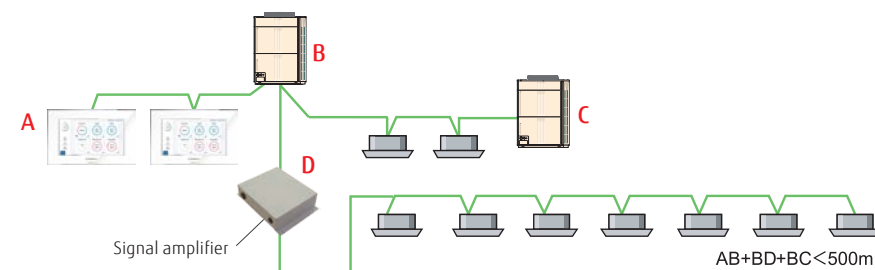

Specifications

Model name	UTY-VSGXZ1	
Power Supply	208-240V 50/60Hz, Single phase	
Input power	W	4.5
Dimensions (H x W x D)	mm	67 x 288 x 211
Weight	g	1,500

Thermostat Converter

UTY-TTRXZ1

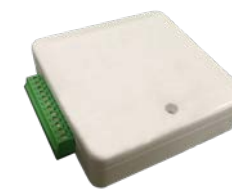

Up to
16 indoor unit

Control air conditioner using third party thermostat

- Thermostat converter can control Fujitsu General products using a third party thermostat. Up to 16 indoor unit can be connected with one thermostat converter.

Installation example

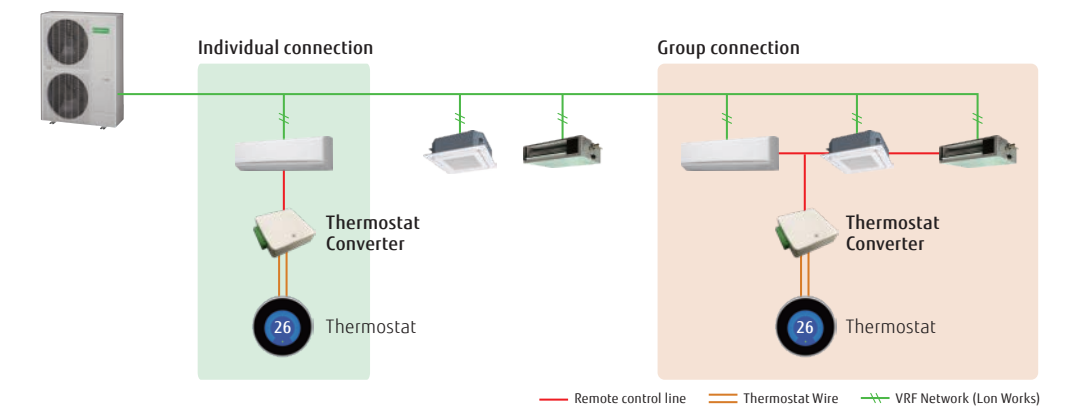

Function

Air Conditioning Control	ON/OFF
	Operation mode
	Room Temperature
	Fan Speed
	Delay OFF

Air Conditioning Control	Indoor unit Error notification*
	Converter Error notification*

*These function are displayed on the converter's PCB board.

Specifications

Model name	UTY-TTRXZ1	
Max. Connectable Indoor Unit	16	
Input power (Max.)	W	0.6
Dimensions (H x W x D)	mm	27 x 86.7 x 86.7
Weight	g	220

VENTILATION

Outdoor-air Processing Unit range

Airflow rate (m ³ /h)	1080	1680	2100
Model code	054	072	096
Outdoor-air Processing Unit	 ARXH054GTAH	 ARXH072GTAH	 ARXH096GTAH

DX Kit
for Air Handling Unit or Fresh Air Handling Unit application

Effective heat exchange and simultaneous fresh air ventilation

High Efficiency and low noise levels are achieved by using a highly efficient heat exchange process. A comfortable air conditioned space is achieved by conveniently selecting whether to use heat exchange or normal ventilation setting, according to the requirements of the conditioned space.

Outdoor-air Processing Unit



One VRF system can provide air conditioning and air supply at the same time.

Outdoor-air Processing Unit can be connected in a same VRF*1 system as one of indoor unit series and can create fresh and comfortable air supply together from our high advanced technology.

*1. Connectable VRF Series: J-IIS

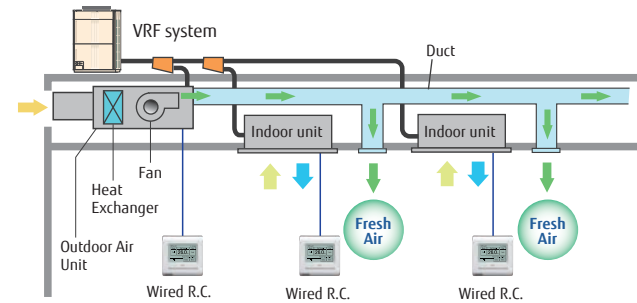
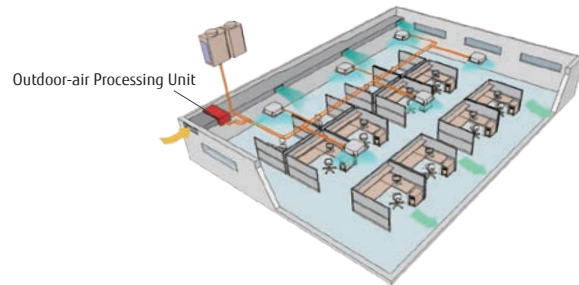

* Make sure the connected capacity is within the range of 50% to 100% of the outdoor unit capacity. In addition, if there are mixed connections with indoor units, make the Outdoor-air Processing Unit connection capacity 30% or less of the outdoor unit capacity.

High energy savings and flexible duct design by using DC motor

- Greatly reduces electricity consumption by adopting permanent magnet compared to when using an AC motor.
- Compared with AC motor, changing the speed makes it possible to respond flexibly to the external static pressure from 50 Pa to 240 Pa. Even if damper equipment is not used, static pressure can be adjusted and duct design is easy.
- Static pressure can be set easily using wired remote controller.

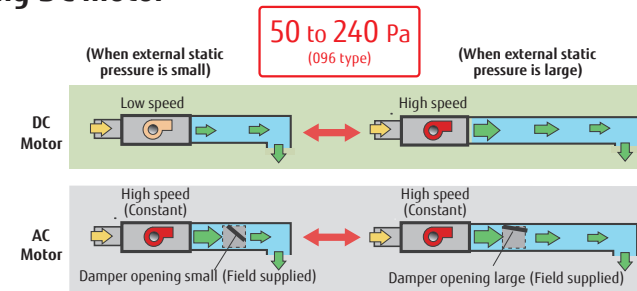

Top class compact design

- Top class lightweight compact design at just 425 mm in height, 55 kg in weight for ARXH072 type. This unit can be installed easily even at narrow space.

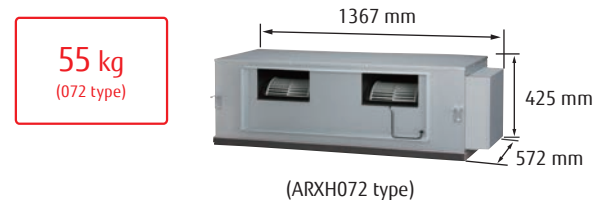

Various Controller

Supplied variety of controllers as options, such as individual controller, central controller, and building management controller.

Individual Controller



Central Controller

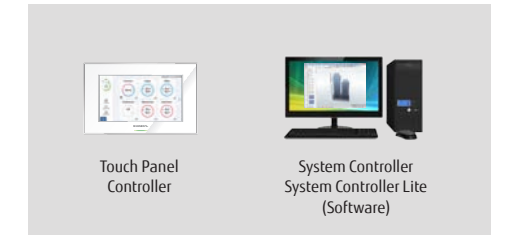

* The temperature setting is discharged air temperature setting. The air volume is set to a constant speed.

Model:
ARXH054GTAH / ARXH072GTAH / ARXH096GTAH



Specifications

Rated flow rate	1000 m ³ /h		1500 m ³ /h		2000 m ³ /h	
Model name	ARXH054GTAH		ARXH072GTAH		ARXH096GTAH	
Power source	V/Ø/Hz		220-240V, 50Hz			
Capacity	Cooling	kW	14.0	22.4	28.0	
	Heating	kW	8.9	13.9	17.4	
Input power	Cooling	W	179	292	370	
	Heating	W	179	292	370	
Airflow rate	m ³ /h		1,080	1,680	2,100	
Static Pressure	Standard (range)	Pa	185 (50-185)	200 (50-200)	200 (50-240)	
Sound Pressure Level	dB(A)		42	44	47	
Dimensions (H × W × D)	mm		425 × 1,367 × 572	425 × 1,367 × 572	450 × 1,583 × 700	
Weight	kg		48	55	71	
Connection pipe diameter	Small	mm	9.52	12.70	12.70	
	Large	mm	19.05	22.22	22.22	
Operating range	Cooling	°CDB	5 to 43	5 to 43	5 to 43	
	Heating	°CDB	-7 to 21	-7 to 21	-7 to 21	
Refrigerant			R410A	R410A	R410A	

Note: Specifications are based on the following conditions.
Cooling: Outdoor temperature of 33°CDB / 28°CWB.
Heating: Outdoor temperature of 0°CDB / -2.9°CWB.
Pipe length: 7.5 m Voltage: 230 [V].

Dimensions (Unit: mm)

Model: ARXH054

Model: ARXH072

Model: ARXH096

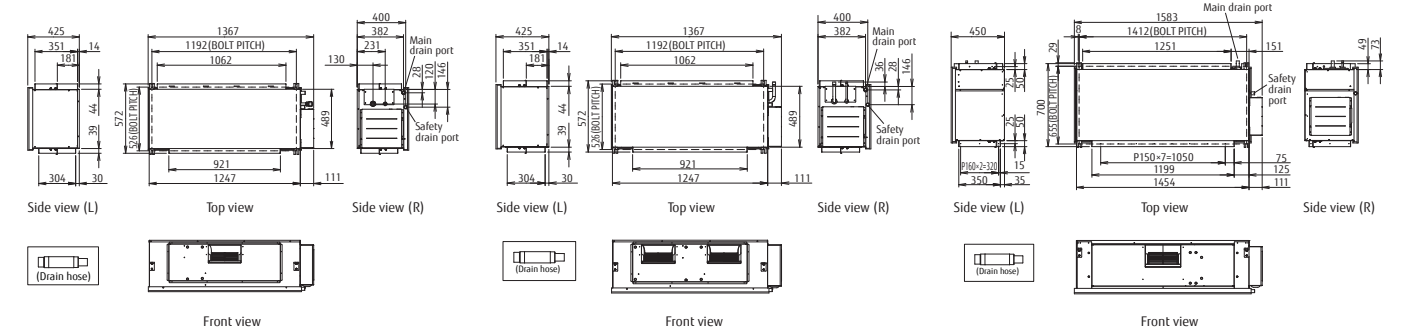

DX kit for Air handling applications for VRF Outdoor unit



Multiple temperature sensors optimally control the air handling unit and fan coil unit.

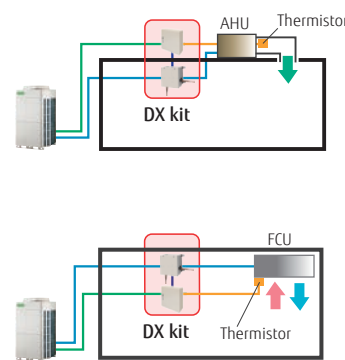

When connected to an Air handling unit, the temperature of supply air is controlled by a discharge air sensor.

When connected to a fan coil unit, the room temperature is controlled by the discharge air sensor.

Application as part of a VRF system

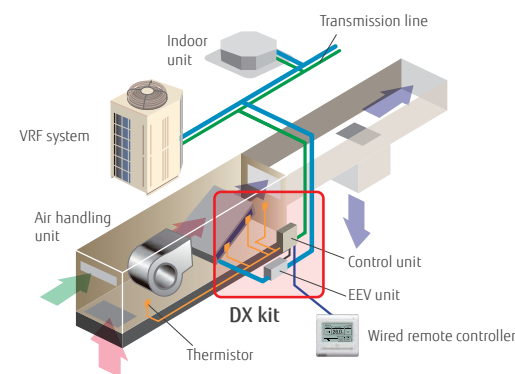

Supports a wide range of capacity classes

- Two EEV units can be connected in parallel to large-capacity units of up to 20 HP (50 kW). (UTP-LX180A separation tube required)
- Connectable capacity range: 5 kW to 50 kW

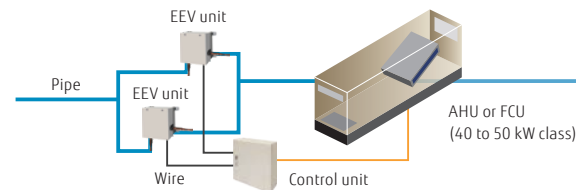

A variety of controls to match the application

- Central control using our VRF controllers or central management controllers

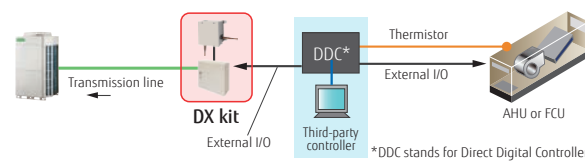
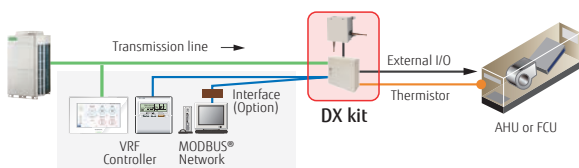

Summary of functions

Inputs

- ON/OFF
- Setting temperature
- Capacity demand
- Heating / Cooling operation mode
- Fault information

Outputs

- ON/OFF indication
- Fan ON/OFF indication
- Thermo ON/OFF indication
- Defrost indication
- Fault indication

Modbus Control

- Possible to control via a Modbus enabled BMS by using optional interface.

Installation requirements

- Connectable VRF Series : All VRF
- Connectable DX Kit system capacity range : 50 to 100 % of the outdoor unit capacity
- Connectable DX Kit system capacity range with indoor units : 30 % or less of the outdoor unit capacity
- Max. wiring length from control unit : 10 m
- Max. piping length between EEV unit and indoor unit : 5 m
- Outdoor installation : Control unit (IP54 class) and EEV unit can be installed at an outdoor space.

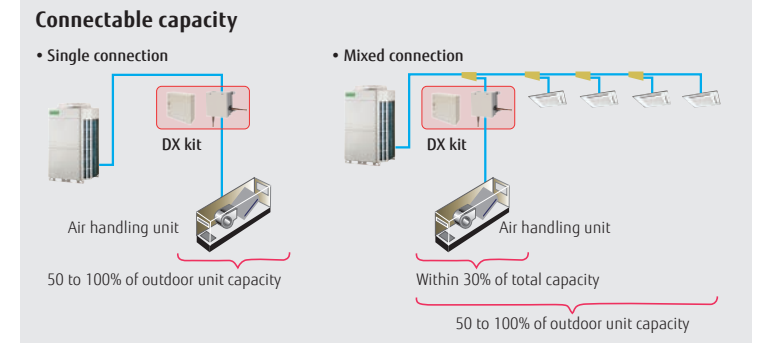

[For 2EEV units connection (option)]

- Separation Tube : UTP-LX180A



Pipe and wire length

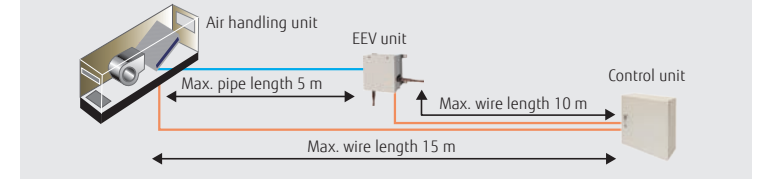

Control unit: UTY-VDGX
EEV unit: UTP-VX30A/UTP-VX60A/UTP-VX90A

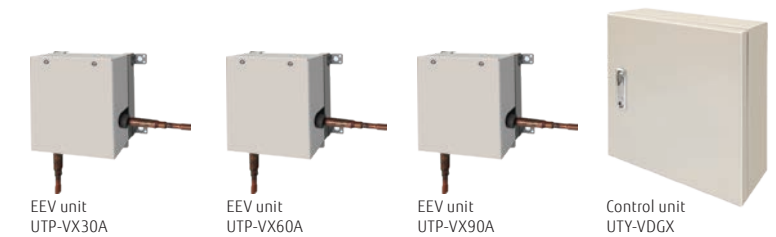

Specifications

EEV unit		UTP-VX30A				UTP-VX60A			UTP-VX90A		UTP-VX90A*2	
Power source	V/Ø/Hz	230/1/50										
Connectable capacity class	kW	5.0	6.3	8.0	10.0	12.5	14.0	20.0	25.0	40.0	50.0	
Capacity	Cooling	5.6 (5.1-5.9)	6.3 (6.0-7.1)	8.0 (7.2-9.0)	10.0 (9.1-11.1)	12.5 (11.2-13.2)	14.0 (13.3-18.0)	22.4 (18.1-23.7)	25.0 (23.8-28.0)	40.0 (28.1-44.7)	50.4 (44.8-50.4)	
	Heating	6.3 (5.7-6.7)	7.1 (6.8-8.0)	9.0 (8.1-10.0)	11.2 (10.1-12.4)	14.0 (12.5-15.0)	16.0 (15.1-20.0)	25.0 (20.1-26.5)	28.0 (26.6-31.5)	45.0 (31.6-49.9)	56.5 (50.0-56.5)	
Airflow Rate(Reference value)	m ³ /h	1,060	1,200	1,520	1,600	2,000	2,240	3,560	4,000	6,400	8,000	
Dimensions (H × W × D)	mm	160 × 220 × 90										
Weight	kg	2										
Connection pipe diameter	Liquid mm	9.52	9.52	9.52	9.52	9.52	9.52	12.70	12.70	12.70	12.70	

Control unit		UTY-VDGX	
Power source	V/Ø/Hz	230 / 1 / 50	
Dimensions (H × W × D)	mm	400 × 400 × 120	
Weight	kg	10	

Note : Specifications are based on the following conditions.
Cooling : Indoor temperature of 27°CDB / 19°CWB, and outdoor temperature of 35°CDB / 24°CWB.
Heating : Indoor temperature of 20°CDB / (15°CWB), and outdoor temperature of 7°CDB / 6°CWB.
Pipe length : 7.5 m Voltage : 230 [V].

VRF OPTION

Pressure Sensor Kit
Auto Louver Grille Kit
CONTROL SYSTEM LIST
OPTIONAL PARTS LIST
OPTIONAL PARTS
FUNCTION LIST
SEPARATION TUBE etc.

Diverse building air conditioning control functions can be controlled easily by VRF options.

Various kinds of optional parts are provided such as controllers, adaptors and converters to meet the needs of every user.

Pressure sensor kit

UTY-SPWX



Design Flexibility

The height difference between the outdoor unit and the indoor unit is usually 50 m for the V-III Series, but by installing the pressure sensor kit it is possible to expand it to 110 m. (*This product can be used connected only V-III series. Also, it is possible to use only the outdoor unit that outdoor unit software is compatible with this product. The software for outdoor unit will be changed since production lot in January 2018.)

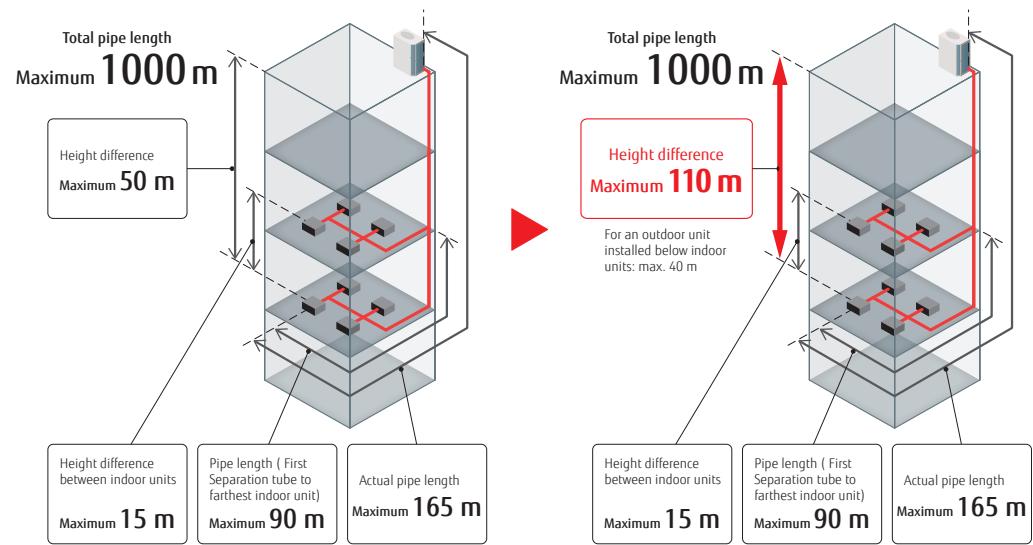

System overview

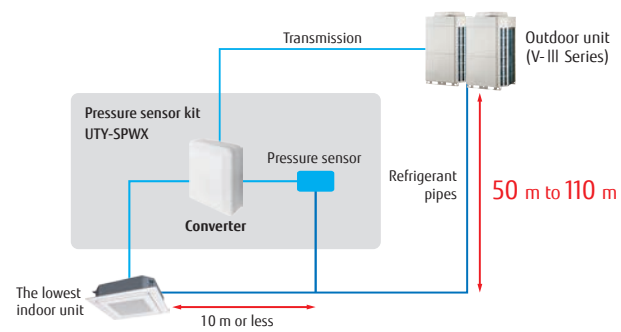

Pressure sensor kit

Pressure sensor kit (Converter)	Refrigerant pressure sensor	Joint pipe

Specifications

Model name	UTY-SPWX	
Power Supply	DC16-9	
Dimensions (H x W x D)	mm	140 x 117 x 43
Weight	g	200

Auto louver grille kit

UTD-GXTA-W / UTD-GXTB-W / UTD-GXTC-W



The optional clean-looking flat Auto louver grille kit blends into any interior and provides a comfortable airflow.



Flexible Control

- Operation with indoor unit
Auto Louver can be operated by synchronizing remote controller of indoor unit.
- UP and Down auto swing
- Auto airflow direction and auto swing
- 4 steps selectable
- Auto-closing louver
When operation of indoor unit is stopped, the louver will automatically close.

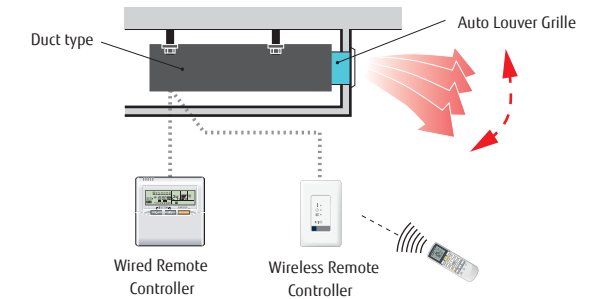

Dimensions

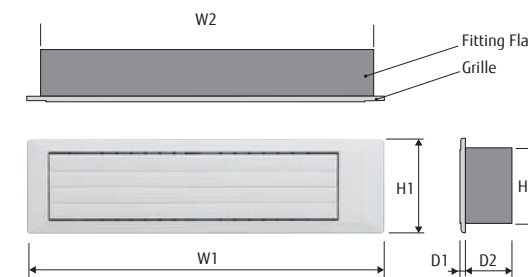

Unit: mm

Model name	W1	W2	H1	H2	D1	D2
UTD-GXTA-W	683	645	180	148	9	84
UTD-GXTB-W	883	845	180	148	9	84
UTD-GXTC-W	1,083	1,045	180	148	9	84

Specifications

Model name	UTD-GXTA-W	UTD-GXTB-W	UTD-GXTC-W
Applicable Indoor Unit	ARXD07/09/12/14GATH	ARXD18GATH	ARXD24GATH
Power source	Connecting with Control box of indoor unit		
Fixing of Auto Louver Grille	Screw fixing to Flange or Square Duct		
Extension Square Duct Limit	1.0m (Max. duct length between indoor unit and Grille)		
Dimensions (H x W x D)	mm	180 x 683 x (84+9)	180 x 883 x (84+9)
Weight	Net	kg	2.0
	Gross	kg	3.0
Color	White		
Louver Motor	Stepping Motor		
Accessories	Fitting Flame, etc.		
Operating range	Cooling	°C	18 to 32
		% RH	80% or less
	Heating	°C	16 to 30

*: The Auto Louver Grille Kit can also be installed to ARGD07/09/12/14/18/24GATH revision code B models. Please refer to the Design & Technical manual for "revision code" details.













CONTROL SYSTEM LIST

Controllers / Interface

Type	Indoor unit												
	Cassette			Duct		Duct		Indoor unit		Wall Mounted			
	4-way Compact	Circular Flow		Slim (With drain pump)	Medium Static Pressure	High Static Pressure		Ceiling / Floor	Ceiling	-	-		
AUXB 09/12/14/18/24 GATH	AUXM018/024GTAH	AUXK 018/024/030/034/ 036/045/054 GTAH	ARXD 07/09/12/14/18/24 GATH	ARXA 24/30/36/45 GBTH	ARXC36/72/90GBTH, ARXC96GATH	ARXC45/60GATH	ABHA 12/14/18/24 GATH	ABHA 30/36/45/54 GATH	ASHA 07/09/12/14 GATH	ASHA 18/24/30 GATH			
Controllers	Wired Remote Controller	● UTY-RNRGZ5							● UTY-RNRGZ5				
		● UTY-RLRG							● UTY-RLRG				
	Compact Wired Remote Controller	● UTY-RCRGZ1, UTY-RCRGZ1K							● UTY-RCRGZ1, UTY-RCRGZ1K				
	Simple Remote Controller	● UTY-RSRG, UTY-RHRG, UTY-RSKG, UTY-RHKG							● UTY-RSRG, UTY-RHRG, UTY-RSKG, UTY-RHKG				
	Wireless Remote Controller	● UTY-LNHG							● UTY-LNHG				
	Central Remote Controller	● UTY-DCGGZ3							● UTY-DCGGZ3				
	System Controller, System Controller Lite	● UTY-APGXZ1, UTY-ALGXZ1							● UTY-APGXZ1, UTY-ALGXZ1				
Interface	IR Receiver Unit		● UTY-LBHxD		● UTB-YWC		● UTB-YWC						
	BACnet Gateway	● UTY-ABGXZ1, UTY-VBGX							● UTY-ABGXZ1, UTY-VBGX				
	Network Converter for LonWorks	● UTY-VLGX							● UTY-VLGX				
	MODBUS Converter	● UTY-VMGX							● UTY-VMGX				
	MODBUS Interface	● FJ-RC-MBS-1			● FJ-RC-MBS-1		● FJ-RC-MBS-1 (ARXC45/60GATH, ARXC96GATH only)			● FJ-RC-MBS-1			
	KNX Converter	● UTY-VKGX							● UTY-VKGX				
	KNX Interface	● FJ-RC-KNX-1i			● FJ-RC-KNX-1i		● FJ-RC-KNX-1i (ARXC45/60GATH, ARXC96GATH only)			● FJ-RC-KNX-1i			
	Wireless LAN Interface	● FJ-RC-WIFI-1			● FJ-RC-WIFI-1		● FJ-RC-WIFI-1 (ARXC45/60GATH, ARXC96GATH only)			● FJ-RC-WIFI-1			
	External Switch Controller	● UTY-TERX							● UTY-TERX				
	Network Converter for single split	DC Power Supply Type	AC Power Supply Type	● UTY-VTGX, UTY-VTGXV						● UTY-VTGX, UTY-VTGXV			
	Thermostat Converter	● UTY-TTRXZ1							● UTY-TTRXZ1				

OPTIONAL PARTS LIST











Others

Type	Indoor unit											Outdoor unit
	Cassette			Duct		Duct		Indoor unit		Wall Mounted		
	4-way Compact	Circular Flow		Slim (With drain pump)	Medium Static Pressure	High Static Pressure		Ceiling / Floor	Ceiling	-	-	
AUXB 09/12/14/18/24 GATH	AUXM018/024GTAH	AUXK 018/024/030/034/ 036/045/054 GTAH	ARXD 07/09/12/14/18/24 GATH	ARXA 24/30/36/45 GBTH	ARXC36/72/90GBTH, ARXC96GATH	ARXC 45/60GATH	ABHA 12/14/18/24 GATH	ABHA 30/36/45/54 GATH	ASHA 07/09/12/14 GATH	ASHA 18/24/30 GATH	AJS 072/090/ 108/126/144 LNTCH	
Human Sensor Kit		● UTY-SHZXC										
Remote Sensor Unit	 <small>New amenity space can be offered by installing the Remote sensor.</small>			● UTY-XSZX		● UTZ-PX1NBA						
Cassette Grille	 UTG-UFGC-W UTG-UKGD-W UTG-UKGA-B	● UTG-UFGC-W	● UTG-UKGD-W UTG-UKGA-B									
Auto Louver Grille Kit				● UTD-GXTA-W UTD-GXTB-W(18) UTD-GXTC-W(24)								
Long Life Filter					● UTD-LF25NA	● UTD-LF60KA(36/45/60)						
Flange					● UTD-SF045T UTD-RF204			● UTD-RF204				
Drain Pump Unit					● UTZ-PX1NBA			● UTR-DPB24T				
Wide Panel	 <small>Indoor unit 950 Panel 600 (mm)</small>		● UTG-AKXA-W									
Panel Spacer	 <small>(mm) 2x2 Panel spacer</small>		● UTG-BKXA-W									
Air Outlet Shutter Plate	 For Compact Cassette For Cassette	● UTR-YDZB	● UTR-YDZK									
Insulation for High Humidity	 For Compact Cassette type / Cassette type	● UTZ-KXGC	● UTZ-KXRA									
Pressure Sensor Kit for V-III Series*												● UTY-SPWX

OPTIONAL PARTS

Controllers

For Individual Control













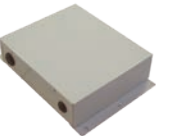

<p>Wired Remote Controller (Touch Panel) UTY-RNRGZ5</p> 	<p>Wired Remote Controller UTY-RLRG</p> 	<p>Compact Wired Remote Controller UTY-RCRGZ1</p> 
<p>Compact Wired Remote Controller UTY-RCRGZ1K</p> 	<p>Simple Remote Controller UTY-RSRG With operation mode</p> 	<p>Simple Remote Controller UTY-RHRG Without operation mode</p> 
<p>Wireless Remote Controller UTY-LNHG</p> 	<p>IR Receiver Unit UTB-YWC For All Duct types except Large Airflow Duct</p> 	<p>IR Receiver Unit UTY-LBHxD For Circular Flow Cassette type</p> 
<p>Human Sensor Kit UTY-SHZXC For Circular Flow Cassette type</p> 		

For Centralized Control

<p>Central Remote Controller NEW UTY-DCGGZ3</p> 	<p>System Controller Lite Software UTY-ALGXZ1 WHITE-USB-KEY (Software Protection Key) Option UTY-PLGXR2 UTY-PLGXA2 UTY-PLGXE2 UTY-PLGXX2</p> 	<p>System Controller Software UTY-APGXZ1 WHITE-USB-KEY (Software Protection Key) Option UTY-PEGXZ1</p> 
---	---	---

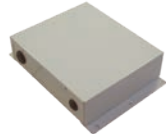
Converters / Adaptors

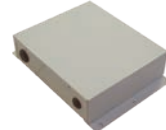
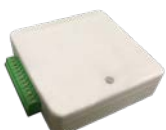
For External device / System expansion

<p>BACnet® Gateway Software UTY-ABGXZ1 WHITE-USB-KEY (Software Protection Key)</p> 	<p>BACnet® Gateway Hardware UTY-VBGX</p> 	<p>Network Converter for LONWORKS® UTY-VLGX</p> 
<p>MODBUS® Converter Hardware for VRF UTY-VMGX</p> 	<p>MODBUS® Interface FJ-RC-MBS-1</p> 	<p>KNX® Converter for VRF Hardware UTY-VKGX</p> 
<p>KNX® Interface FJ-RC-KNX-1i</p> 	<p>Wireless LAN Interface FJ-RC-WIFI-1</p> 	<p>Network Converter for single split UTY-VTGX DC power supply type</p> 
<p>Network Converter for single split UTY-VTGXV AC power supply type</p> 	<p>Network Converter for Group Remote Controller UTY-VGGXZ1</p> 	<p>External Switch Controller UTY-TERX</p> 
<p>Signal Amplifier UTY-VSGXZ1</p> 	<p>Thermostat Converter UTY-TTRXZ1</p> 	<p>Pressure Sensor Kit for V-III tropical Series* UTY-SPWX</p> 

OPTIONAL PARTS



Panels

For Cassette type

<p>Cassette Grille UTG-UFGD-W For Compact Cassette type</p> 	<p>Cassette Grille UTG-UKGD-W For Circular Flow Cassette type</p> 	<p>Cassette Grille UTG-UKGA-B For Circular Flow Cassette type</p> 
--	--	--

Others

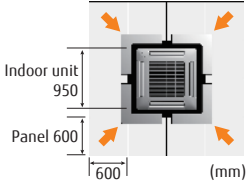
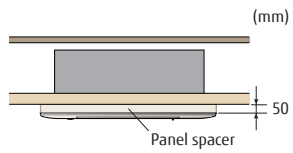
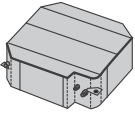
For Cassette type







<p>Wide Panel UTG-AKXA-W For Cassette type</p> 	<p>Panel Spacer UTG-BGYA-W For Cassette type</p> 	<p>Insulation Kit for High Humidity UTZ-KXRA For Cassette type UTZ-KXGC For Compact Cassette type</p> 
<p>Air Outlet Shutter Plate UTR-YDZB For Compact Cassette type Shuts the air outlet when only using as 3 blow out.</p> 	<p>Air Outlet Shutter Plate UTR-YDZK For Cassette type Shuts the air outlet when only using as 3 blow out.</p> 	

For Ceiling type











<p>Drain Pump Unit UTR-DPB24T For Ceiling type</p> 		
---	--	--

Others

For Duct type

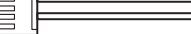
<p>Flange (Round) UTD-RF204 For Medium Static Pressure Duct type / Ceiling type</p> 	<p>Flange (Square) UTD-SF045T For Medium Static Pressure Duct type</p> 	<p>Remote Sensor Unit UTY-XSZX For All Duct type New amenity space can be offered by installing the Remote sensor.</p> 
<p>Long-Life Filter UTD-LF25NA For Medium Static Pressure Duct type UTD-LF60KA For High Static Pressure Duct type</p> 	<p>Auto Louver Grille Kit UTD-GXTA-W (for ARXD07/09/12/14) UTD-GXTB-W (for ARXD18) UTD-GXTC-W (for ARXD24) For Slim Duct type</p> 	<p>Drain Pump Unit UTZ-PX1NBA For Medium Static Pressure Duct</p> 

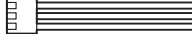
Communication system: External Connect Kit

<p>For Indoor unit</p> <p>UTY-XWZXZ7 </p> <p>UTY-XWZXZB </p> <p>UTY-XWZXZC </p>	<p>UTY-XWZXZD </p> <p>UTY-XWZXZE </p>	<p>For Outdoor unit</p> <p>UTY-XWZXZ6 </p> <p>UTY-XWZXZ9 </p> <p>UTY-XWZXZF </p>
<p>For Central Remote Controller</p> <p>UTY-XWZXZ7 </p> <p>UTY-XWZXZ8 </p> <p>UTY-XWZXZA </p>	<p>For Touch Panel Controller</p> <p>UTY-XWZXZA </p>	

FUNCTION LIST









Type	Indoor unit												Outdoor unit		Controller	
	Cassette			Duct				Ceiling / Floor	Indoor unit		Wall Mounted		J-III Tropical	V-III Tropical	Central Remote Controller	
	4-way Compact	Circular Flow		Slim (With drain pump)	Medium Static Pressure	High Static Pressure	High Static Pressure		Ceiling	-	-					
AUXB 09/12/14/18/24 GATH	AUXM 018/024GTAH	AUXK 018/024/030/034/ 036/045/054 GTAH	ARXD 07/09/12/14/18/24 GATH	ARXA 24/30/36/45 GBTH	ARXC36/72/90GBTH, ARXC96GATH	ARKC45/60GATH	ABHA 12/14/18/24 GATH	ABHA 30/36/45/54 GATH	ASHA 07/09/12/14 GATH	ASHA 18/24/30 GATH	AJH 040/045/054 LBTAHN, AJH 040/045/054 LETAHN	AJS 072/090/ 108/126/144 LNTCH	UTY-DCGG22			
Indoor	Operation / Stop	●UTY-XWZXZD ○UTY-XWZXZB						●UTY-XWZXZD ○UTY-XWZXZB								
	All On / All Off														●UTY-XWZXZ7 ○UTY-XWZXZ8	
	Group Stop													●UTY-XWZXZ6		
	Forced Stop	●UTY-XWZXZD ○UTY-XWZXZB						●UTY-XWZXZD ○UTY-XWZXZB								
	Emergency Stop	●UTY-XWZXZD ○UTY-XWZXZB						●UTY-XWZXZD ○UTY-XWZXZB							●UTY-XWZXZ6	●UTY-XWZXZ7 ○UTY-XWZXZ8
	Forced Thermostat off	●UTY-XWZXZE ○UTY-XWZXZ7						●UTY-XWZXZE ○UTY-XWZXZ7								
	Low Noise Mode Operation													●UTY-XWZXZ6		
	Cooling/ Heating Priority															
	Outdoor Unit Operation Peak Control													●UTY-XWZXZ6		
	Power Usage Information from Electricity Meter													●UTY-XWZXZF		
Output	Operation Status	●UTY-XWZXZC						●UTY-XWZXZC							○UTY-XWZXZ6	○UTY-XWZXZA
	Error Status	●UTY-XWZXZC						●UTY-XWZXZC							○UTY-XWZXZ6	○UTY-XWZXZA
	Indoor Unit Fun Operation Status	●UTY-XWZXZC						●UTY-XWZXZC								
	Auxiliary Heater Output				●UTY-XWZXZC											
	Base Heater													●UTY-XWZXZ9		

●: Dry Contact ○: Apply Voltage





SEPARATION TUBE etc.

Connection Units



Separation Tube

<p>UTP-AX054A</p> <p>Gas Pipe </p> <p>Liquid Pipe </p>	<p>UTP-AX090A</p> <p>Gas Pipe </p> <p>Liquid Pipe </p>	<p>UTP-AX180A</p> <p>Gas Pipe </p> <p>Liquid Pipe </p>
<p>UTP-AX567A</p> <p>Gas Pipe </p> <p>Liquid Pipe </p>	<p>UTP-LX180A for DX Kit</p> 	

Header

<p>UTR-H0906L / UTR-H1806L</p> <p>Gas Pipe </p> <p>Liquid Pipe </p>	<p>UTR-H0908L / UTR-H1808L</p> <p>Gas Pipe </p> <p>Liquid Pipe </p>	
---	---	--

Outdoor Unit Branch Kit

<p>UTP-CX567A</p> <p>Gas Pipe </p> <p>Liquid Pipe </p>		
--	--	--

Specifications

Separation Tube

Model name		UTP-AX054A	UTP-AX090A	UTP-AX180A	UTP-AX567A
Total cooling capacity of indoor unit	kW	19.6 or less	28.0 or less	28.1 to 56.0	56.1 or more
Model name		UTP-BX090A		UTP-BX180A	UTP-BX567A
Total cooling capacity of indoor unit	kW	28.0 or less		28.1 to 56.0	56.1 or more

Header

Model name		3-6 Branches	UTR-H0906L	UTR-H1806L
		3-8 Branches	UTR-H0908L	UTR-H1808L
Total cooling capacity of indoor unit	kW	28.0 or less		28.1 to 56.0
Model name		3-6 Branches	UTP-J0906A	UTP-J1806A
		3-8 Branches	UTP-J0908A	UTP-J1808A
Total cooling capacity of indoor unit	kW	28.0 or less		28.1 to 56.0

Outdoor unit Branch kit

Model name		UTP-CX567A (for V-III Tropical)	
		2 outdoor units	1
		3 outdoor units	2

Reducer kit

Model name	UTP-NX18A	UTP-NX54A
Applicable Model	AUXK018GTAH AUXM018GTAH AUGK018GTAH AUGM018GTAH	AUXK036/045/054GTAH AUXM036/045/054GTAH

SUPPORT

Our know-how supports you not only during the product release but also from guiding implementation to product maintenance.

Support

HVAC system design support tool

Quick service & maintenance

Service tool

Web monitoring tool

Category	Information Material											Tool				
	Product Sales Training Material	Product Technical Training Material	Product news	Brochures	Feature Promotion Movie	Operating Manual	Design & Technical Manual	Certificate Data	2D CAD Data	3D CAD (Revit) Data	Installation Manual	Service Manual	Design Simulator (Room air conditioner, Packaged air conditioner, VRF)	CFD Simulation	Service Tool / Web Monitoring Tool	Mobile Technician
Product Training	•	•														
Product Information Seek			•	•	•	•	•									
Technical Information Seek						•	•									
Model Selection						•							•			
Design						•		•	•							
Verification														•		
Installation						•				•						
After sales and Service												•			•	•



Support

Fujitsu General provides a variety of product and technical information to engineers and consultants, and also conducts new product research and design support activities. We provide a wide range of support to maintain high quality from design to installation.



Training facilities

Technical information

We provide equipment selection software that facilitates the design of air conditioning systems by providing performance data for the units and estimation for model selection.

Features

- Design & Technical manuals
- Model selection & estimation
- Certification data
- 2D/3D CAD data

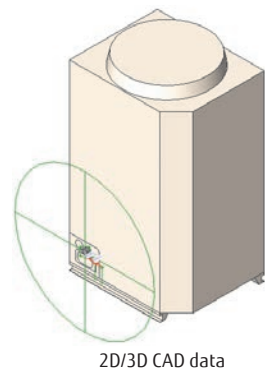

2D/3D CAD data

Technical support

Technical support is offered at every stage, from design through to installation, to assist in optimizing air conditioning solutions.

Features

- CFD simulation
- Guidelines
- Commissioning support

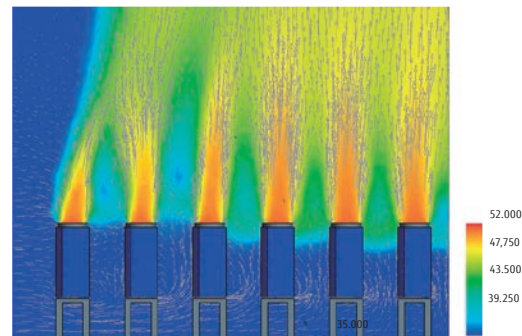

CFD simulation



Commissioning support

Product information

Information on new models is provided in the form of documents and movies in a timely manner for release, readily downloadable from the private section of our website. Contact your Fujitsu General representative for access information.

Features

- Product news
- Brochures & manuals
- Promotional movies

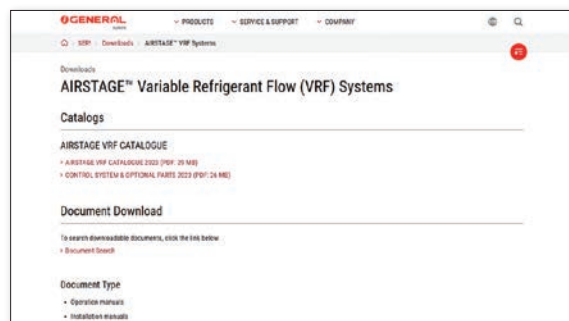

<https://www.fujitsu-general.com/g-eu/support/downloads/vrf/>



Fujitsu General regularly provides professional product, technical and service training at its training facilities worldwide. These research facilities also support the development of human resources with advanced technical skills.

Features

- Designing VRF systems
- On-site training for control systems

- 1 Head office training center in Japan
- 2 Training center in China
- 3 Asia training center in Singapore
- 4 Europe training center in the United Kingdom
- 5 Europe training center in Germany
- 6 America training center in the United States
- 7 Middle East training center in the UAE
- 8 Oceania training center in Australia

HVAC system design support tool

Put the charts and pens away and design your projects on your computer with ease using the Design Simulator. Everything from selecting indoor and outdoor units, allocating controls and optional parts to designing the piping and wiring systems is made easier using the program's built-in features. Once your project is designed take advantage of the Export functions to easily get materials lists, product specifications, refrigerant calculations and more - it'll even export to Word, Excel, or Acrobat formats, and group the relevant CAD data for your project.



Design simulator

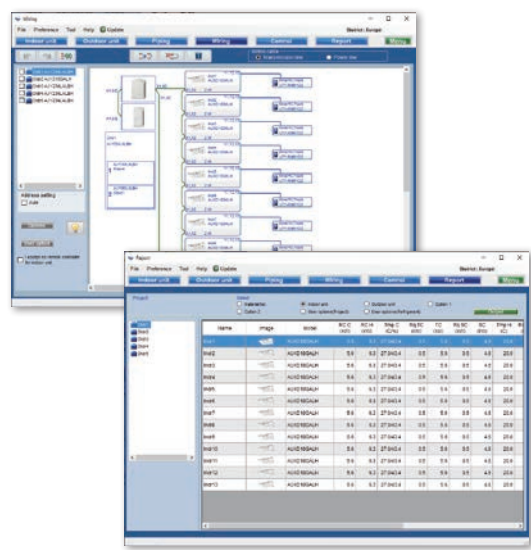

Outputs in the format that matches the application

You can export your project information in a number of industry standard file formats.

- Word format (rtf) (doc)
- Excel format (csv)
- Acrobat format (pdf)
- 2D CAD data (DXF)

Automatically create model selection information

- The required performance, type, and temperature conditions for each indoor unit are entered and then dragged and dropped onto the outdoor unit to automatically set each unit.
- Creates piping and wiring diagrams automatically to facilitate branching, grouping, and option settings.
- The additional refrigerant charging is automatically calculated when the pipe length is entered.
- Easy configuration of remote controller groups, central controller, and converters.
- The equipment list including the equipment information is created automatically.

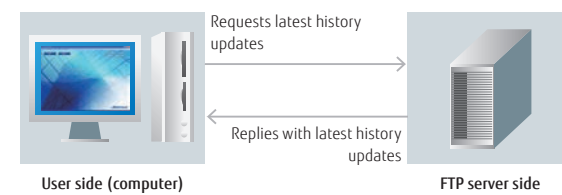

Update your Design simulator

The database can be updated easily online with the AutoUpdate function using FTP.

BIM Building information modeling



BIM files of Fujitsu General's products are available on BIMobject®

Fujitsu General is releasing BIM files of our products on the BIMobject® website BIMobject.com.

Outline of BIMobject®
BIMobject® is a game changer for the construction industry, offering development, maintenance, and syndication of objects on the world's largest BIM platform.

About BIM files

- BIM files can be viewed in Autodesk Revit® 2018 version or later.
- In each BIM file, the location of the connectors for the refrigerant and drain pipe is different.
- Each BIM file includes several family types.
- A catalog and specification sheet is available in Revit file format for each product.

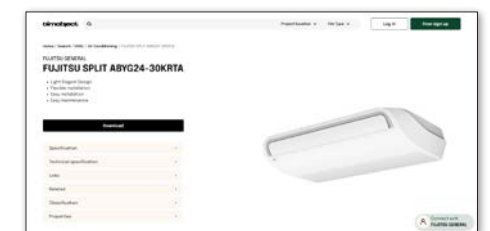
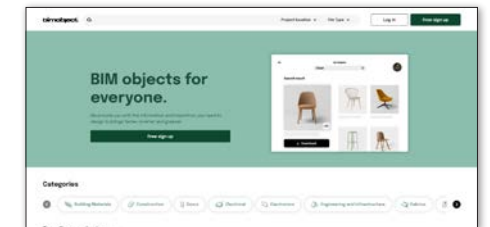

R RFA (Revit data)
A data format available for BIM-designed projects

- Data content**
- Shape (Size)
 - Drain direction
 - Pipe direction
 - Power supply location
 - It contains information about the above specifications.

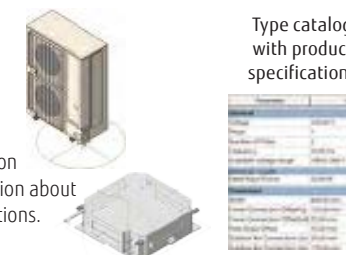

A DWG
a standard data format used for Autodesk products

DXF
Intermediate data commonly available in CAD products



*To learn more about how to use BIM files, refer to the instructional video on each product page. youtu.be/wfL-hwFQ7dM

Quick service & maintenance

If trouble should occur in a unit or system, abundant support tools such as trouble code display at the product, Service Tool that allows checking of the detailed status of the entire system, and remote monitoring tool that uses the internet, etc. support quick service and maintenance anywhere and at any time.



Easy maintenance & monitoring

Designed for easy maintenance

The operating status of the air conditioner and detailed trouble conditions are displayed on the 7-segment indicator lamp on the outdoor unit printed circuit board (PCB) and on the screen of the remote controller.

Check the status of the unit quickly for a prompt response.

- Display the operation mode at the time.
- Discharge temperature and pressure
- Compressor operation status
- "Address/Type/Number" of the outdoor unit
- Error code



Error diagnosis by Service tool

Connect Service tool to check the status details of units, from single split to VRF, on a computer screen.

Check the errors quickly for prompt countermeasures.

- Operating status/control
- Monitoring operating conditions
- Monitoring sensor data
- Indicating trend graphs
- Error history
- Indicating refrigerant circuit diagrams (for VRF)

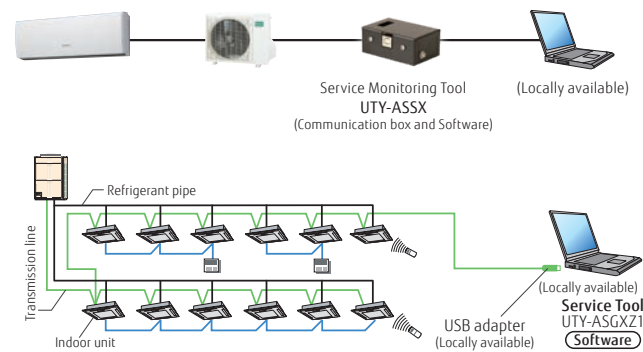

Remote monitoring

VRF system operating status and trouble status details can be monitored remotely at any time via the internet.

Prompt coordination is available with service personnel.

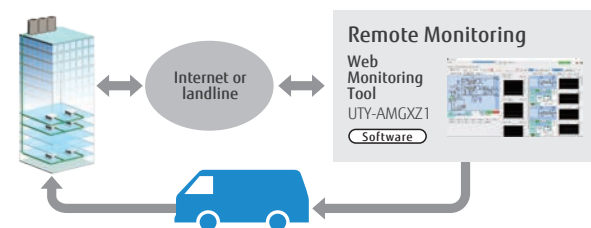

Mobile troubleshooting App for iOS and Android™ devices

We will release an App for troubleshooting tools for iPhone, iPod touch and other Apple devices, and Android products for Fujitsu General air conditioners (Room air conditioner/ Packaged air conditioners VRF and ATW, "AIRSTAGE Mobile", and R32 calculation of allowable refrigerant capacity)

Use Error Code Check, Troubleshooting, and Sensor Check to understand the status of your air conditioner.

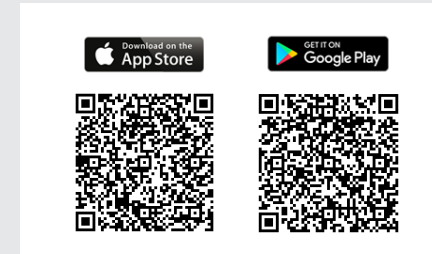

Service monitoring tool for Single split, Multi-split & Air to water



- A quick overview of the temperature sensor readings and the electronic expansion valves (EEVs), fans, compressors and other control components
- It is not always easy to read the temperature sensor and know the status of the control components. So let the Service monitoring tool judge them.
- Visualizes protected operations
- Troubleshoots intermittent problems effectively
- Provides proof of normal operation to customers during periodical maintenance

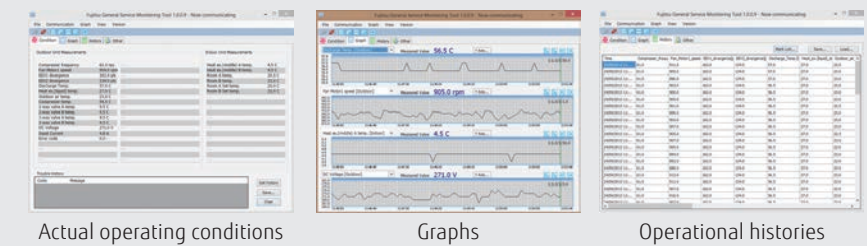

Dimensions (H × W × D) (mm)	60 × 160 × 160
Weight (g)	500

Service tool

UTY-ASGXZ1

Extensive monitoring and analysis functions that make installation and maintenance easier

- The operation status of the system can be monitored and analyzed to detect any malfunctions.
- Data on the operation status of the system can be stored on a computer to allow for remote access.
- Up to 400 indoor units in a single VRF network system can be controlled and monitored for a large building or hotel.
- This software can be connected to any point of transmission line with a USB adapter (locally available).

* Saved data can be displayed offline. Note that the data saved by the following software applications cannot be displayed.

- UTR-YSTB/UTR-YSTC (Service tool)
- UTR-YMSA (Web monitoring tool)

Automatic operation check for refrigeration cycles

Once installed, the Service tool automatically checks for refrigeration cycles. The self-diagnosis function determines whether each sensor value is normal, which reduces the need for manual checks. The result of a diagnosis can be provided in a report.

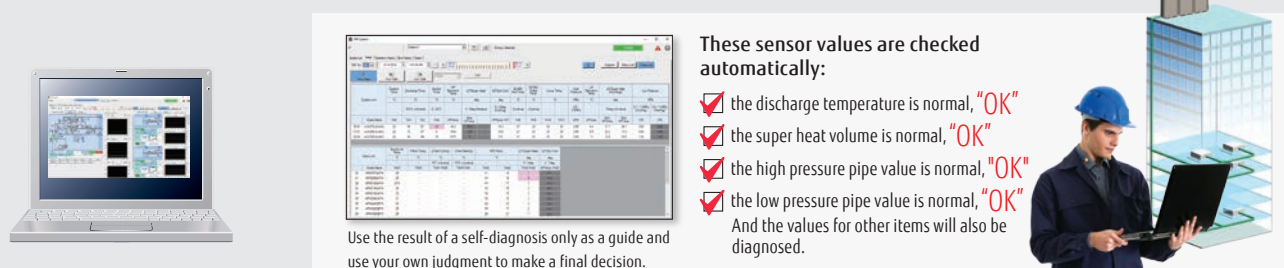

These sensor values are checked automatically:

- ✓ the discharge temperature is normal, "OK"
- ✓ the super heat volume is normal, "OK"
- ✓ the high pressure pipe value is normal, "OK"
- ✓ the low pressure pipe value is normal, "OK"

And the values for other items will also be diagnosed.

Use the result of a self-diagnosis only as a guide and use your own judgment to make a final decision.

Remote technical support and maintenance

On-site check screen can be shared between on-site staff and a service technician in a remote location. When a service technician visits the site for troubleshooting, the system's operation status can be shared in real time with a remote service center for assistance. On-site staff can have an online chat with a remote service center to get further assistance.

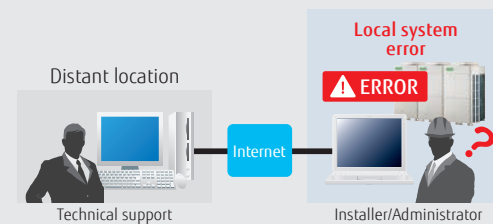

Trend charts

Previous-generation application could display only 3 sets of data from sensors. However, the current generation of the service tool displays multiple charts simultaneously so that refrigeration cycles can be monitored and checked in greater detail.



Computer requirements

UTY-ASGXZ1	
Operating system	• Microsoft® Windows® 7 Professional (32-bit or 64-bit) SP1 • Microsoft® Windows® 8.1 Pro (32-bit or 64-bit) • Microsoft® Windows® 10 Pro (32-bit or 64-bit)
CPU	1 GHz or higher
Memory	• 1 GB or more (for Windows® 7 [32-bit], Windows® 8.1 [32-bit], and Windows® 10 [32-bit]) • 2 GB or more (for Windows® 7 [64-bit], Windows® 8.1 [64-bit], and Windows® 10 [64-bit])
HDD	40 GB or more of free space
Screen resolution	1366 × 768 pixels or higher
Interface	• USB port for U10 USB Network interface and software protection key
Software	Internet Explorer® 11 or Microsoft Edge

Packing list

Name	Quantity	Application
White-USB-key (Software protection key)	1	Software protection key to be connected to a USB port on a Service tool-installed computer. This software runs only on a computer with WibuKey.

- Computer requirements
- Echelon® U10 USB Network Interface – TP/FT-10 Channel (Model name: 75010R) (Required for each VRF Network)

Web monitoring tool

UTY-AMGXZ1

Features

- Troubleshooting is performed by monitoring each air conditioning unit remotely during a periodical system check.
- An error notification is automatically transmitted to several locations via the internet*1.
- Requires either a dedicated internet connection or landline to operate.
- The occurrence of an error can be confirmed through an error alert and equipment status information obtained from a remote location.
- Monitoring data can be downloaded in a remote location. These data can be accessed and displayed even when the service tool is in offline mode.
- Can be viewed on the monitoring computer's Web browser without installing any special software.

*1: Internet e-mail access required.

Web Monitoring System

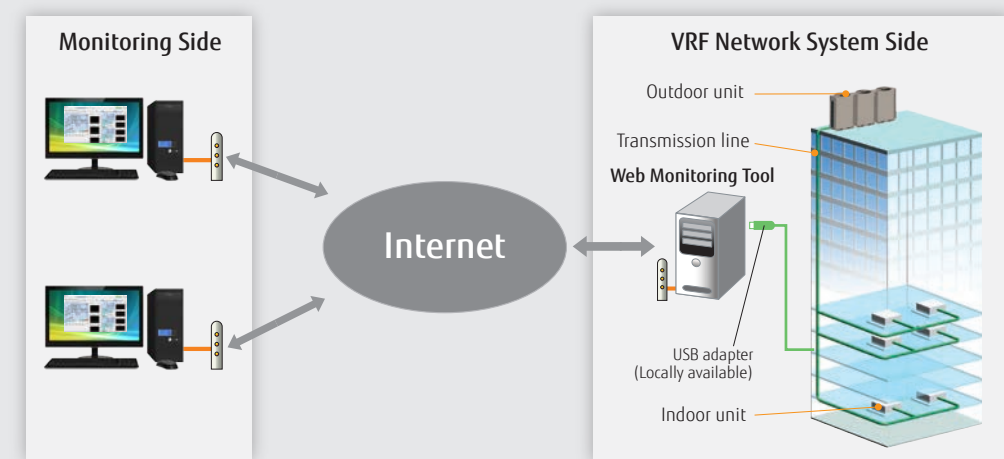

Supporting up to 4 VRF network systems

Up to 4 USB adapters can be connected to a computer, enabling the monitoring of up to 1,600 indoor units.

Suitable for use in a large building or hotel.

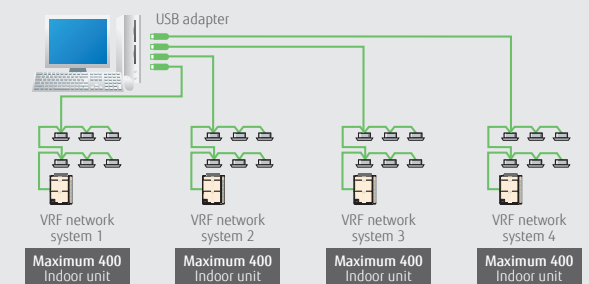

Computer requirements

UTY-AMGXZ1	
Operating system	• Microsoft® Windows® 7 Professional (32-bit or 64-bit) SP1 • Microsoft® Windows® 8.1 Pro (32-bit or 64-bit) • Microsoft® Windows® 10 Pro (32-bit or 64-bit)
CPU	1 GHz or higher
Memory	• 1 GB or more (for Windows® 7 [32-bit], Windows® 8.1 [32-bit], and Windows® 10 [32-bit]) • 2 GB or more (for Windows® 7 [64-bit], Windows® 8.1 [64-bit], and Windows® 10 [64-bit])
HDD	40 GB or more of free space
Screen resolution	1366 × 768 pixels or higher
Interface	• USB ports (one for U10 USB Network interface and up to 4 ports for software protection keys) • Interface for remote connection: - Landline: Modem is required. - Internet using LAN: Ethernet port is required.
Software	Internet Explorer® 11 or Microsoft Edge

Packing list

Name	Quantity	Application
White-USB-key (Software protection key)	1	Software protection key to be connected to a USB port on a Service tool-installed computer. This software runs only on a computer with WibuKey.

- Computer requirements
- Echelon® U10 USB Network Interface – TP/FT-10 Channel (Model name: 75010R) (Required for each VRF Network)